

SLOFEC TANK FLOOR INSPECTION REPORT

Client: Client
Facility: site
Items Inspected: Tank123
Inspection Method: SLOFEC
Commencement Date: 03rd May 2016
Completion Date: 06th May 2016
Type of Report: Final Report
Report Number: K0xx-16
Job Number: Jxx86



Unit 1, Howemoss Avenue
Kirkhill Industrial Estate, Dyce
Aberdeen, AB21 0GP
United Kingdom
Tel : +44 (0)1224-724744
Fax : +44 (0)1224-774087

Unit 27
Webb Ellis Industrial Park
Rugby, CV21 NP
United Kingdom
Tel : +44 (0)1788-547294
Fax : +44 (0)1788-547299



Client a	SLOFEC Tank Floor inspection	Page 1 of 12
Tank 123	Final	K0xx-16



SLOFEC™ TANK INSPECTION REPORT

(FS300)

Client a	SLOFEC Tank Floor inspection	Page 2 of 12
Tank 123	Final	K0xx-16



Executive Summary

Innospection Ltd was requested by Client to perform a SLOFEC™ (Saturation Low Frequency Eddy Current) inspection on Tank 123 from the 03rd to 06th May 2016.

This inspection report documents in detail the specific inspections that /have been conducted; the individual techniques and equipment utilised, and the results obtained.

The SLOFEC™ inspection indicated only a few areas of localised underside corrosion sporadically spread throughout the tank. However the greatest damage occurring was noted on the topside, where significant pits have developed and propagated due to the failure and degradation of the coal tar epoxy. Notably two plates (B24 & B45) had clear through wall pits that have propagated from the tops side.

Summary of inspection finding

Total number of plates : 61
Total number of plates inspected : 61
Number of damaged plates : 51

Number of plates identified with main indications on underside of tank floor

Below 20% wall loss : 28 plates
20% - 30% wall loss : 14 plates
31% - 40% wall loss : 7 plates
41% - 50% wall loss : 4 plates
Above 50%wall loss : 5 plates

Number of plates identified with main indications on topside of tank floor

Below 20% wall loss : 13 plates
20% - 30% wall loss : 4 plates
31% - 40% wall loss : 5 plates
41% - 50% wall loss : 13 plates
Above 50%wall loss : 26 plates

Client a	SLOFEC Tank Floor inspection	Page 3 of 12
Tank 123	Final	K0xx-16



Table of Contents

1.	Test Object Data	5
2.	Inspection Task	5
3.	Inspection Personnel.....	5
4.	Inspection Volume.....	6
5.	Inspection Equipment.....	6
5.1.	SLOFEC™ Equipment	6
5.2.	Ultrasonic Equipment.....	7
6.	SLOFEC™ Equipment Setting.....	7
7.	SLOFEC™ Equipment Calibration.....	8
7.1.	Equipment Calibration.....	8
7.2.	Calibration Control	8
7.3.	Calibration Samples.....	8
7.4.	Change of Settings	9
8.	Inspection Procedures.....	9
9.	Inspection Performance	9
9.1.	Scanner Movement.....	9
9.2.	Scan Track Positioning	9
9.3.	Parameter Storage	9
10.	Defect Analysis	9
11.	Comments to Inspection.....	10
12.	Result Overview	10
12.1.	Sensitivity Settings.....	10
12.2.	Result Overview.....	11
13.	Inspection Summary.....	12
14.	Documentation	12
15.	Signature.....	12

Client a	SLOFEC Tank Floor inspection	Page 4 of 12
Tank 123	Final	K0xx-16



Appendix 1 : Underside Condition Report

- Scan Defect Map
- Individual Plate Scan Report

Appendix 2 : Topside Condition Report

- Scan Defect Map
- Individual Plate Scan Report

Appendix 3: Ultrasonic thickness Report

- Combined Underside & UT thickness Tank Report
- Individual Plate wall thickness Measurements

Client a	SLOFEC Tank Floor inspection	Page 5 of 12
Tank 123	Final	K0xx-16



1. Test Object Data

Object Identification : Tank 123

Location of Object : Client a

Wall Thickness : Floor Plates 8.0mm
Annular Plates: 9.6mm

Material : Carbon Steel

Surface Condition : Coal tar epoxy (400 microns)

2. Inspection Task

As requested by Client a SLOFEC™ (Saturation Low Frequency Eddy Current) inspection was performed on Tank 123 located at site b between the 03rd & 06th May 2016.

The inspection was performed with a SLOFEC™ technology scanner, type FS300.

SLOFEC™ is regarded as a fast corrosion screening technique for the detection of corrosion on either side of the inspected tank floor and under the coatings.

The SLOFEC™ inspection team consisted of qualified engineers from Innospection Ltd.

All areas described in Section 4 – Inspection Volume were inspected with the SLOFEC™ scanner.

The inspection was carried out due to through wall perforations noted in the tank floor during a repair of the roof and annular plates of the tank.

3. Inspection Personnel

Inspection Supervisor : Technician a
Certification / Certificate No. 000000

SLOFEC Operator : Technician b
Certification / Certificate No. b

SLOFEC Assistant Assistant a

Client a	SLOFEC Tank Floor inspection	Page 6 of 12
Tank 123	Final	K0xx-16



4. Inspection Volume

All accessible areas on the bottom of the tank-floor including the annular ring were targeted for inspection.

The dead zones for each plate differed depending on the number of obstructions and shape of the plates encountered. Typically the dead zones for a clear plate with 90 deg corners had a dead zone of approximately 200 x 200 mm in each plate corner. Spot Ultrasonic thickness gauging was carried out in these dead areas depending of the surface condition on the floor plate in that location.

In the attached scan reports, the scanner areas are displayed with its coloured condition images.

5. Inspection Equipment

5.1. SLOFEC™ Equipment

The inspection system consisted of the following SLOFEC™ equipment and accessories:

Scanner : SLOFEC™ FS300 Scanner (width 300mm)

Description of Scanner : The SLOFEC™ FS300 Scanner is a motorised scanner system consisting of a permanent magnet for magnetisation and multiplexed electronics. Eight (8) sensors each with a width of 35mm are located between the pole-shoes. A trigger encoder is utilised

Scanning Speed : 50% (approx. 24m/min)

Eddy Current Instrument : IBM-AT-compatible computer with 2-frequency Eddy current plug-in cards
Type : Beltronic Serial No. 10

Eddy Current Sensors : 8 x EC-B-35 mm

Software Version : Slofec™ V5 Software

Cable : 60 metres of specific cable connection, divided in 2 x 30m

Reference Plate : 8mmm and 10mm(Innospection stock),

Reference Defect : 20%, 40%, 60%, 80% FBH

Client a	SLOFEC Tank Floor inspection	Page 7 of 12
Tank 123	Final	K0xx-16



5.2. Ultrasonic Equipment

The Ultrasonic equipment consisted of the following accessories:

USMGO Ultrasonic Unit
Serial No. 90110981

Capable of both “A” scan display and digital thickness readout
5 MHz 10mm Ø twin crystal transducer
2mm – 12mm carbon steel calibration step wedge

6. SLOFEC™ Equipment Setting

In general, the SLOFEC™ system is calibrated using sample test samples with artificial reference defects. The reference samples should be of the same material and thickness as the surface to be inspected.

In the case of a coating being present on the surface to be inspected, the average thickness of the coating (if applicable) should also be simulated on the reference sample for the calibration.

Typical reference defects that are used are flat bottom holes or conical bottom holes having a diameter of 5mm, 10mm and 20mm.

The depths of the artificial reference defects are typically 20%, 40%, 60%, 80% and 100%.

For calibration, the SLOFEC™ system is driven over the reference defects and the channels are set (one sensor per channel) to give a sufficient sensitivity level for the detection of underside and topside corrosion defects.

The calibration is performed at the beginning, after breaks, at the end of every shift and when significant changes are made to the settings of the equipment.

The calibration results and reference defect data from the calibration sample is always stored in the system.

The Eddy Current signal analysis is done online. The computerised equipment and the software allow the analysis of the signal amplitude [in div.] and signal phase [in °].

In discussion with the individual client, indications comparable with the reference defect indications can be marked on the floor and are usually recommended to be re-inspected by Ultrasonic (UT) examination.

Client a	SLOFEC Tank Floor inspection	Page 8 of 12
Tank 123	Final	K0xx-16

7. SLOFEC™ Equipment Calibration

7.1. Equipment Calibration

For internal corrosion detection, the differential mode was used. Optimum signal / noise ratio and signal phase separation between the internal defect indications and other indications were considered when selecting a suitable test frequency.

The differential channels of all the sensors were set so that internal defects were indicated in the vertical signal phase direction as shown in the diagram below. By moving the scanner in the positive forward direction, the internal defect signal would show the first peak down, followed by the second peak up with an upward movement.

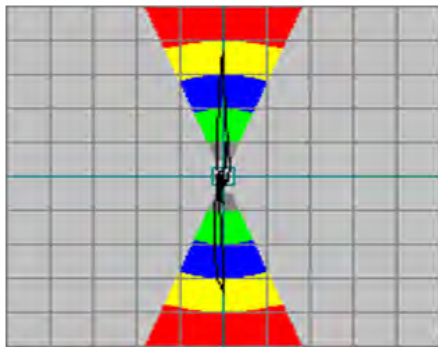

Sample signal display of internal defect

7.2. Calibration Control

The general setting and calibration was performed at the beginning of the inspection and all the calibration data was stored digitally. Calibration controls were performed at the beginning and end of each working shift as well as after any other significant interruption (i.e. breaks or lunch). Re-calibration is also deemed necessary when significant changes are made to the settings of the equipment.

Calibration samples are used for the initial set-up and for the random check of operator's settings.

Full and accurate sensitivity settings are achieved only when the first indication found on the object undergoing the test is verified by an UT operator with the corresponding depth of indication and SLOFEC™ sensitivity being adjusted accordingly.

7.3. Calibration Samples

The calibration samples are manufactured by Innospection Ltd in accordance to the setting standard requirements.

Client a	SLOFEC Tank Floor inspection	Page 9 of 12
Tank 123	Final	K0xx-16



7.4. **Change of Settings**

In the event of any scanner adjustment, re-calibration is performed.

8. **Inspection Procedures**

The inspection was performed according to the following valid procedure:

SLOFEC™ Tank Procedure No. InnoTSloTNK-001-08 – Current Issue

9. **Inspection Performance**

9.1. **Scanner Movement**

The scanner assistant, who was in permanent communication with the SLOFEC™ operator, was responsible for positioning and moving the scanner on the pipe surface. The SLOFEC™ FS300 Scanner is marked clearly on the top with the FORWARD and BACKWARD directions so that all scan directions are made clear to the operator and assistant at all times. In addition, some visual contact between the operator and assistant was established during the inspection.

The scanner was moved manually with the scanned tracks being overlapped at all times. All scans for the inspection were recorded in the forward position.

9.2. **Scan Track Positioning**

Between the SLOFEC™ engineers, a clear description of the track position was established.

9.3. **Parameter Storage**

The Eddy Current testing parameter was set during the calibration and digitally stored according to the scan direction and lift off.

10. **Defect Analysis**

All indications which showed a clear signal phase direction similar to that of the reference defects and had signal amplitude equivalent to that of the test piece were subjected to analysis.

Signals that are clearly out of the corrosion phase direction were not reported.

Client a	SLOFEC Tank Floor inspection	Page 10 of 12
Tank 123	Final	K0xx-16



11. Comments to Inspection

The Tank was found in a general clean condition having been cleaned prior to the survey. The floor had been coated in a coal tar epoxy and it was noted that significant topside pitting was occurring in areas where the epoxy had failed.

12. Result Overview

12.1. Sensitivity Settings

The general overview of the inspected areas with the results is presented in the attached colour scan reports with wall loss being represented in colour classes as shown in the Wall Loss Legend below:

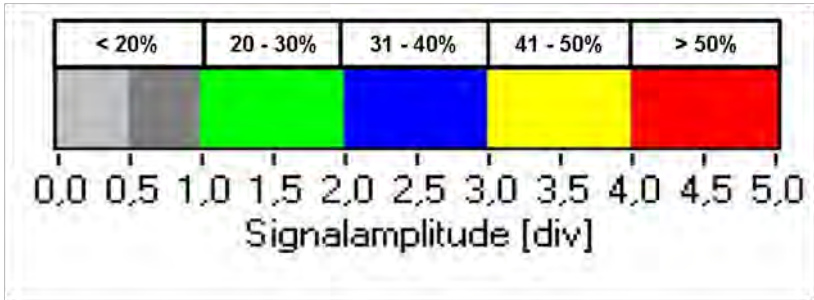

- Below 20% wall loss - Grey
- 20-30% wall loss - Green
- 31-40% wall loss - Blue
- 41-50% wall loss - Yellow
- Above 50% wall loss - Red

Note

Eddy Current inspection is an evaluation method of NDT; hence all results obtained are based upon the test piece used. Material and wall thickness of the test piece should be as near as reasonably practicable to the item under inspection. Artificial defects should be as near in size and shape as to the type sought.

Because SLOFEC™ signal amplitudes are an indication of defect depth and volume, the defect depth analysis by signal amplitude can only be done in comparison with artificial reference defects having varying depths.

Client a	SLOFEC Tank Floor inspection	Page 11 of 12
Tank 123	Final	K0xx-16



12.2. Result Overview

All SLOFEC™ scans are shown in Appendices 1 & 2. Ultrasonic wall thickness readings are shown in Appendix 3. A summary of the inspection findings in each of the scanned section is given below.

Summary of inspection finding

Total number of plates : 61
Total number of plates inspected : 61
Number of damaged plates : 51

Number of plates identified with main indications on underside of tank floor

Below 20% wall loss : 28 plates
20% - 30% wall loss : 14 plates
31% - 40% wall loss : 7 plates
41% - 50% wall loss : 4 plates
Above 50%wall loss : 5 plates

Number of plates identified with main indications on topside of tank floor

Below 20% wall loss : 13 plates
20% - 30% wall loss : 4 plates
31% - 40% wall loss : 5 plates
41% - 50% wall loss : 13 plates
Above 50%wall loss : 26 plates

Client a	SLOFEC Tank Floor inspection	Page 12 of 12
Tank 123	Final	K0xx-16



13. Inspection Summary

The SLOFEC™ inspection indicated only a few areas of localised underside corrosion sporadically spread throughout the tank. However the greatest damage occurring was noted on the top side where significant pits have developed and propagated due to the failure and degradation of the coal tar epoxy. Notably two plates (B24 & B45) had clear through wall pits that have propagated from the tops side.

14. Documentation

The inspection result, parameters and data are stored in the Innospection Limited archive database system.

15. Signature

Technician a
Lead Technician
Innospection Limited

Level 3
Senior Engineer
Innospection Limited



APPENDIX 01

Underside Condition Report

General Tank Floor Overview Individual Plate View

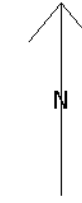

SLOFEC™

1 1

: Client a
 : site b
 : Tank123
 : 24.00 m
 : 452.39 qm
 : 8.00 mm
 : 9.60 mm
 : 0.00 mm
 : 0.00 mm
 : Jxx86
 : K0xx-16
 : 03/05/2016

Underside-Differential

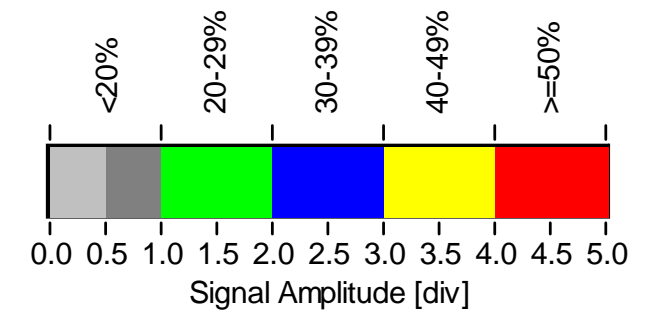
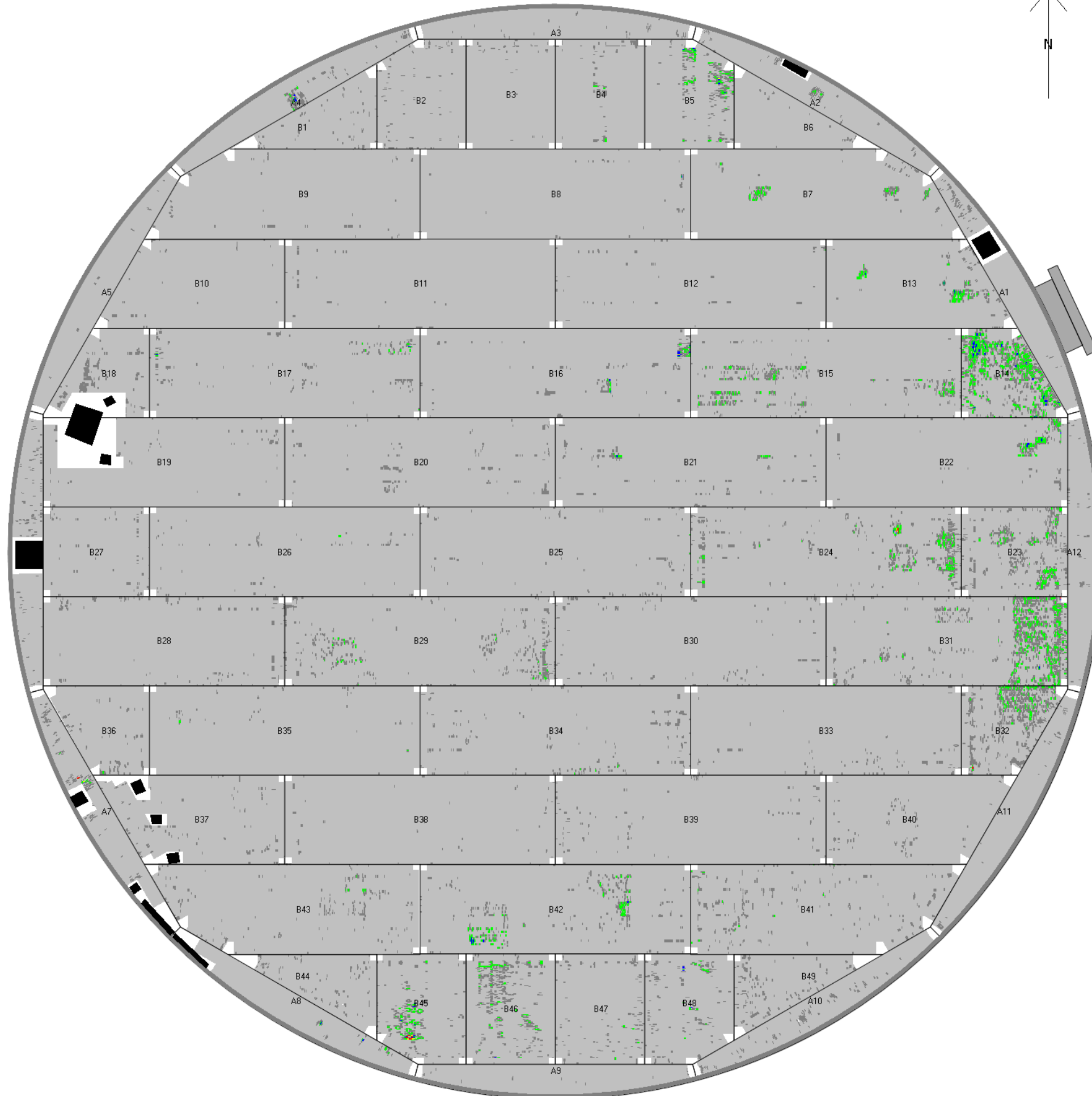

: Client a : Site a : 03/05/2016 : A 1	: Tank 123 : K0xx-16 : Jxx86
---	------------------------------------

Underside-Differential

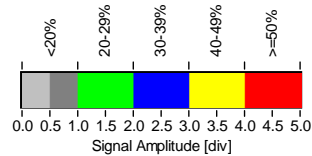
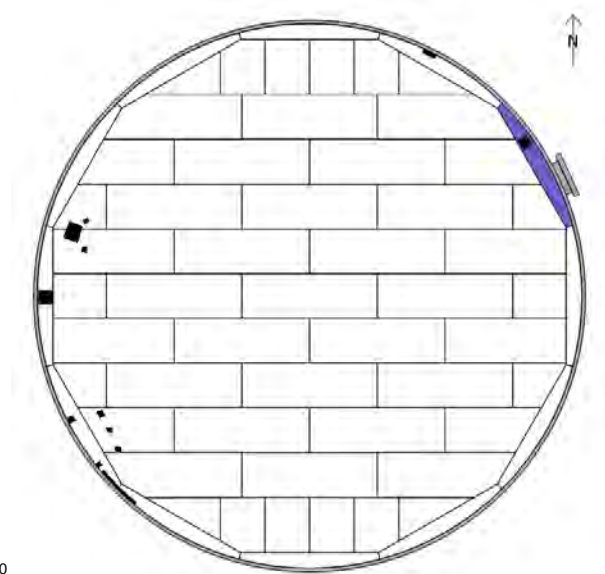
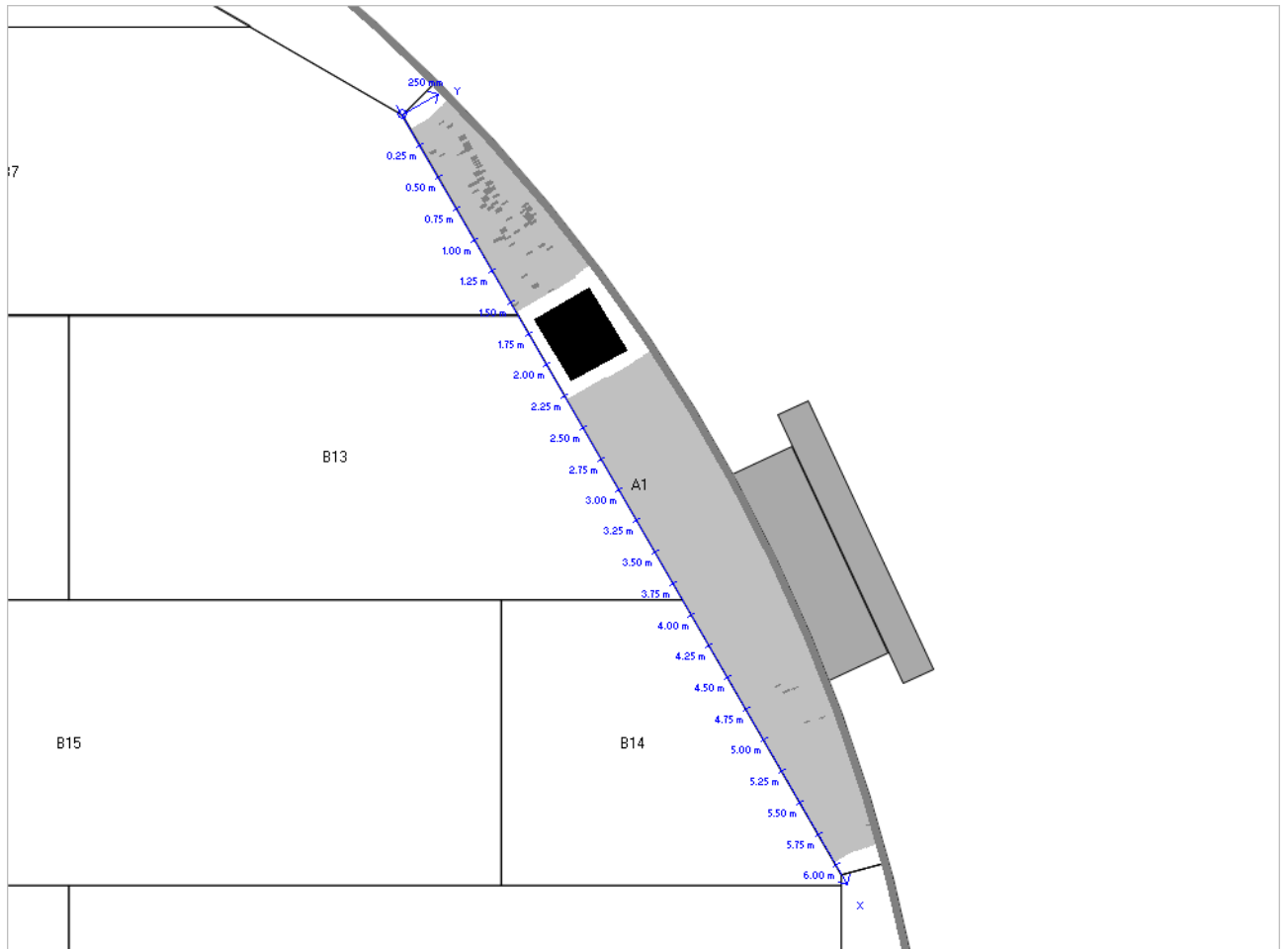

<ul style="list-style-type: none"> : Client a : Site b : 03/05/2016 : A 2 	<ul style="list-style-type: none"> : Tank 123 : K0xx-16 : Jxx86
---	--

Underside-Differential

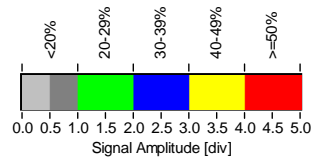
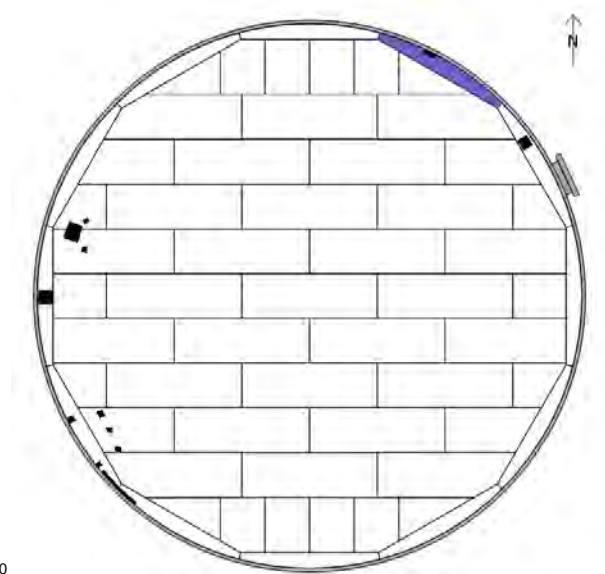
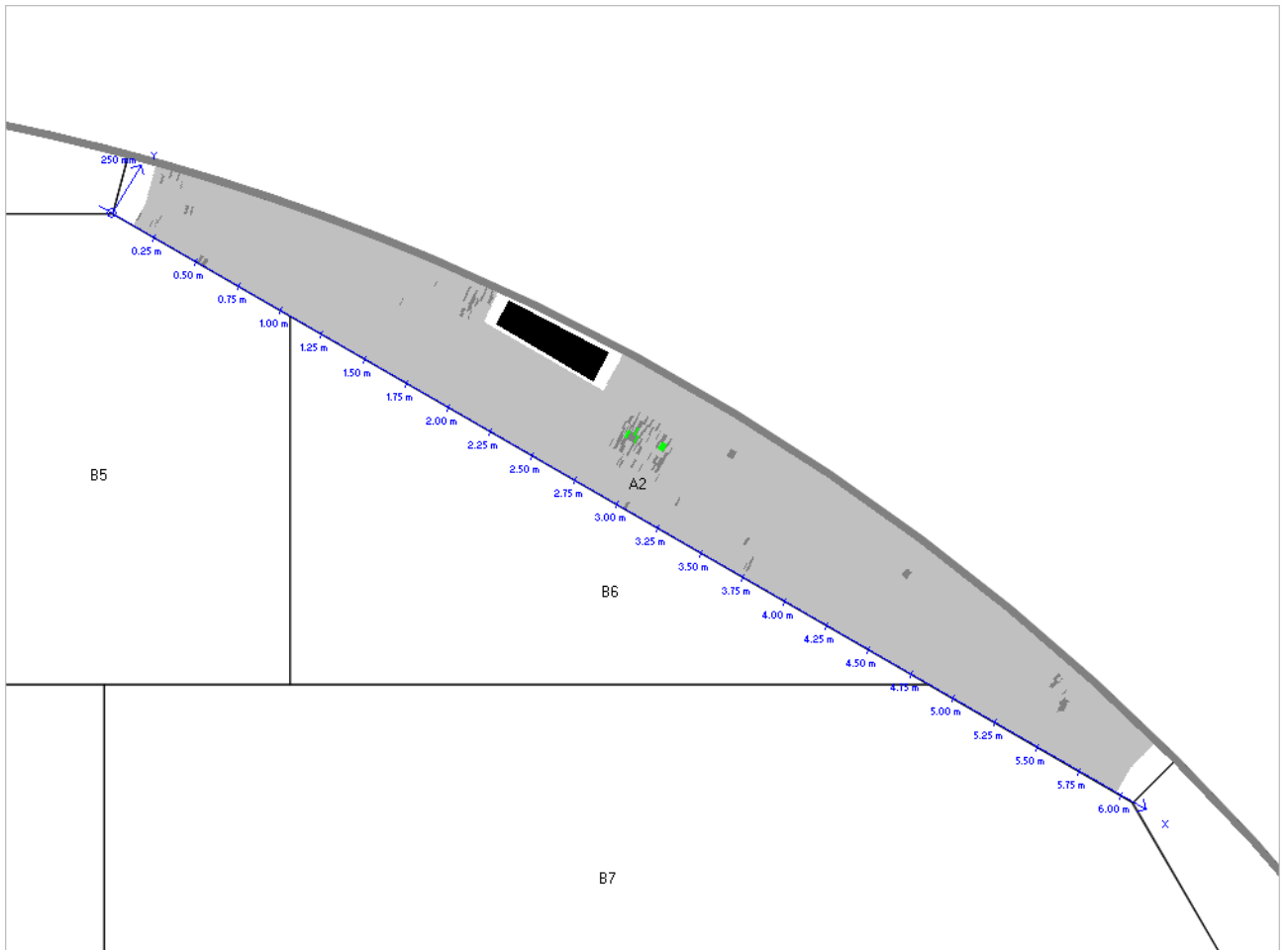

<ul style="list-style-type: none"> : Client a : Site b : 03/05/2016 : A 3 	<ul style="list-style-type: none"> : Tank 123 : K0xx-16 : Jxx86
---	--

Underside-Differential

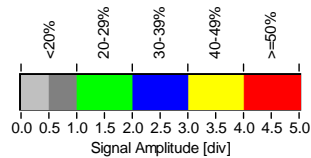
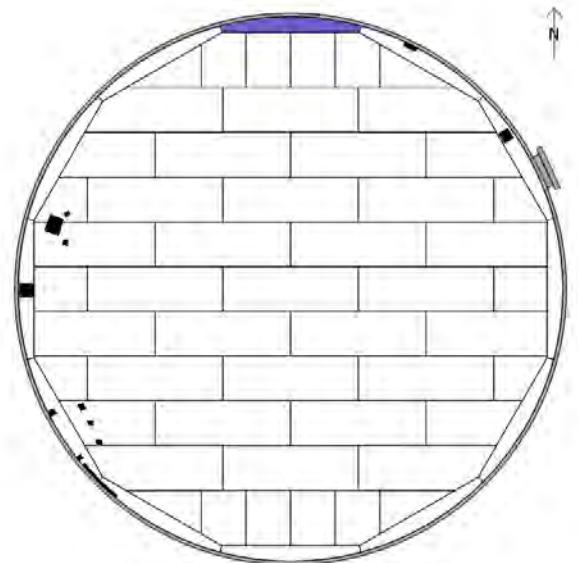
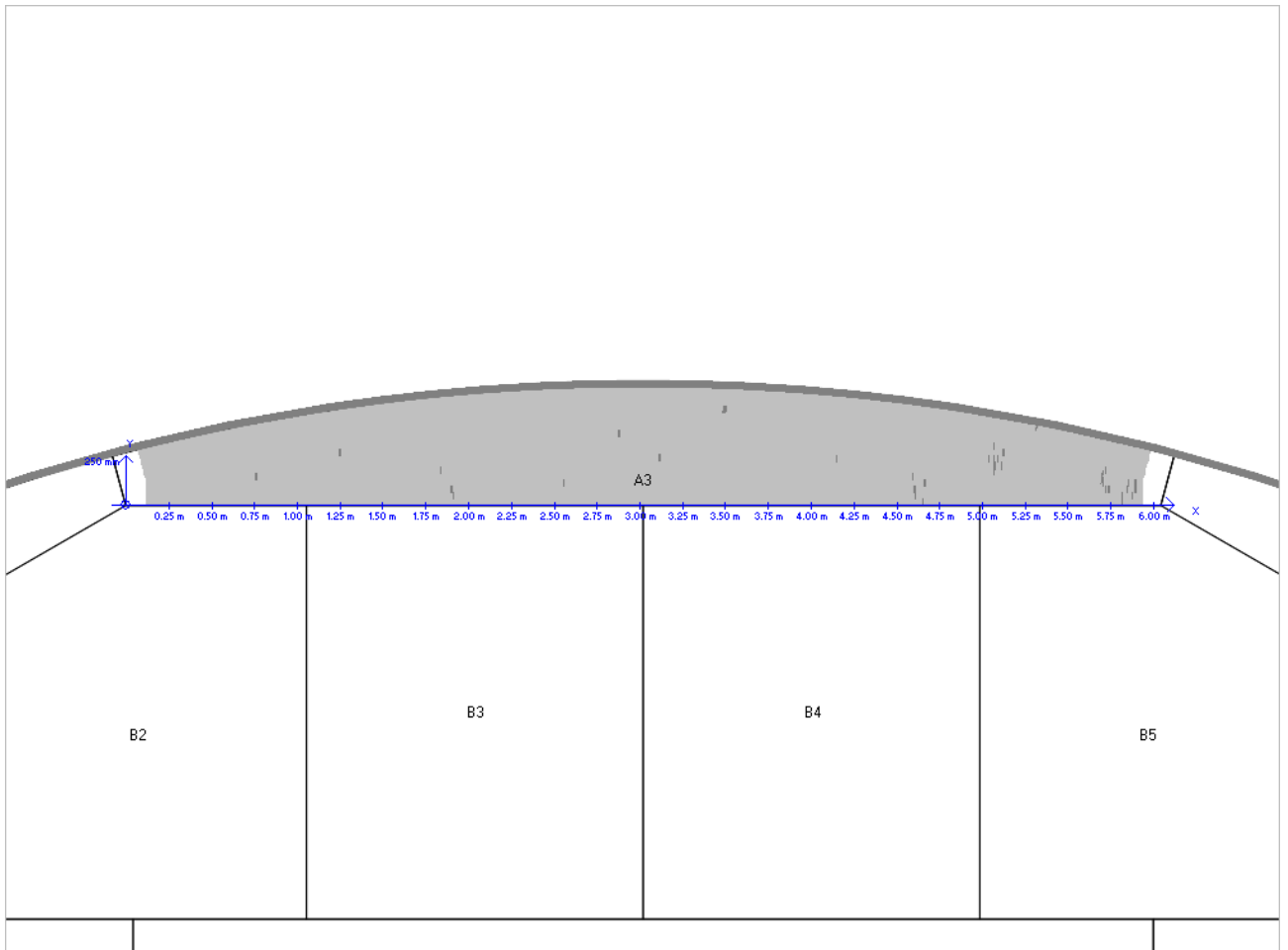

: Client a : Site a : 03/05/2016 : A 4	: Tank 123 : K0xx-16 : Jxx86
---	------------------------------------

Underside-Differential

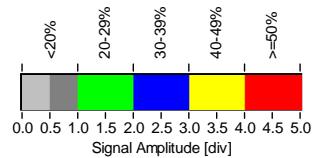
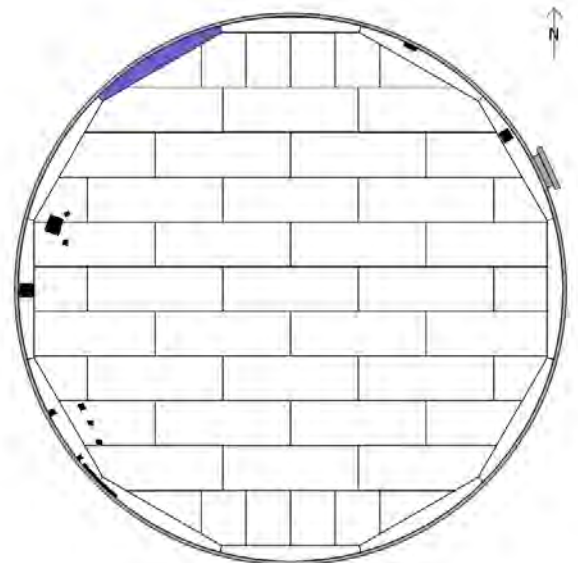
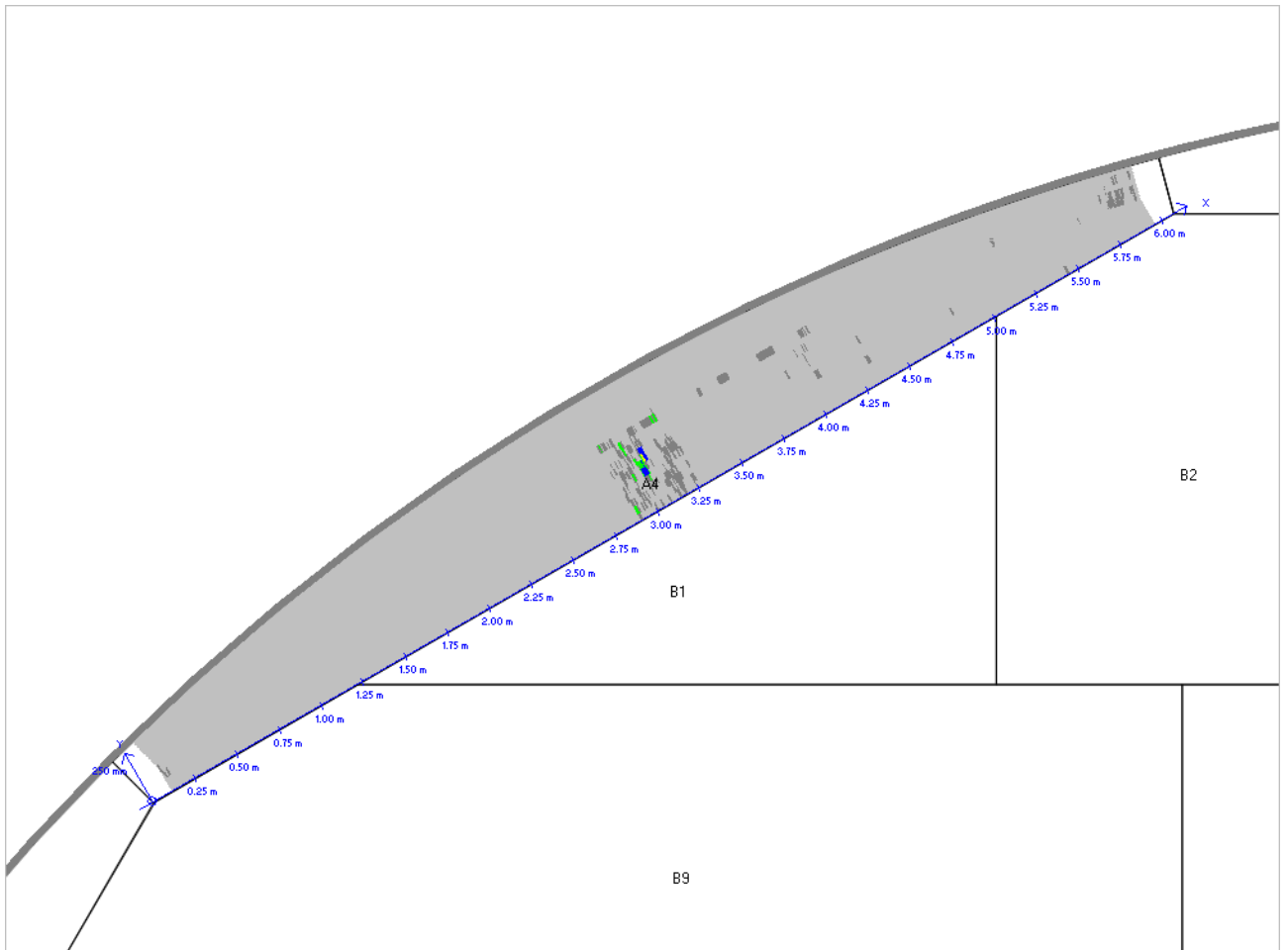

<ul style="list-style-type: none"> : Client a : Site b : 03/05/2016 : A 5 	<ul style="list-style-type: none"> : Tank 123 : K0xx-16 : Jxx86
---	--

Underside-Differential

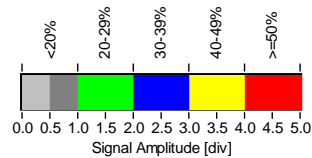
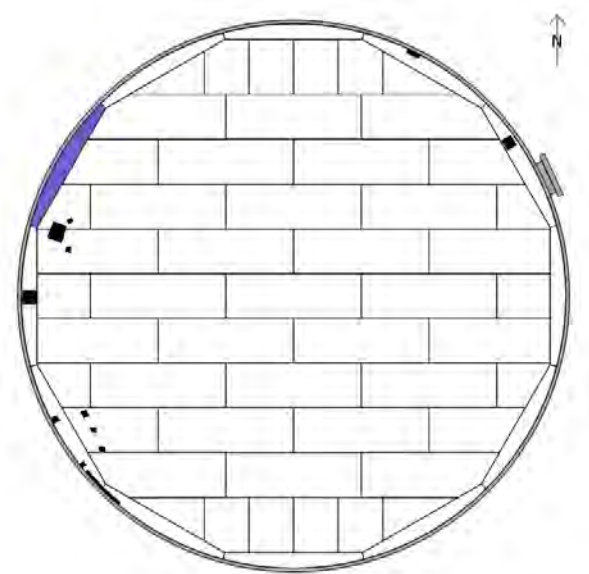
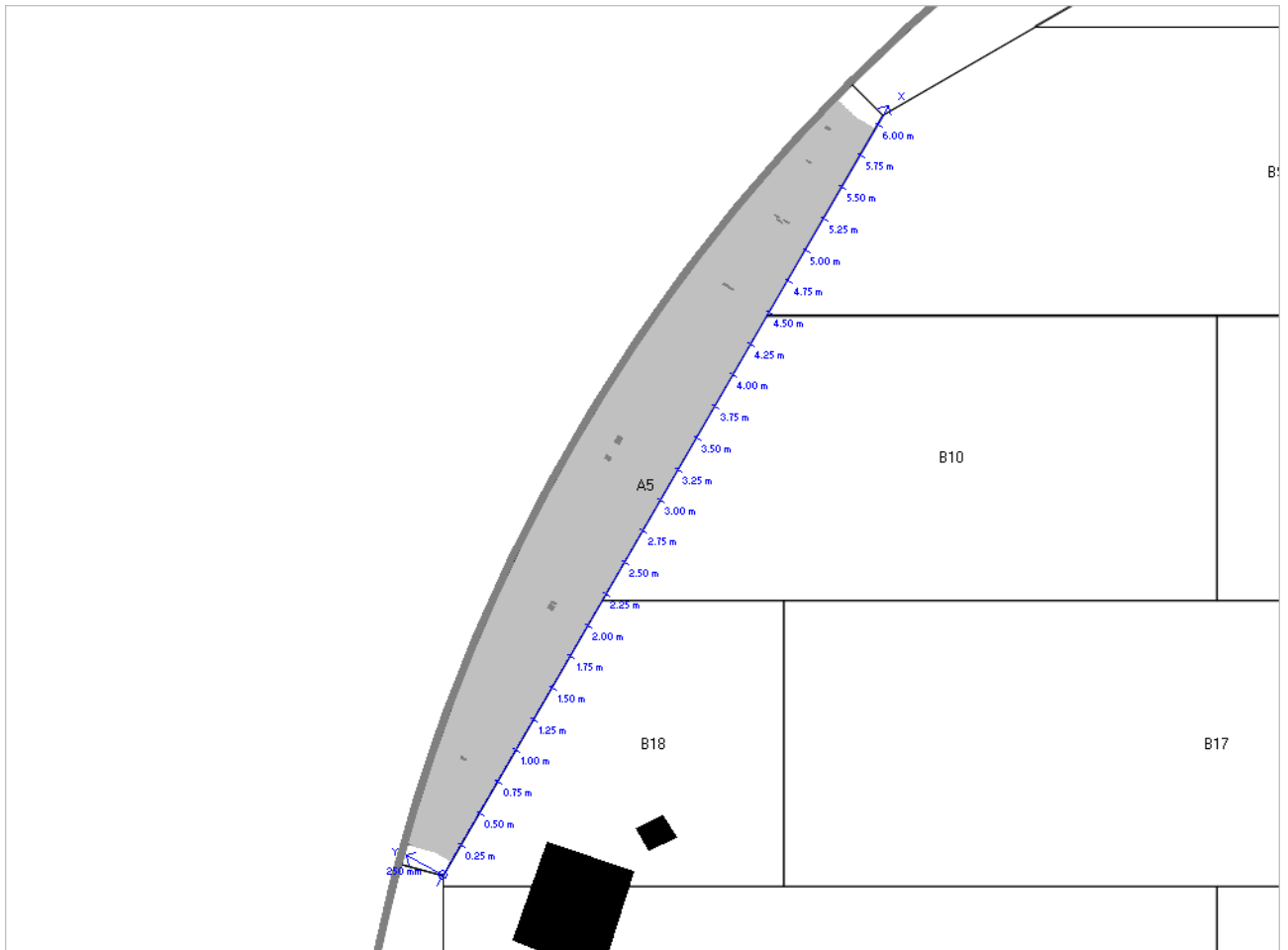

<ul style="list-style-type: none"> : Client a : Site b : 03/05/2016 : A 6 	<ul style="list-style-type: none"> : Tank 123 : K0xx-16 : Jxx86
---	--

Underside-Differential

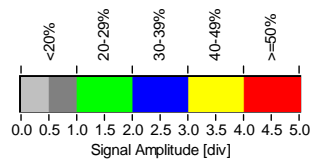
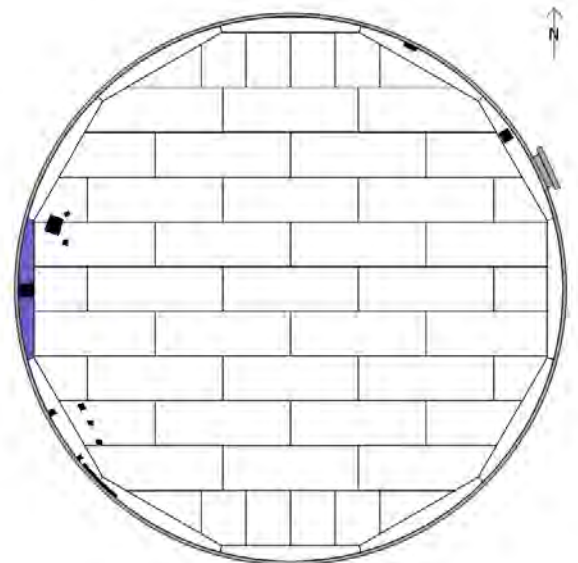
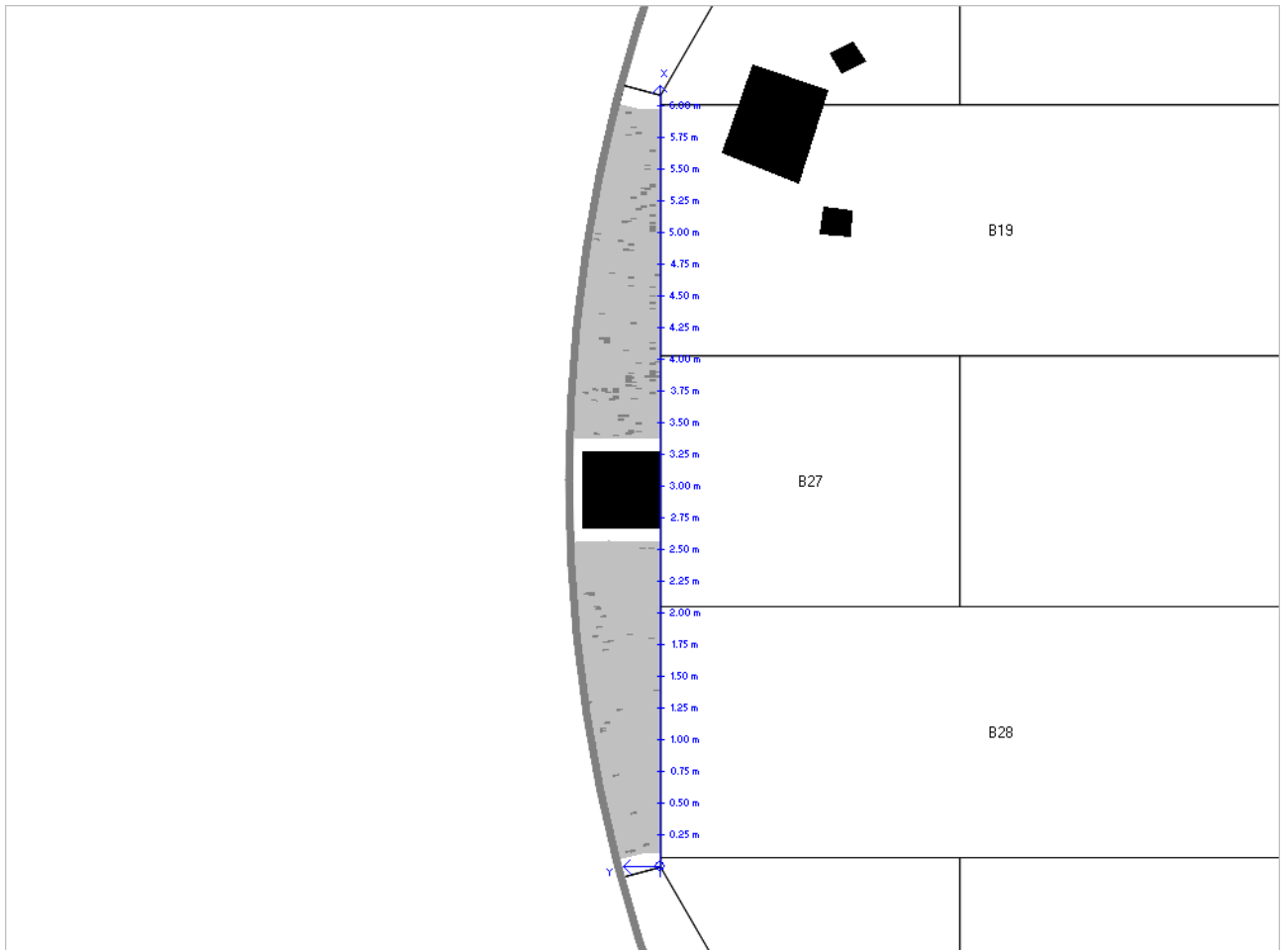

: Client a : Site b : 03/05/2016 : A 7	: Tank 123 : K0xx-16 : Jxx86
---	------------------------------------

Underside-Differential

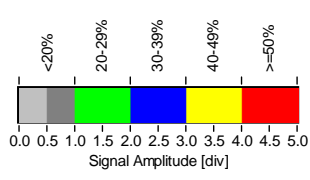
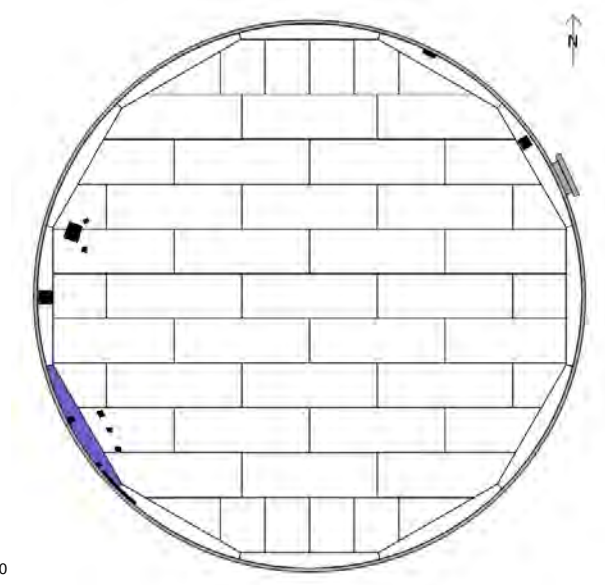
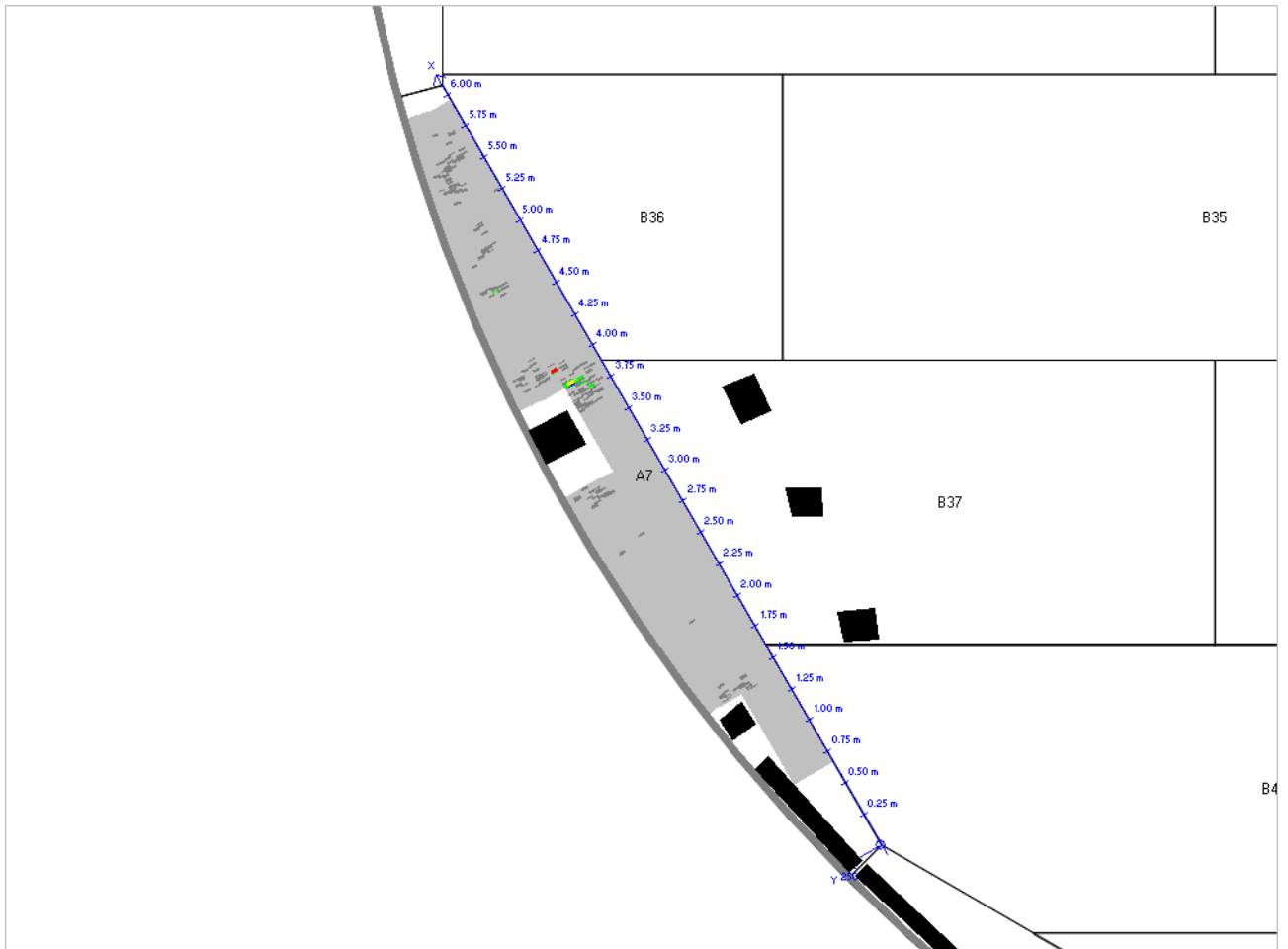

<ul style="list-style-type: none"> : Client a : Site b : 03/05/2016 : A 8 	<ul style="list-style-type: none"> : Tank b : K0xx-16 : Jxx86
---	--

Underside-Differential

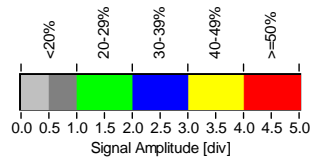
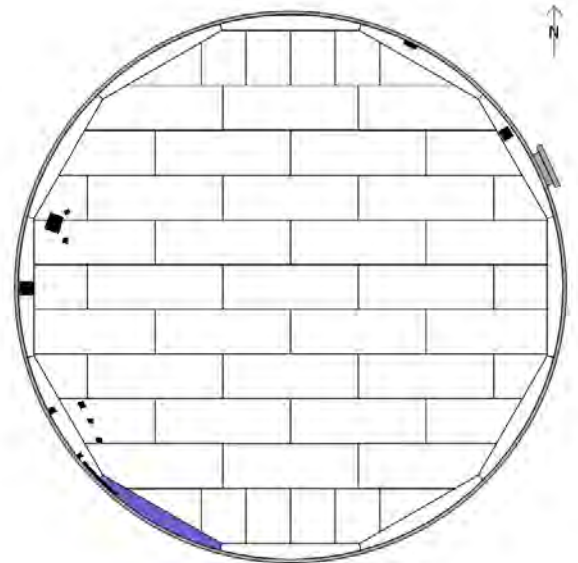
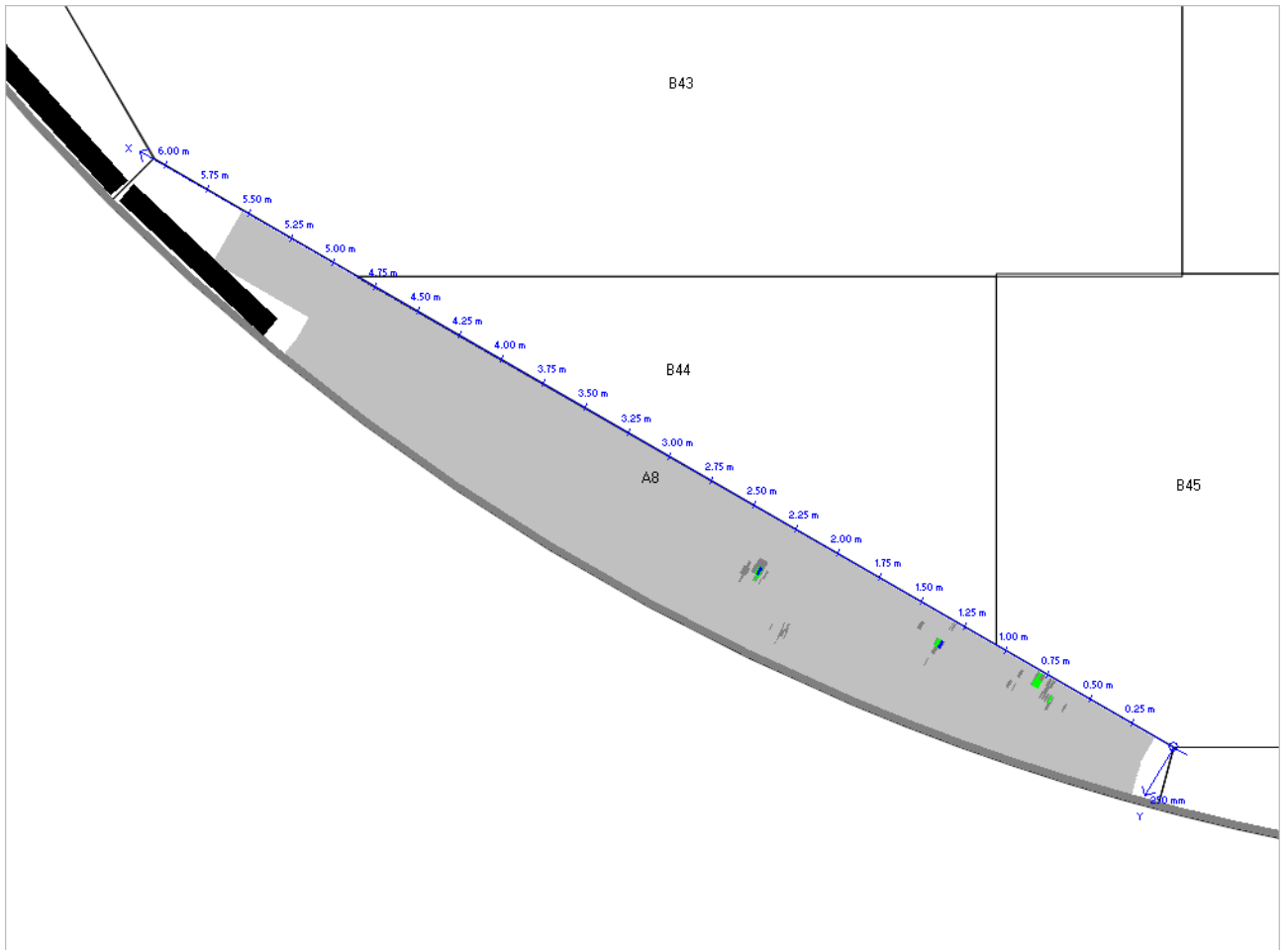

: Client a : Site b : 03/05/2016 : A 9	: Tank 123 : K0xx-16 : Jxx86
---	------------------------------------

Underside-Differential

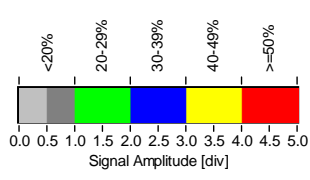
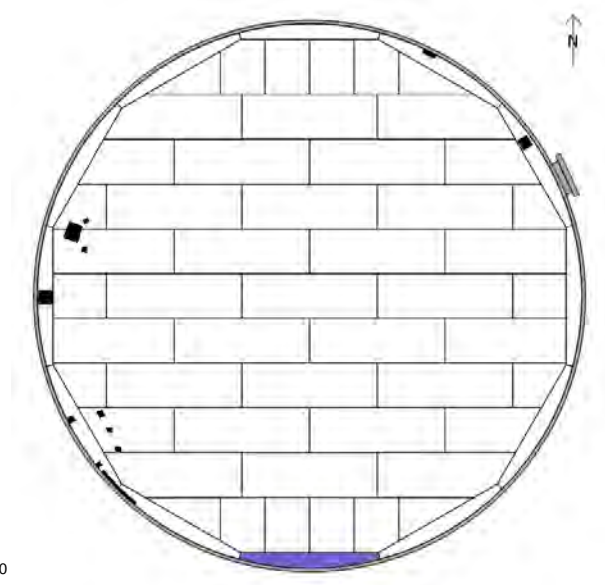
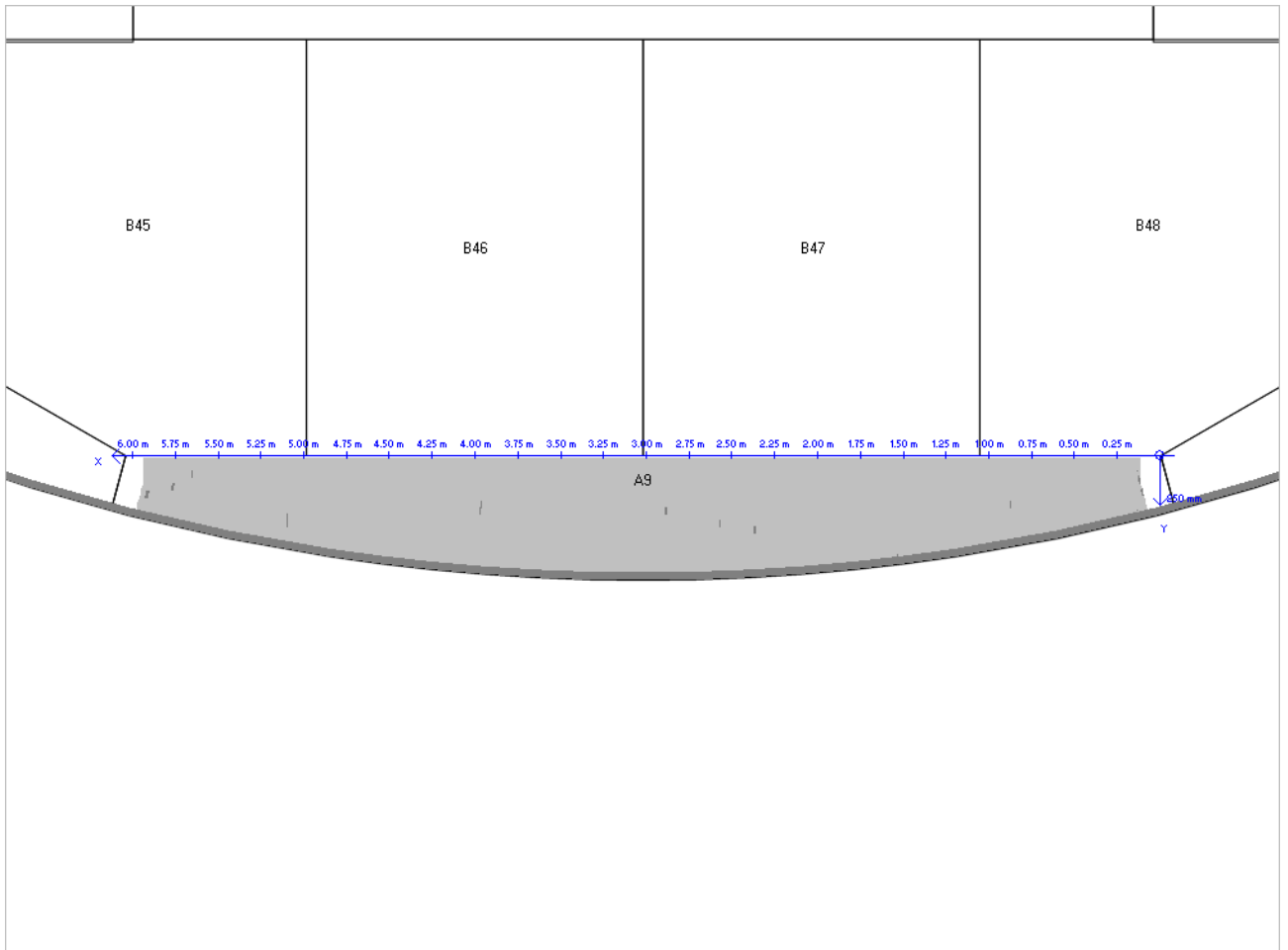

<ul style="list-style-type: none"> : Client a : Site a : 03/05/2016 : A 10 	<ul style="list-style-type: none"> : Tank 123 : K0xx-16 : Jxx86
--	--

Underside-Differential

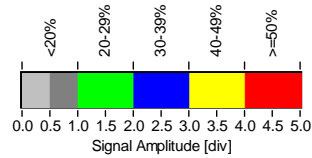
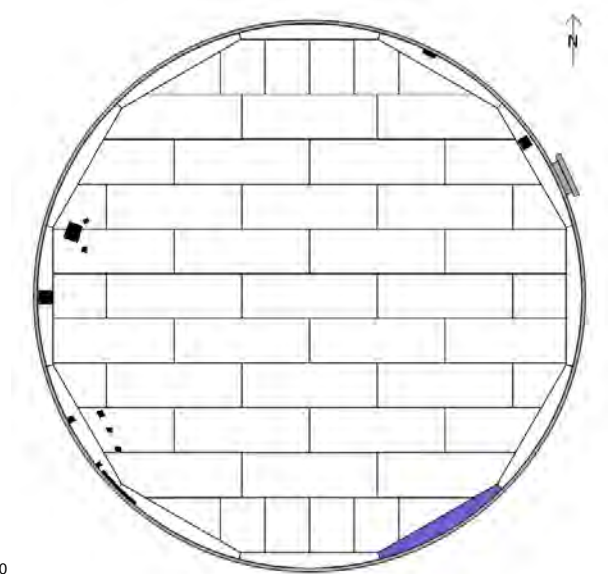
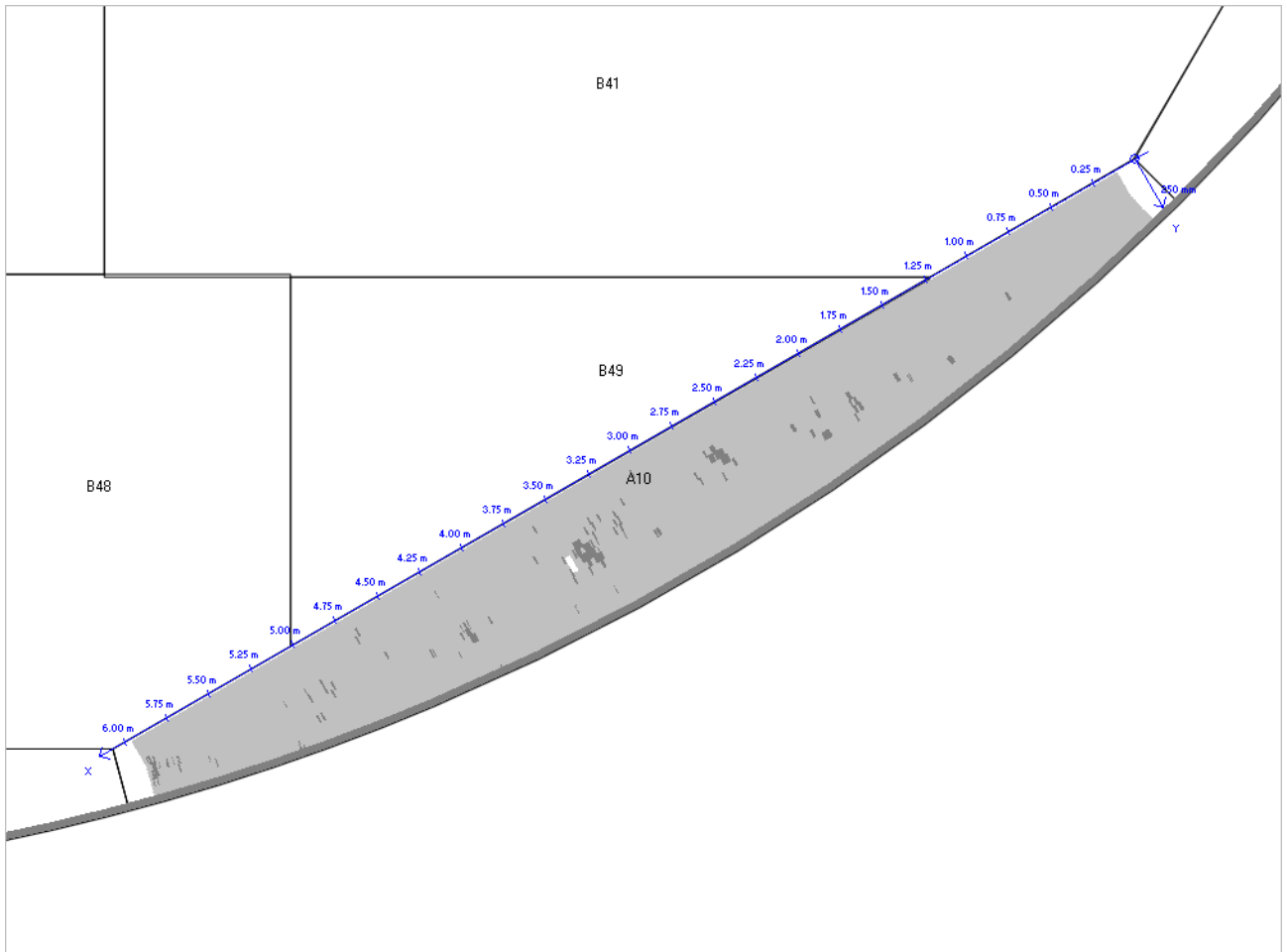

<ul style="list-style-type: none"> : Client a : Site b : 03/05/2016 : A 11 	<ul style="list-style-type: none"> : Tank 123 : K0xx-16 : Jxx86
--	--

Underside-Differential

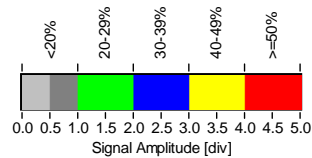
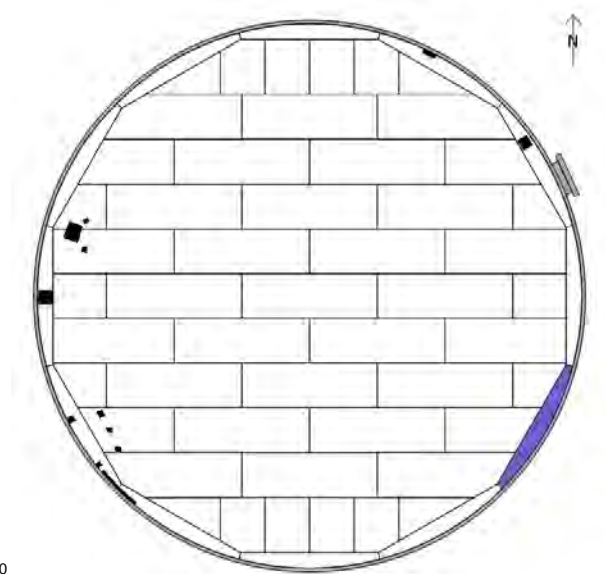
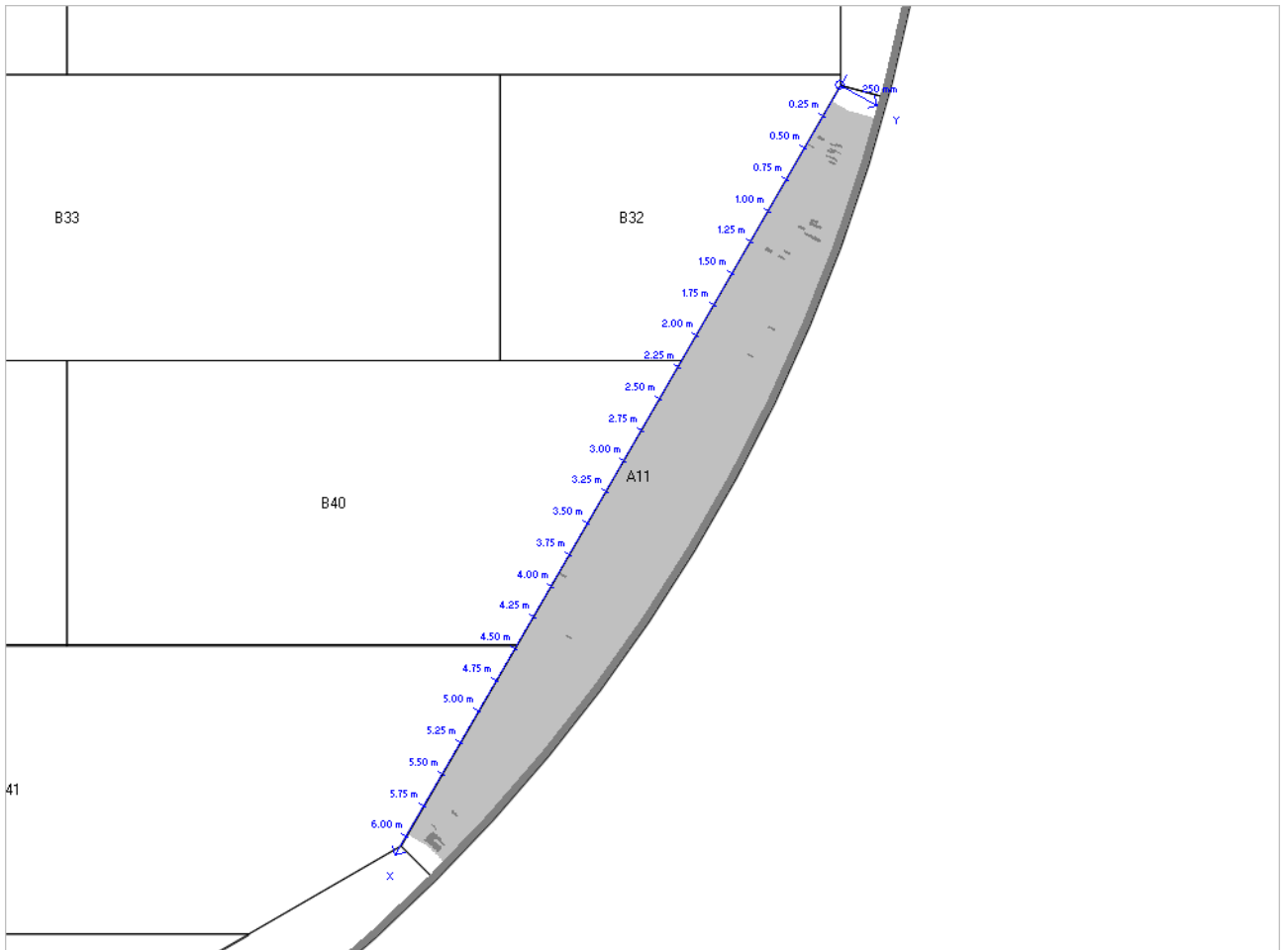

: Client a : Site b : 03/05/2016 : A 12	: Tank 123 : K0xx-16 : Jxx86
--	------------------------------------

Underside-Differential

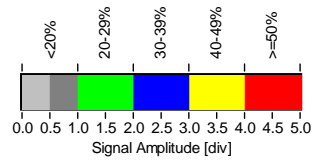
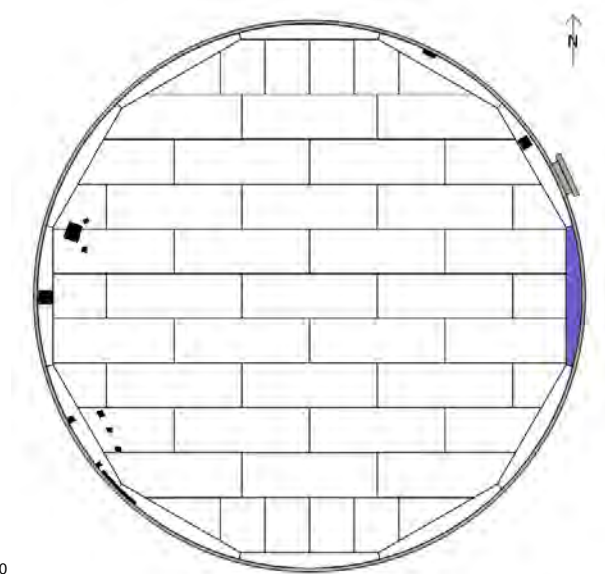
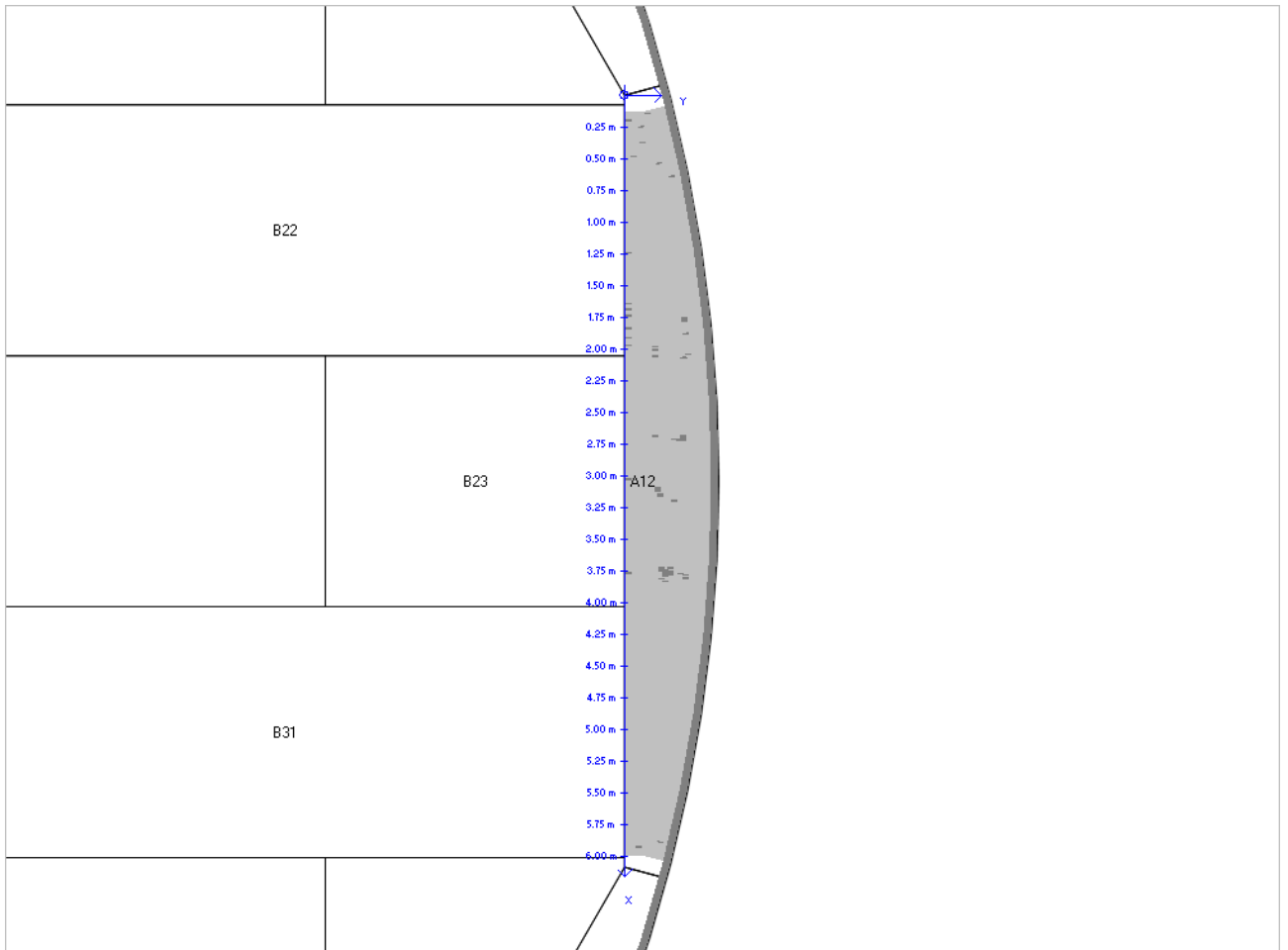

<ul style="list-style-type: none"> : Client a : Site b : 03/05/2016 : B 1 	<ul style="list-style-type: none"> : Tank 123 : K0xx-16 : Jxx86
---	--

Underside-Differential

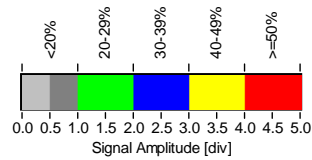
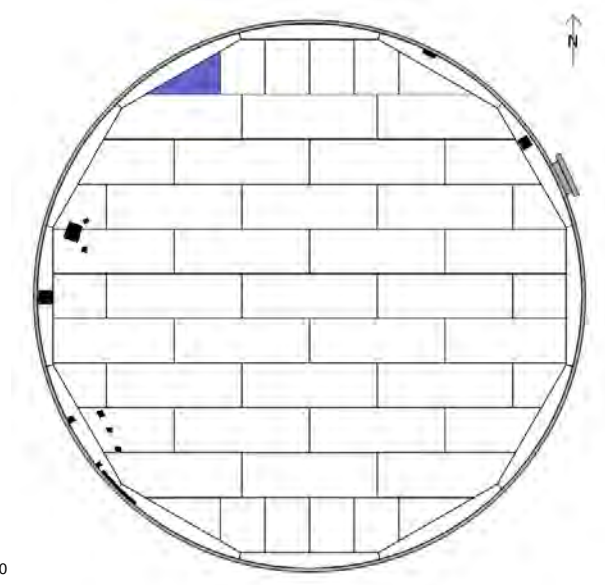
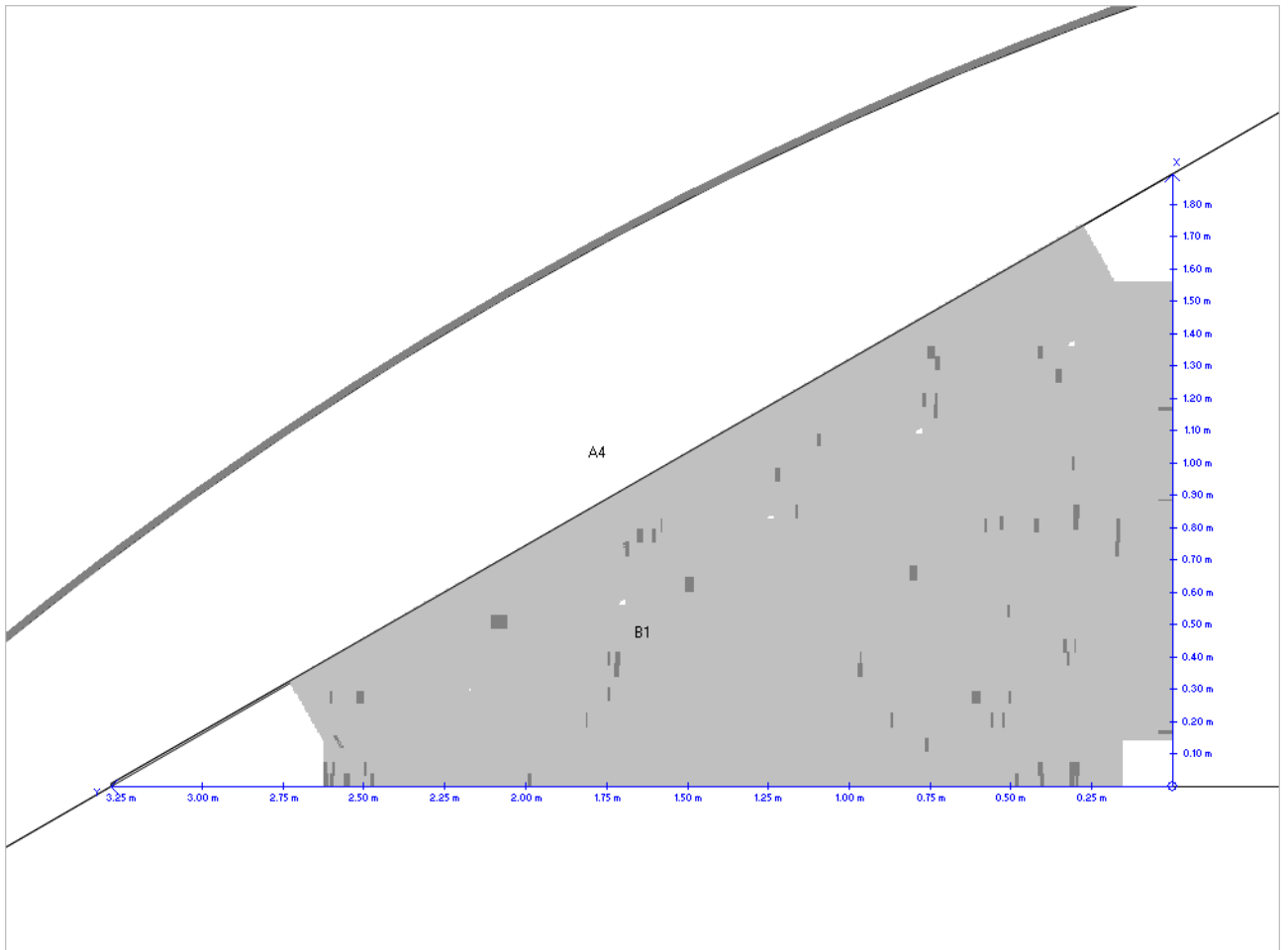

<ul style="list-style-type: none"> : Client a : Site b : 03/05/2016 : B 2 	<ul style="list-style-type: none"> : Tank 123 : K0xx-16 : Jxx86
---	--

Underside-Differential

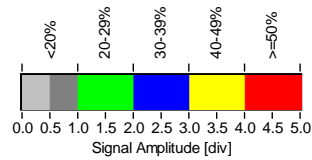
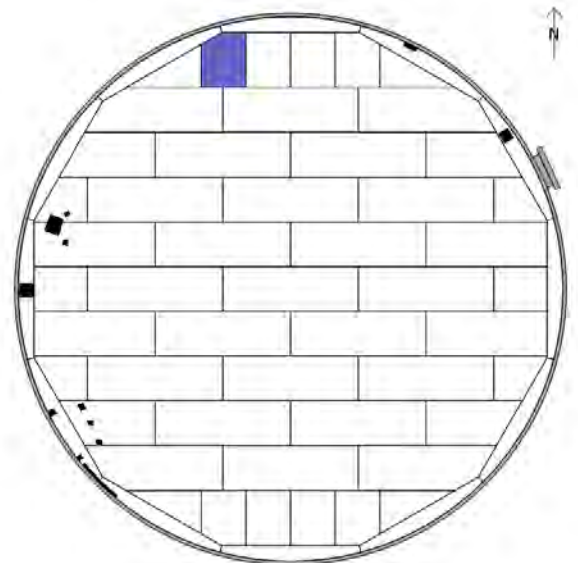
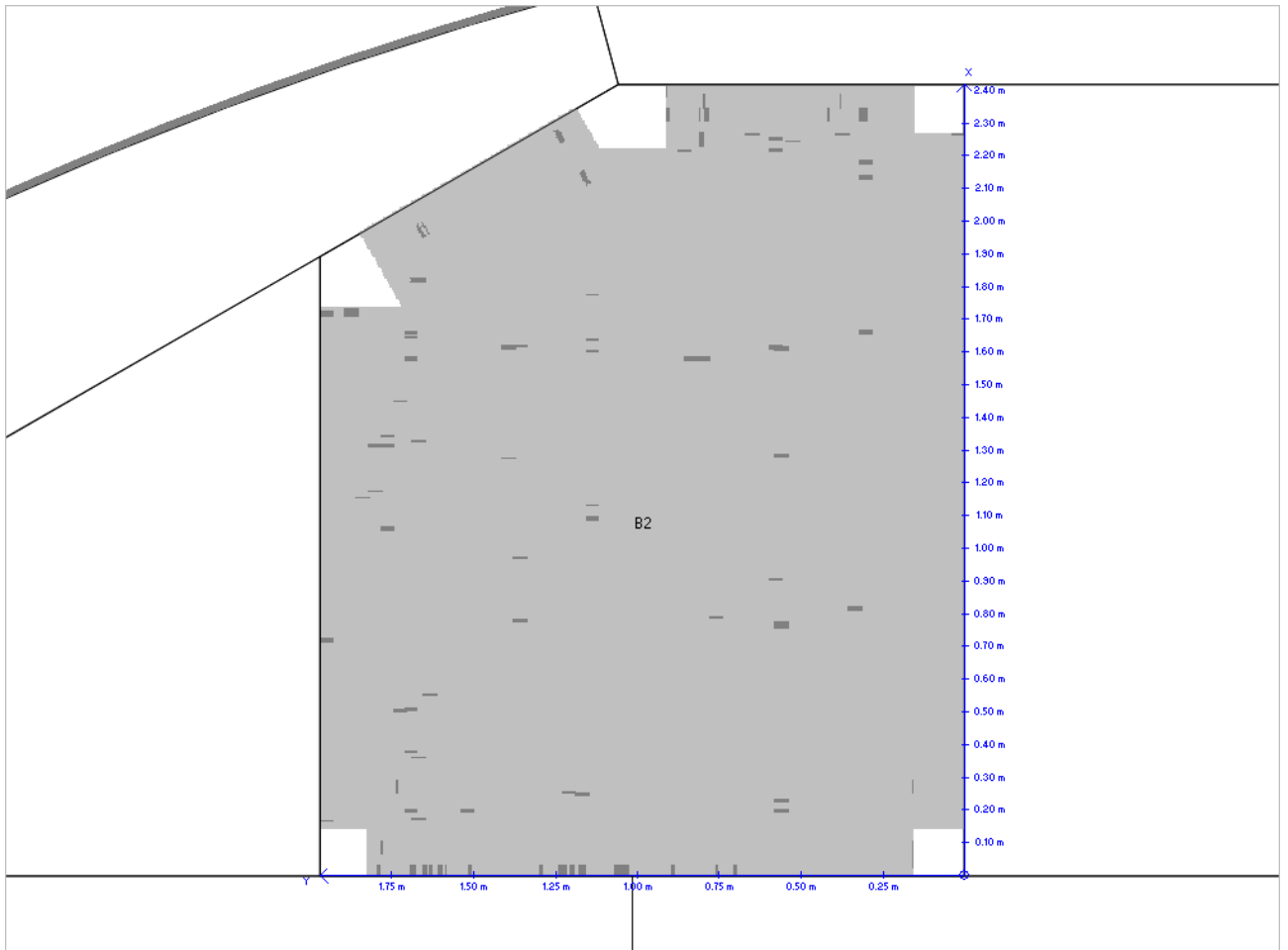

<ul style="list-style-type: none"> : Client a : Site b : 03/05/2016 : B 3 	<ul style="list-style-type: none"> : Tank 123 : K0xx-16 : Jxx86
---	--

Underside-Differential

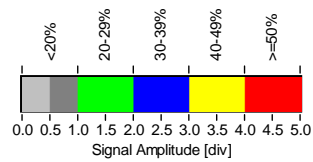
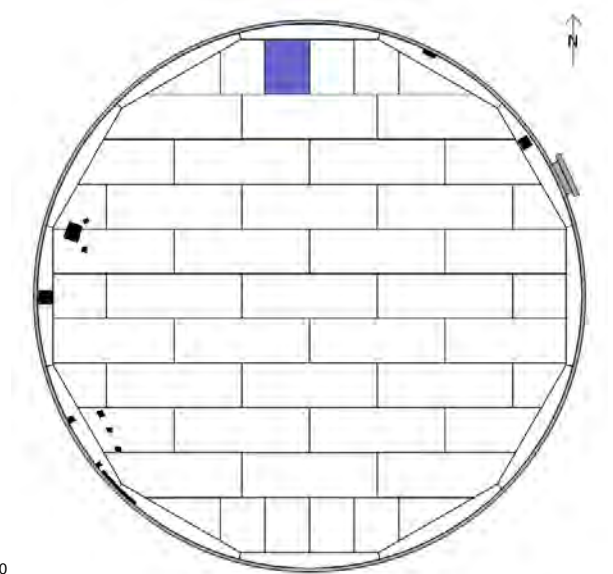
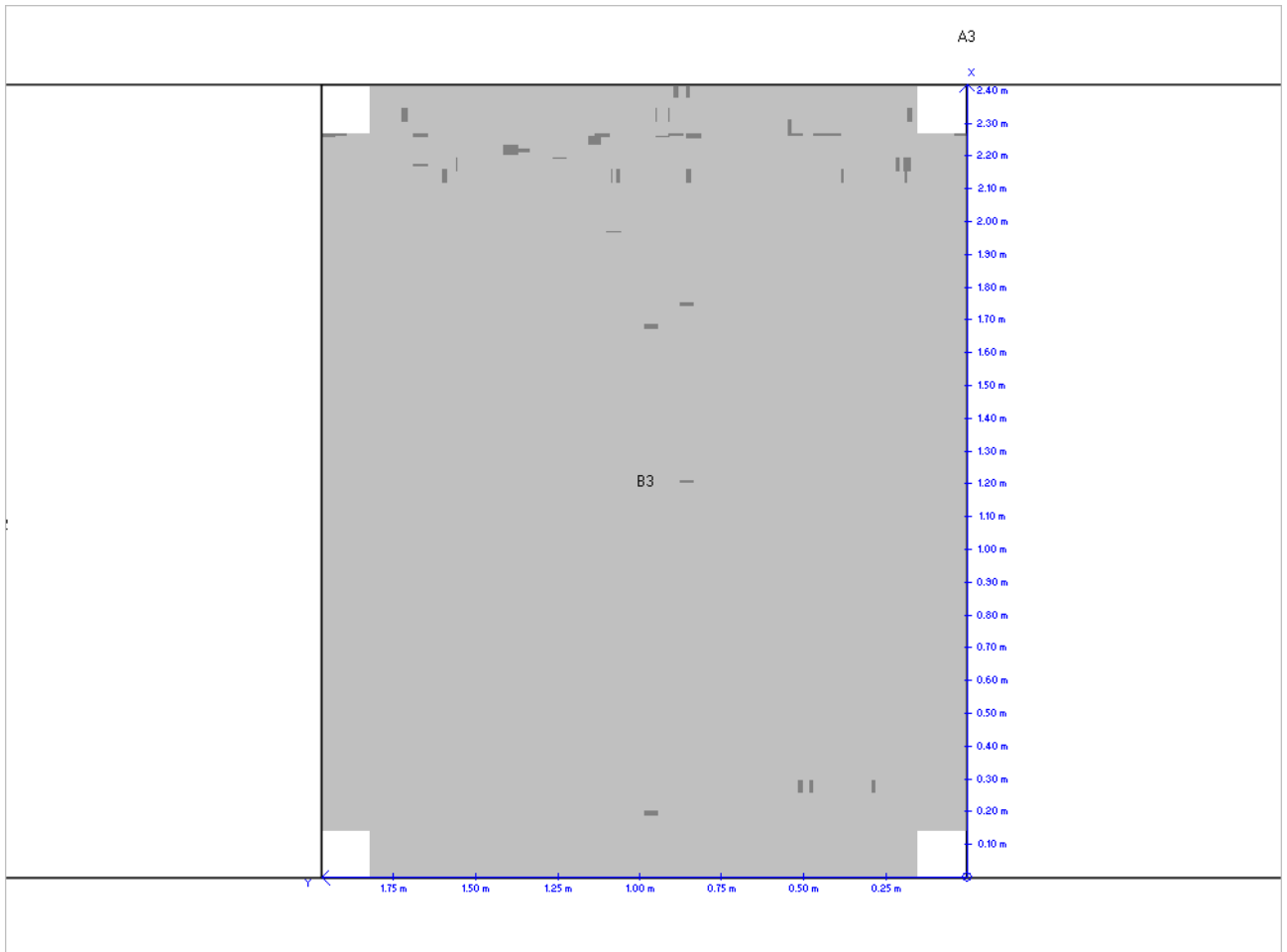

<ul style="list-style-type: none"> : Client a : Site b : 03/05/2016 : B 4 	<ul style="list-style-type: none"> : Tank 123 : K0xx-16 : Jxx86
---	--

Underside-Differential

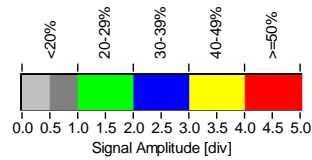
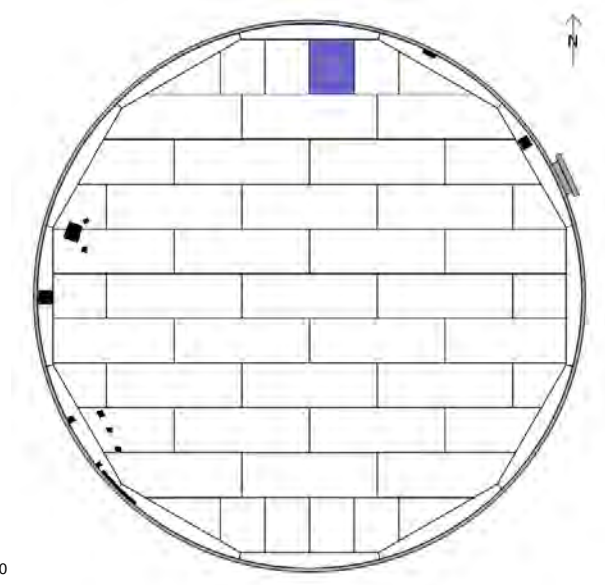
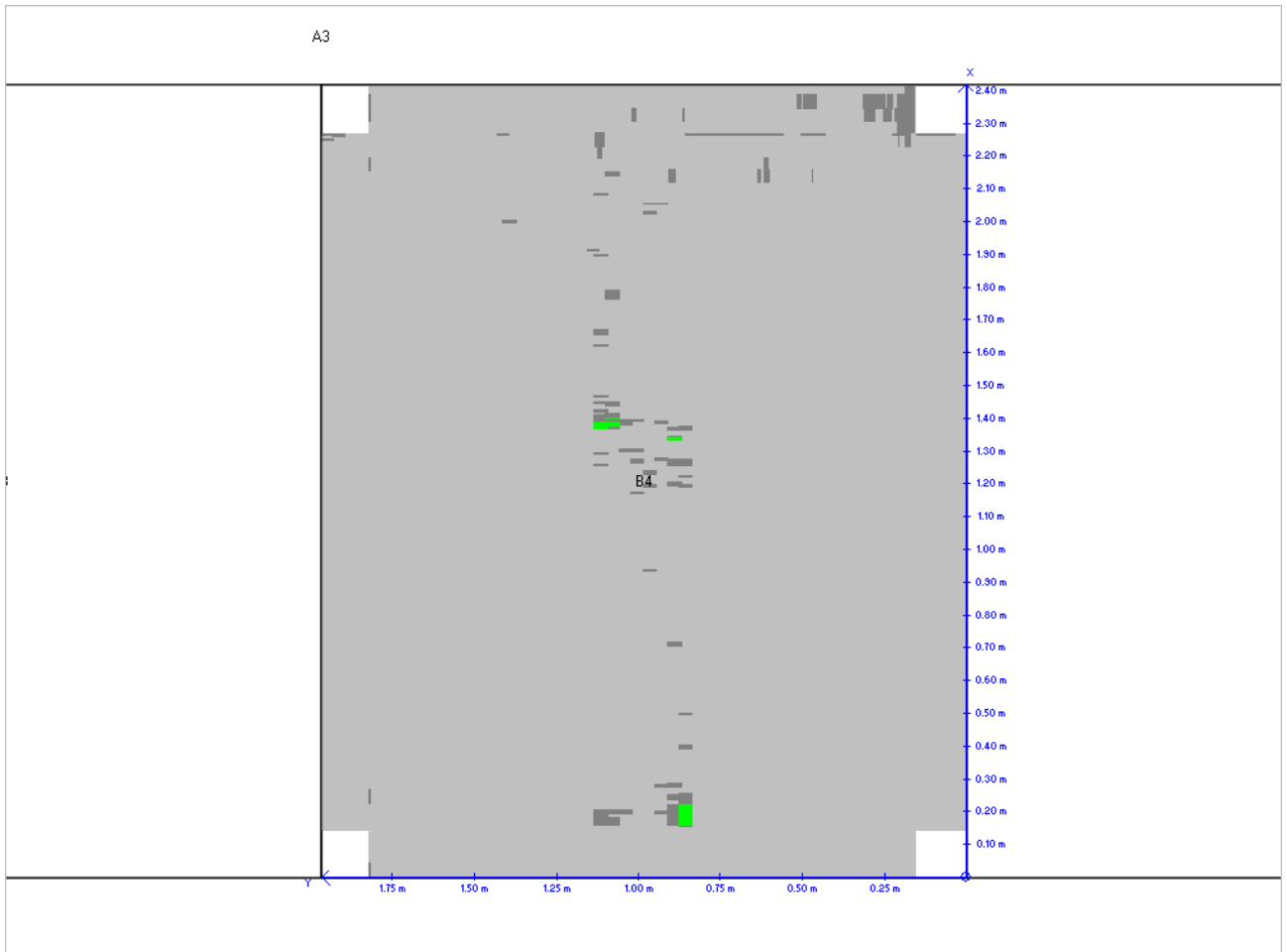

<ul style="list-style-type: none"> : Client a : Site b : 03/05/2016 : B 5 	<ul style="list-style-type: none"> : Tank123 : K0xx-16 : Jxx86
---	---

Underside-Differential

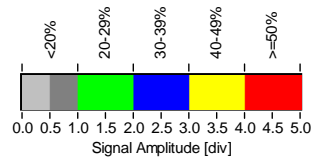
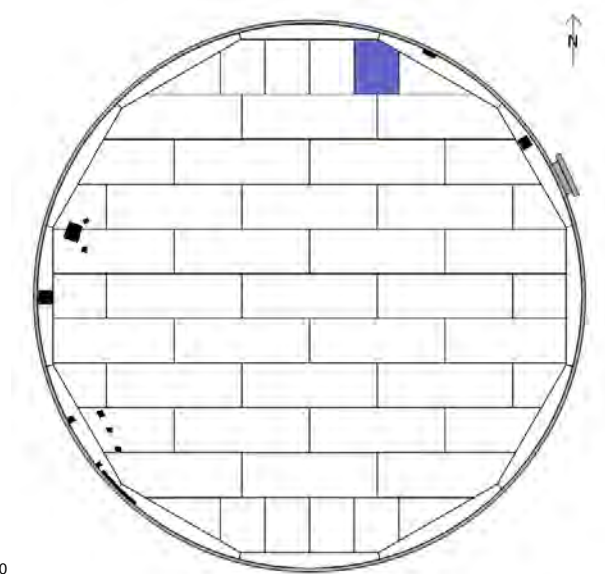
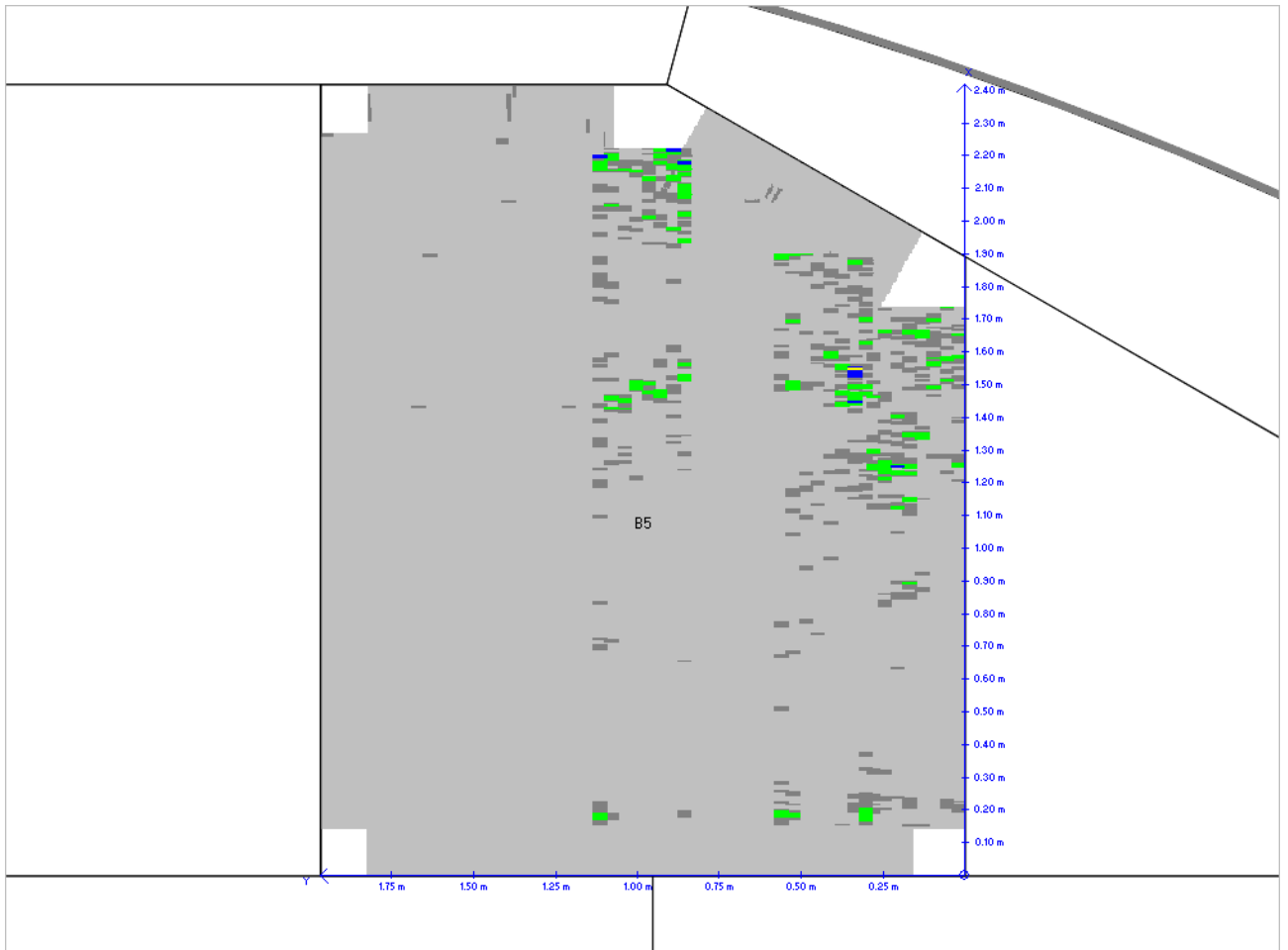

<ul style="list-style-type: none"> : Client a : Site b : 03/05/2016 : B 6 	<ul style="list-style-type: none"> : Tank 123 : K0xx-16 : Jxx86
---	--

Underside-Differential

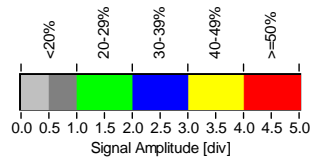
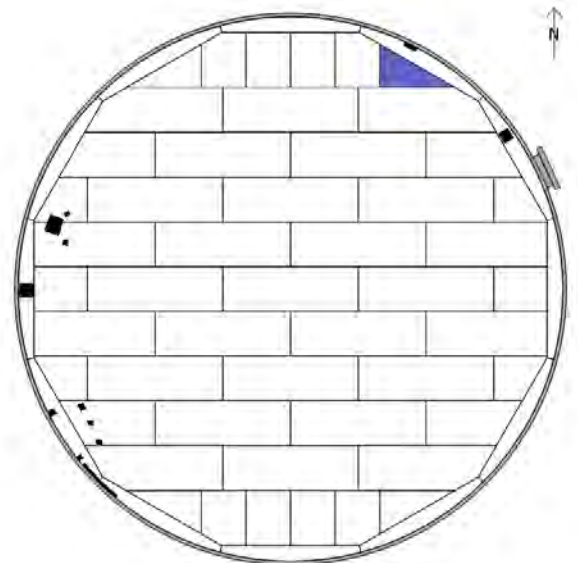
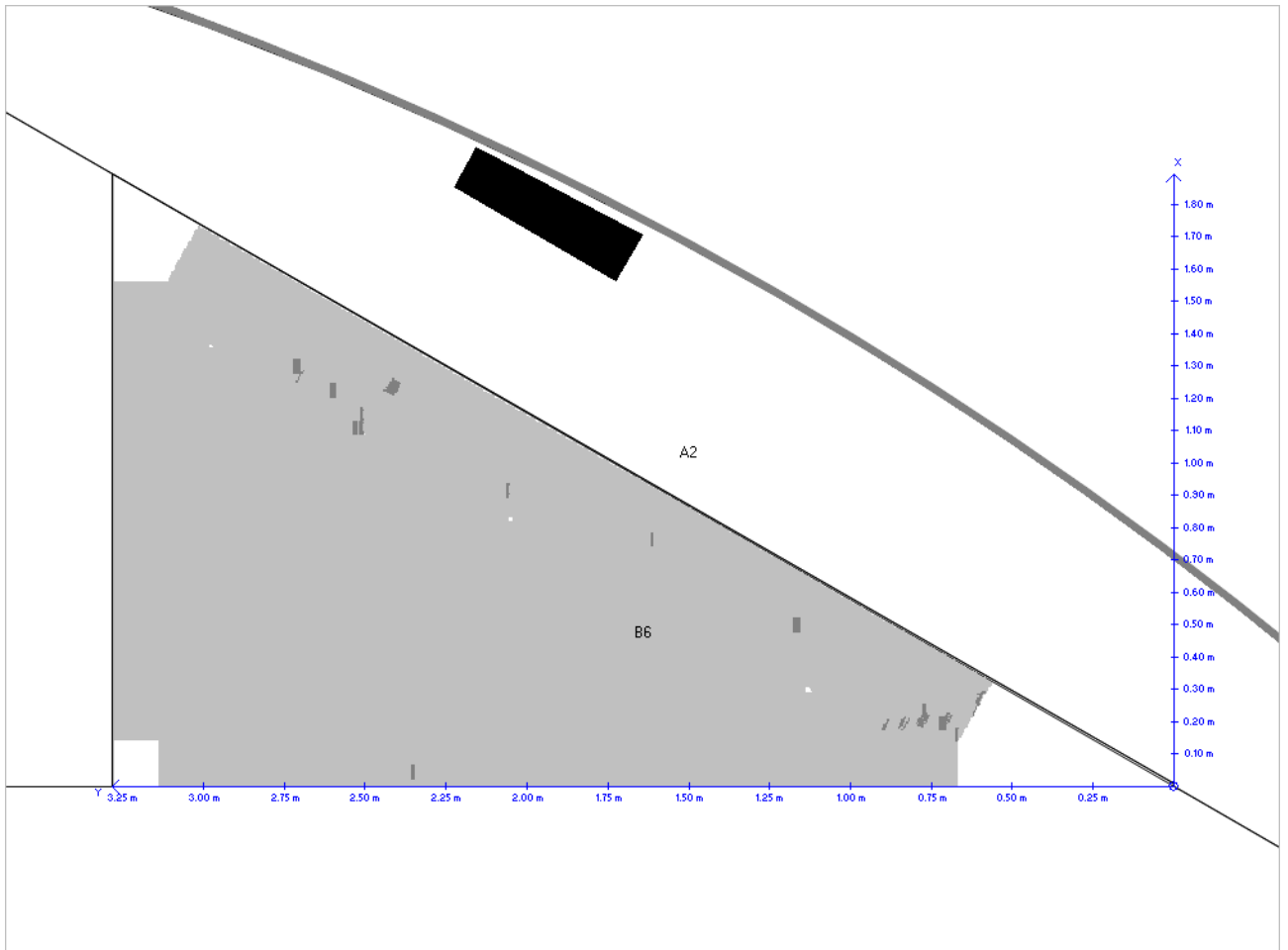

: Client : Site b : 03/05/2016 : B 7	: Tank 123 : K0xx-16 : Jxx86
---	------------------------------------

Underside-Differential

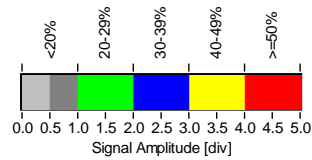
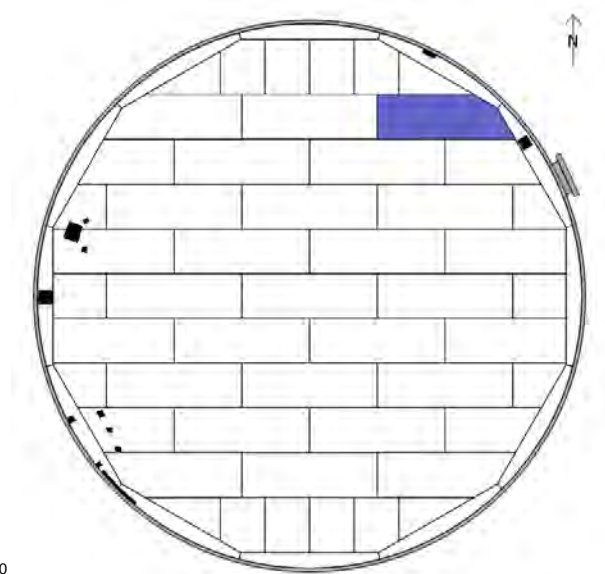
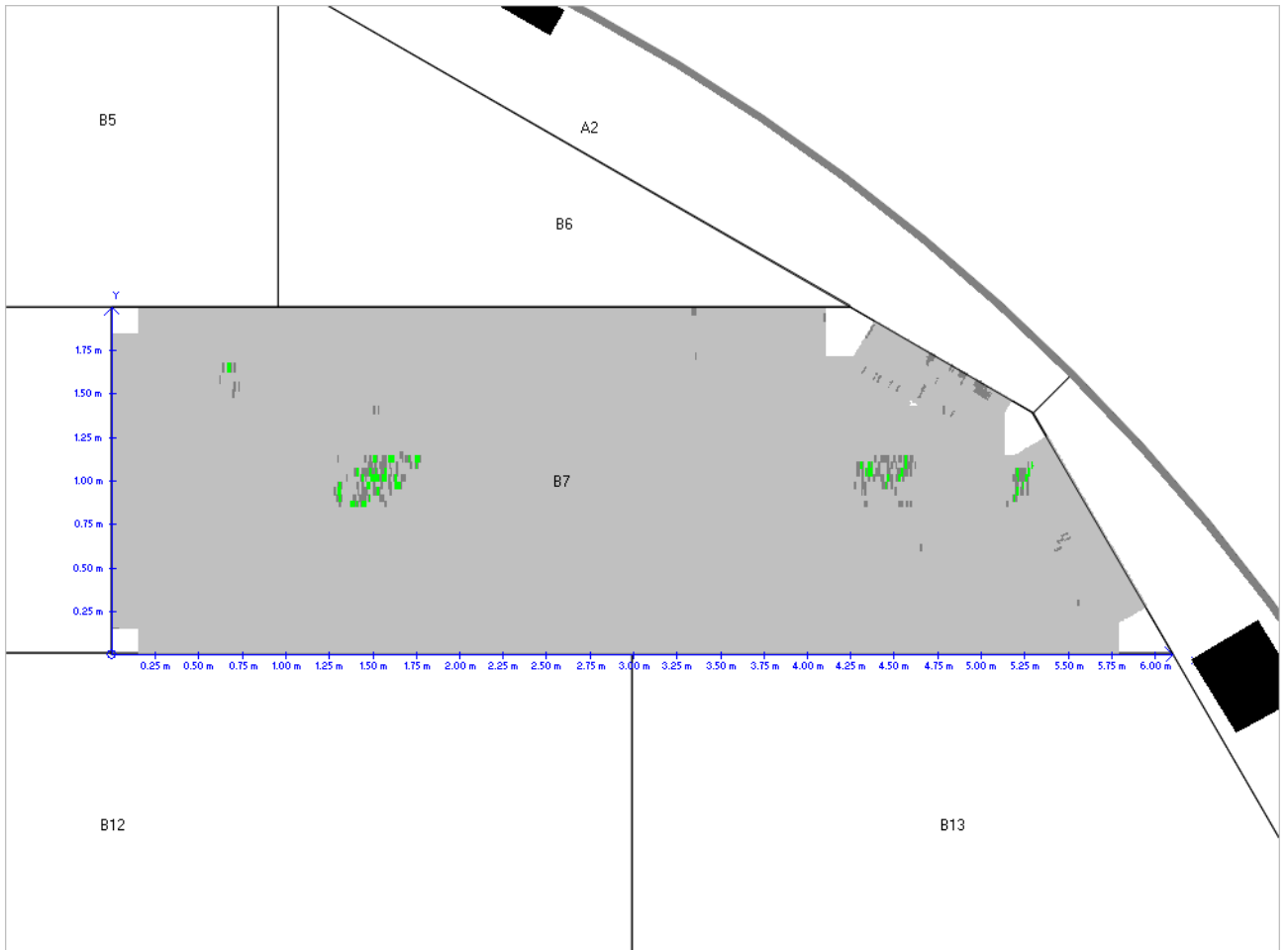

: Client a : Site b : 03/05/2016 : B 8	: Tank 123 : K0xx-16 : Jxx86
---	------------------------------------

Underside-Differential

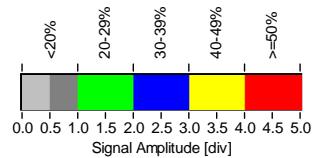
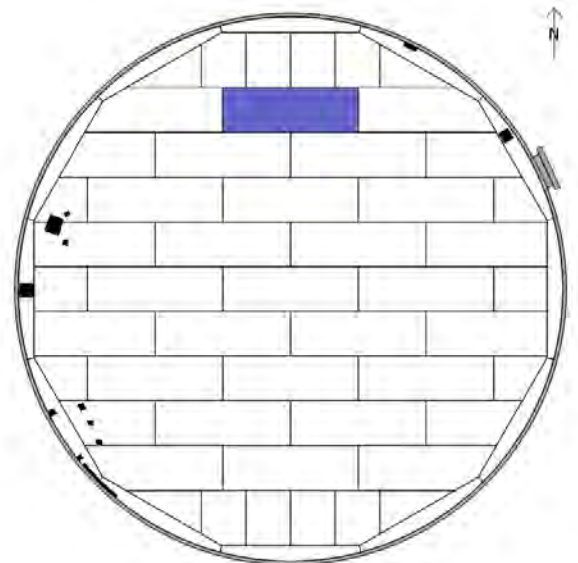
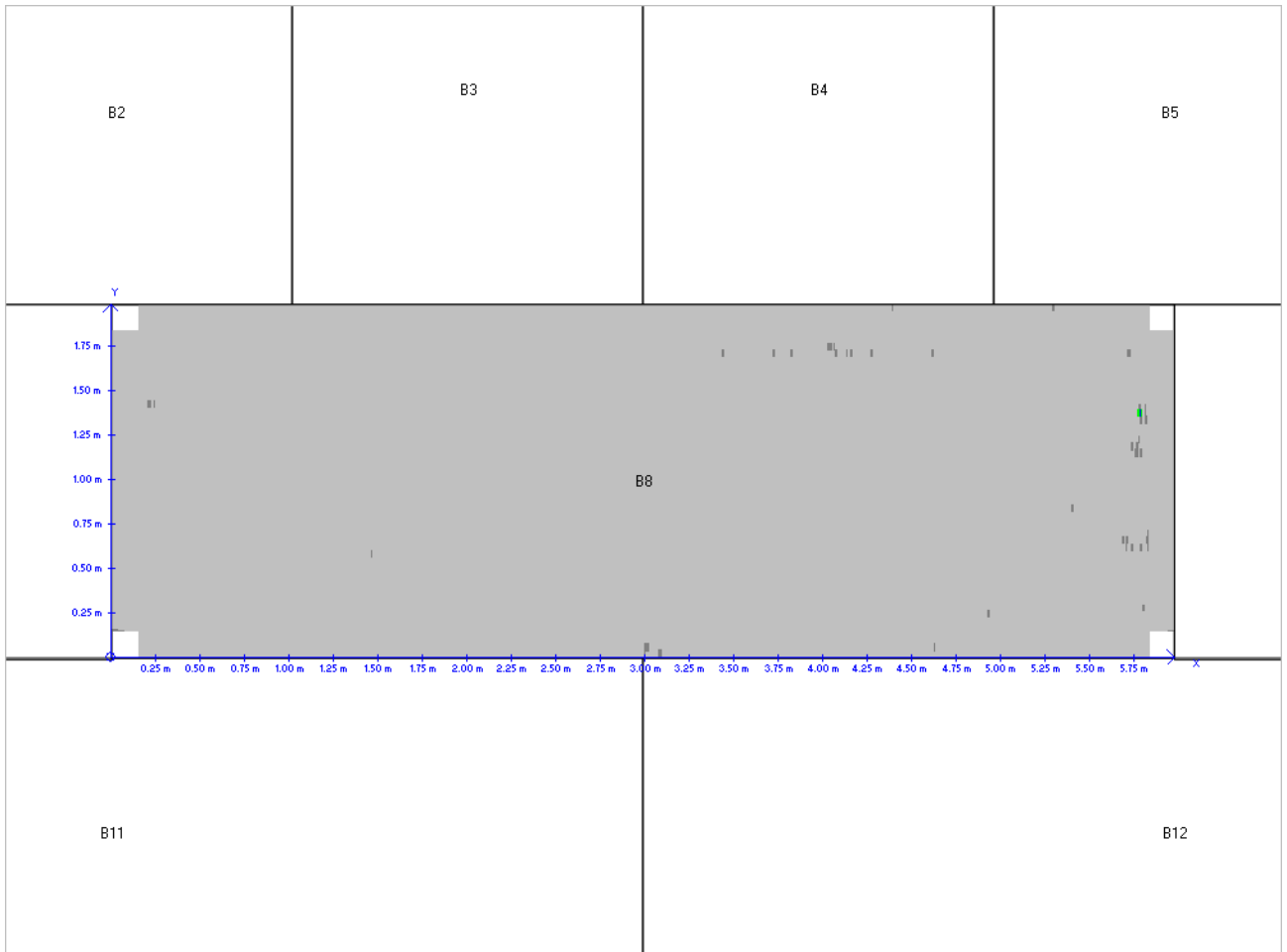

<ul style="list-style-type: none"> : Client a : Site 123 : 03/05/2016 : B 9 	<ul style="list-style-type: none"> : Tank 123 : K0xx-16 : Jxx86
---	--

Underside-Differential

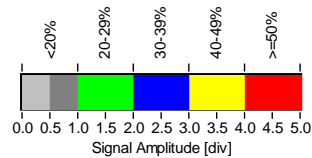
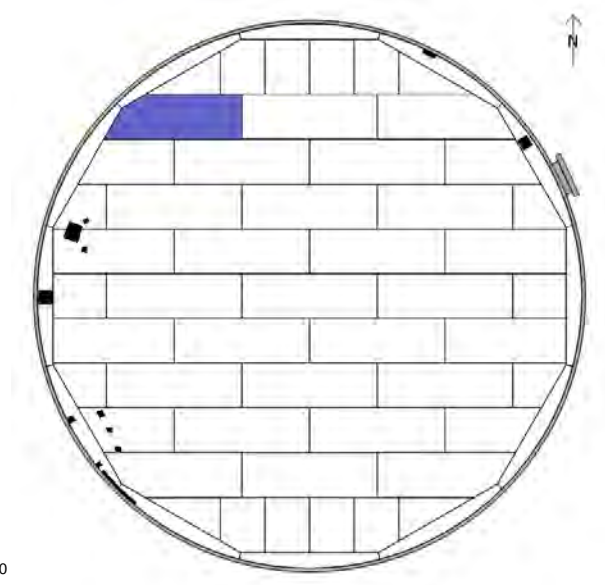
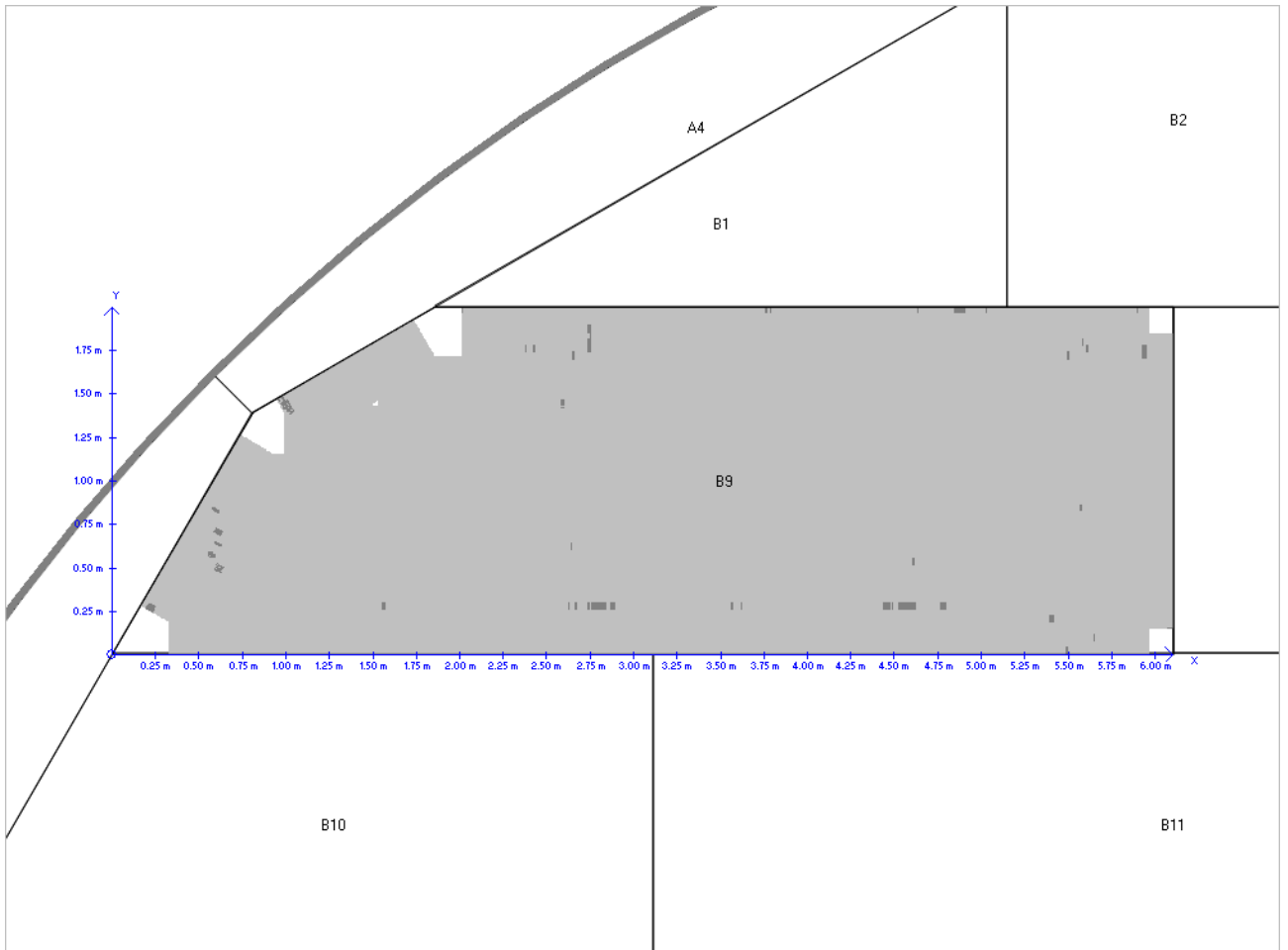

<ul style="list-style-type: none"> : Client a : Site b : 03/05/2016 : B 10 	<ul style="list-style-type: none"> : Tank 123 : K0xx-16 : Jxx86
--	--

Underside-Differential

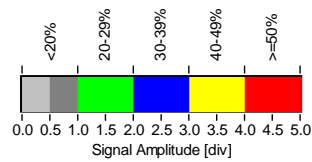
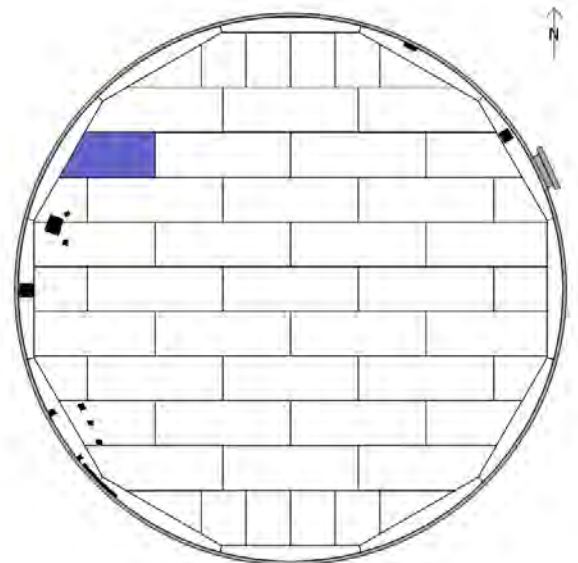
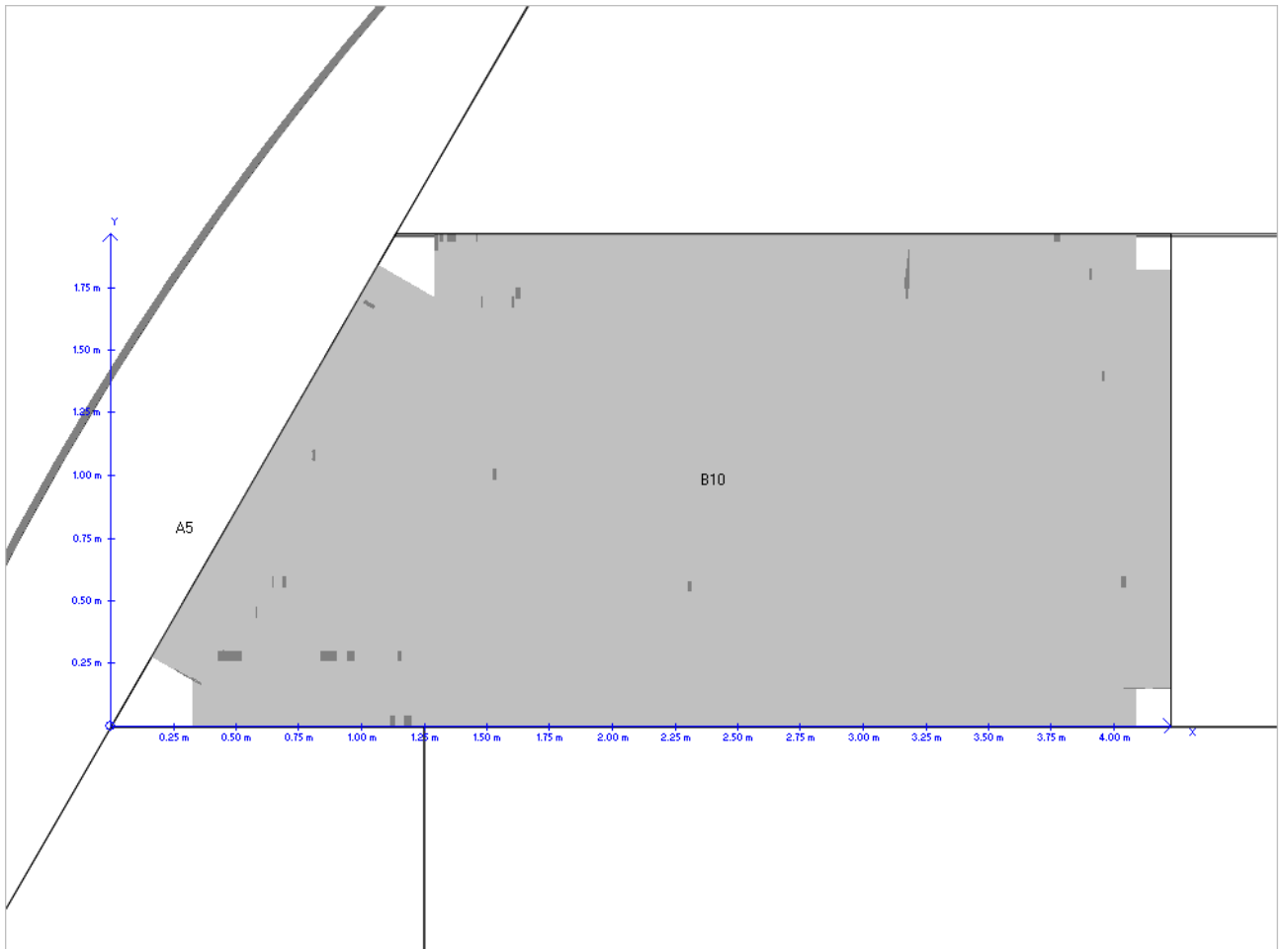

: Client a : Site b : 03/05/2016 : B 11	: Tank 123 : K0xx-16 : Jxx86
--	------------------------------------

Underside-Differential

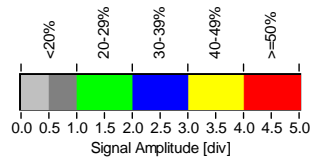
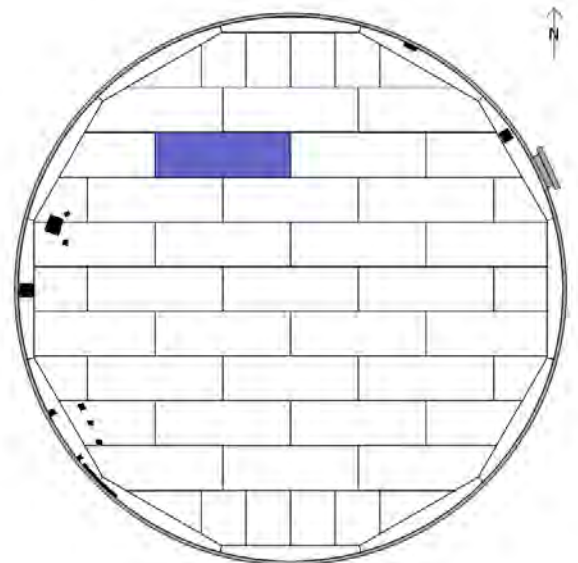
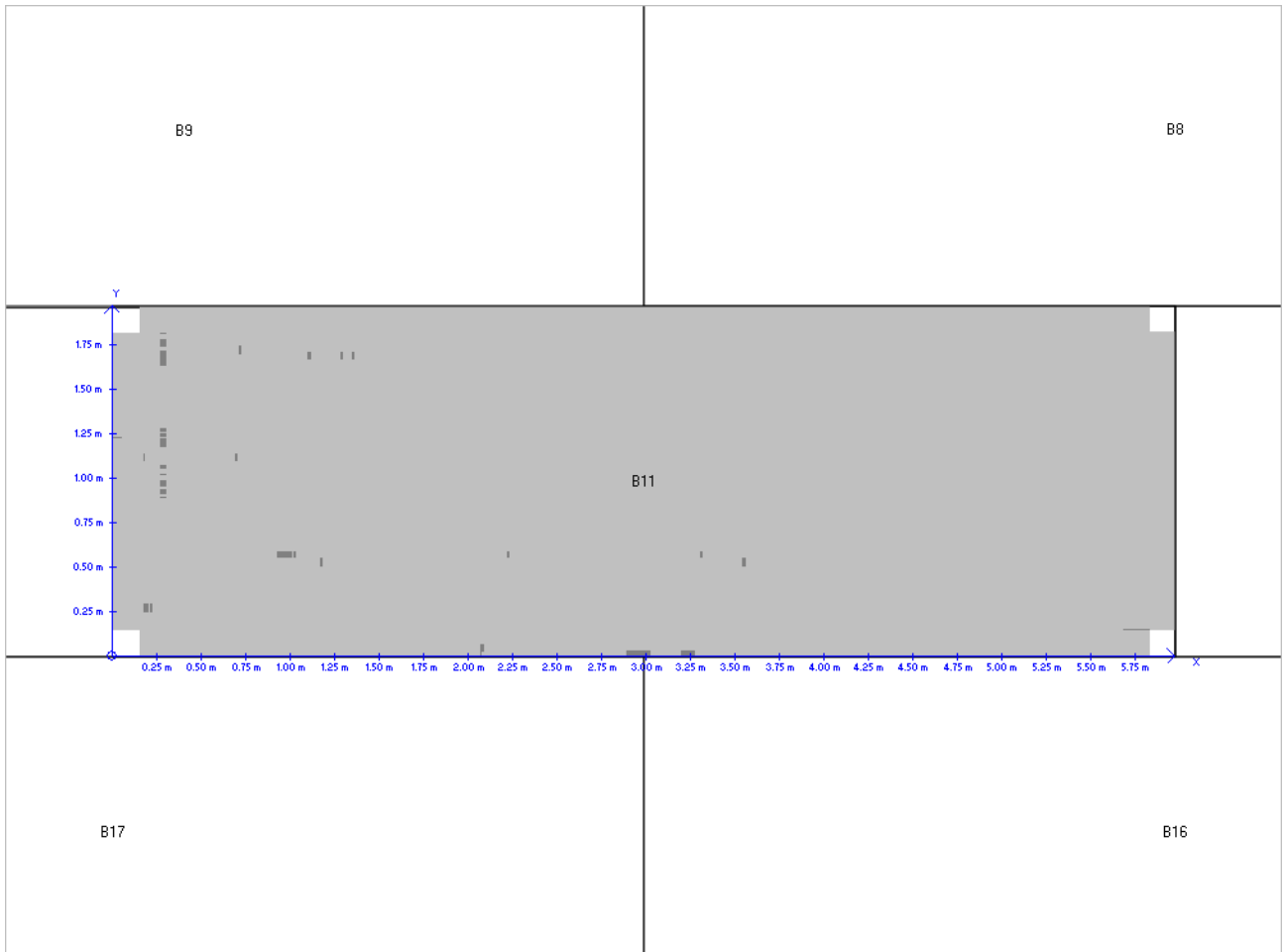

: Client x : Site b : 03/05/2016 : B 12	: Tank 123 : K0xx-16 : Jxx86
--	------------------------------------

Underside-Differential

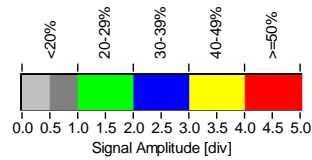
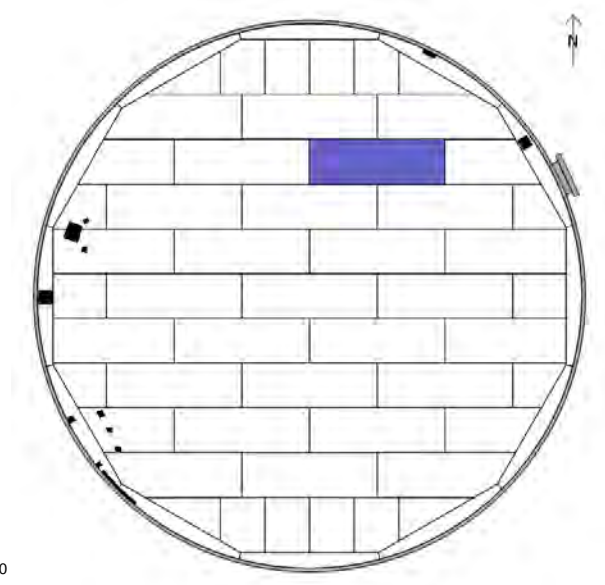
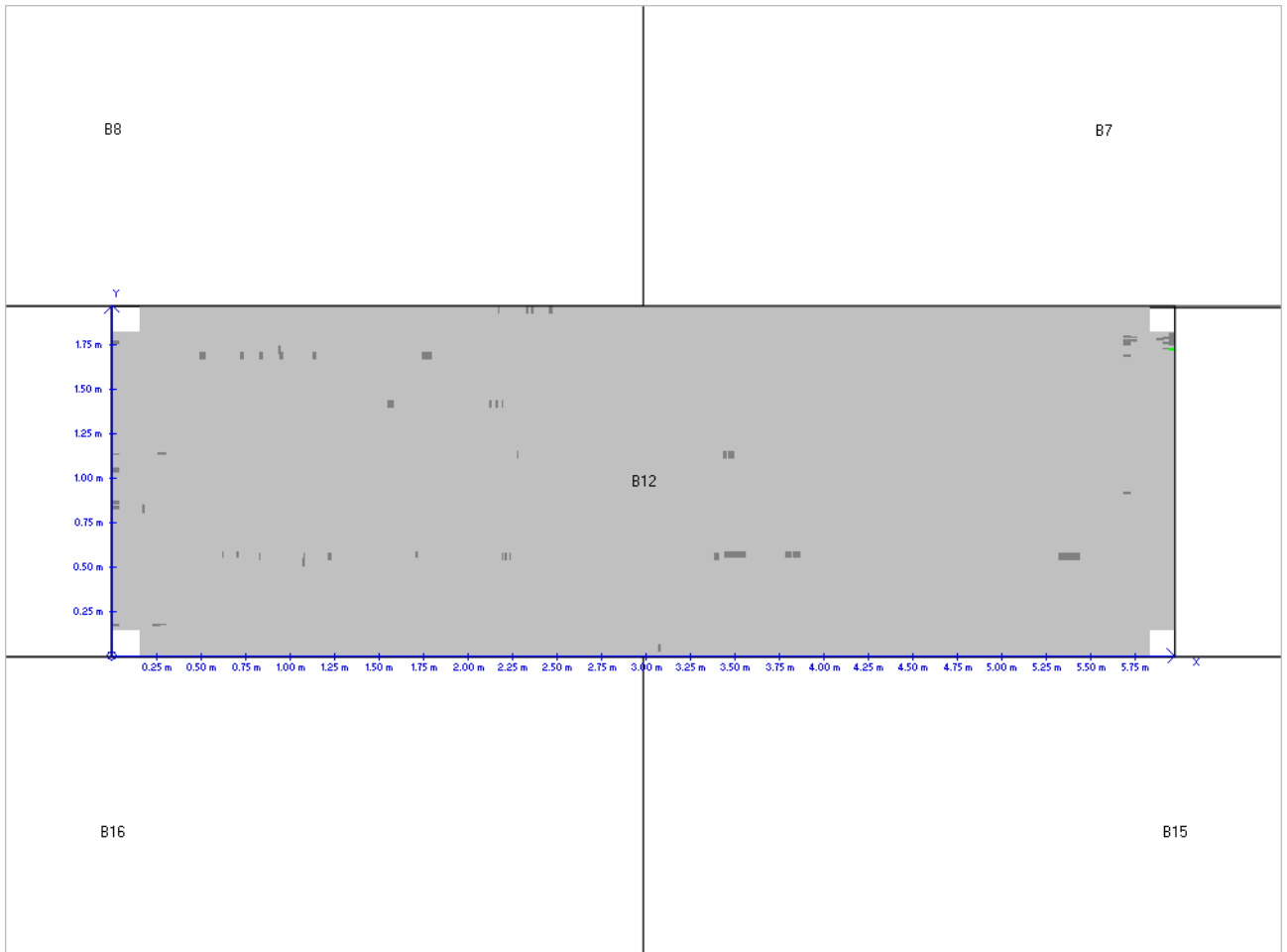

<ul style="list-style-type: none"> : Client a : Site b : 03/05/2016 : B 13 	<ul style="list-style-type: none"> : Tank 123 : K0xx-16 : Jxx86
--	--

Underside-Differential

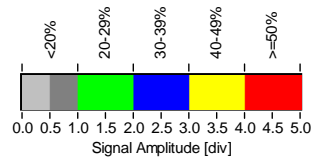
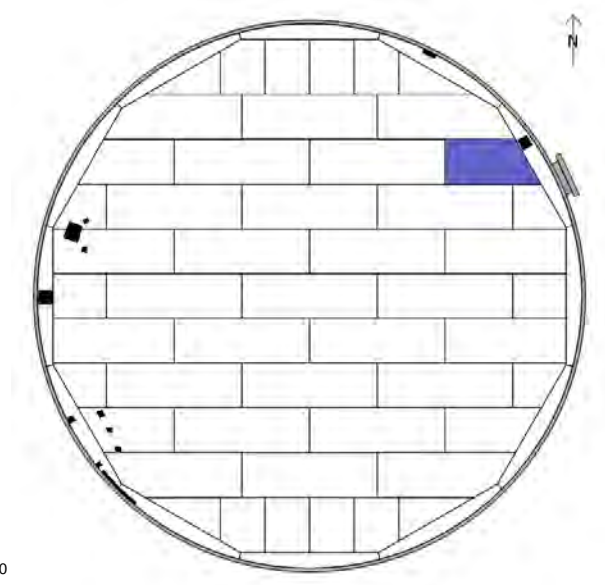
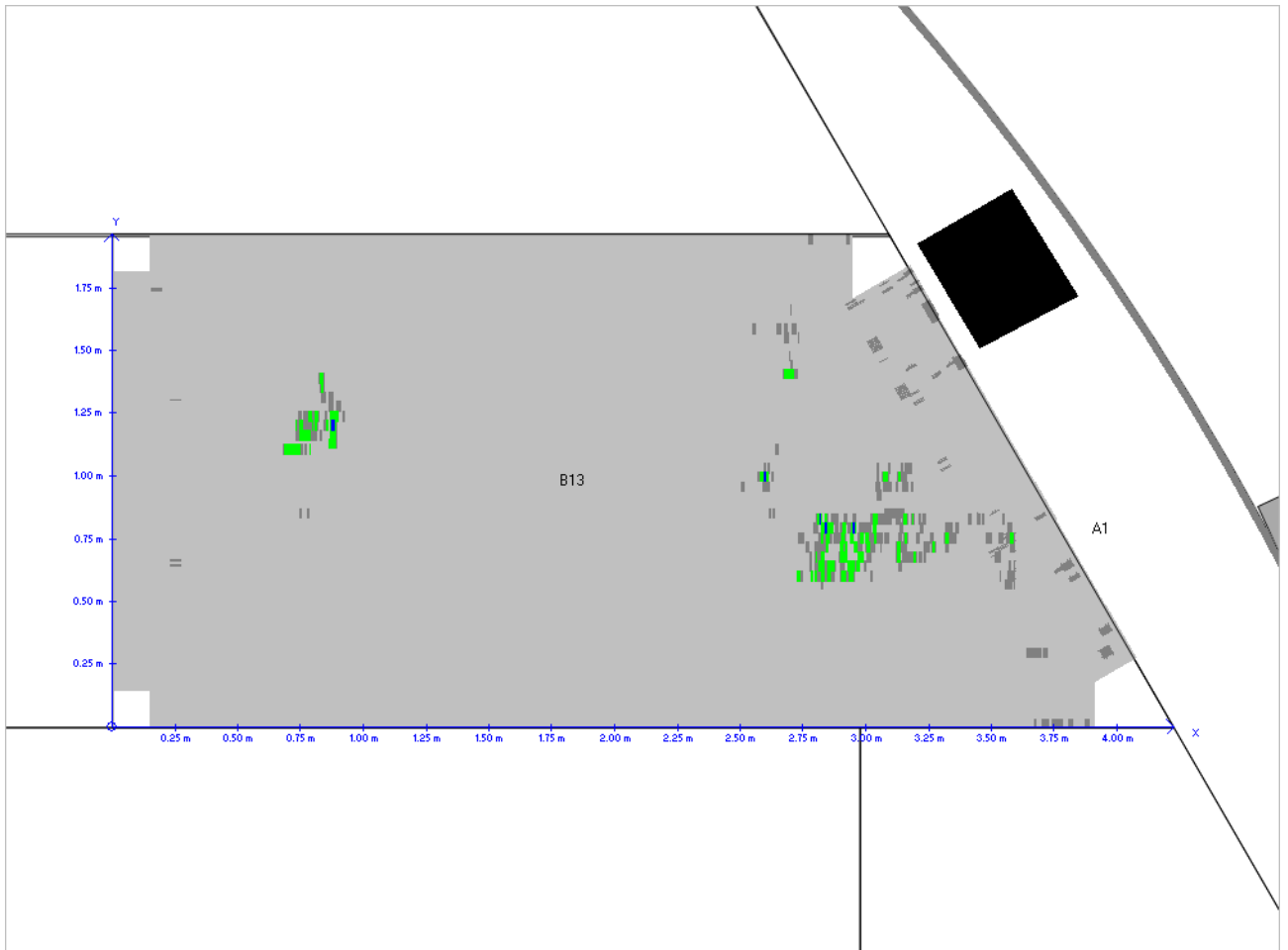

<ul style="list-style-type: none"> : Client a : Site b : 03/05/2016 : B 14 	<ul style="list-style-type: none"> : Tank 123 : K0xx-16 : Jxx86
--	--

Underside-Differential

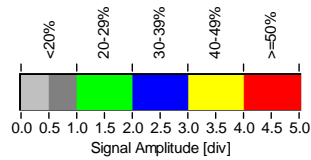
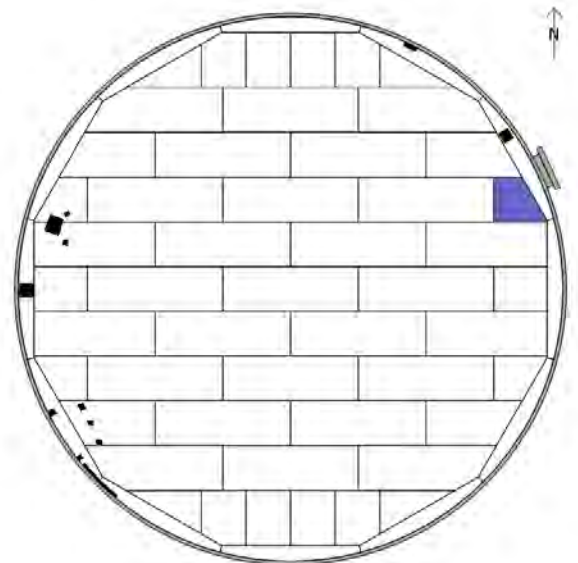
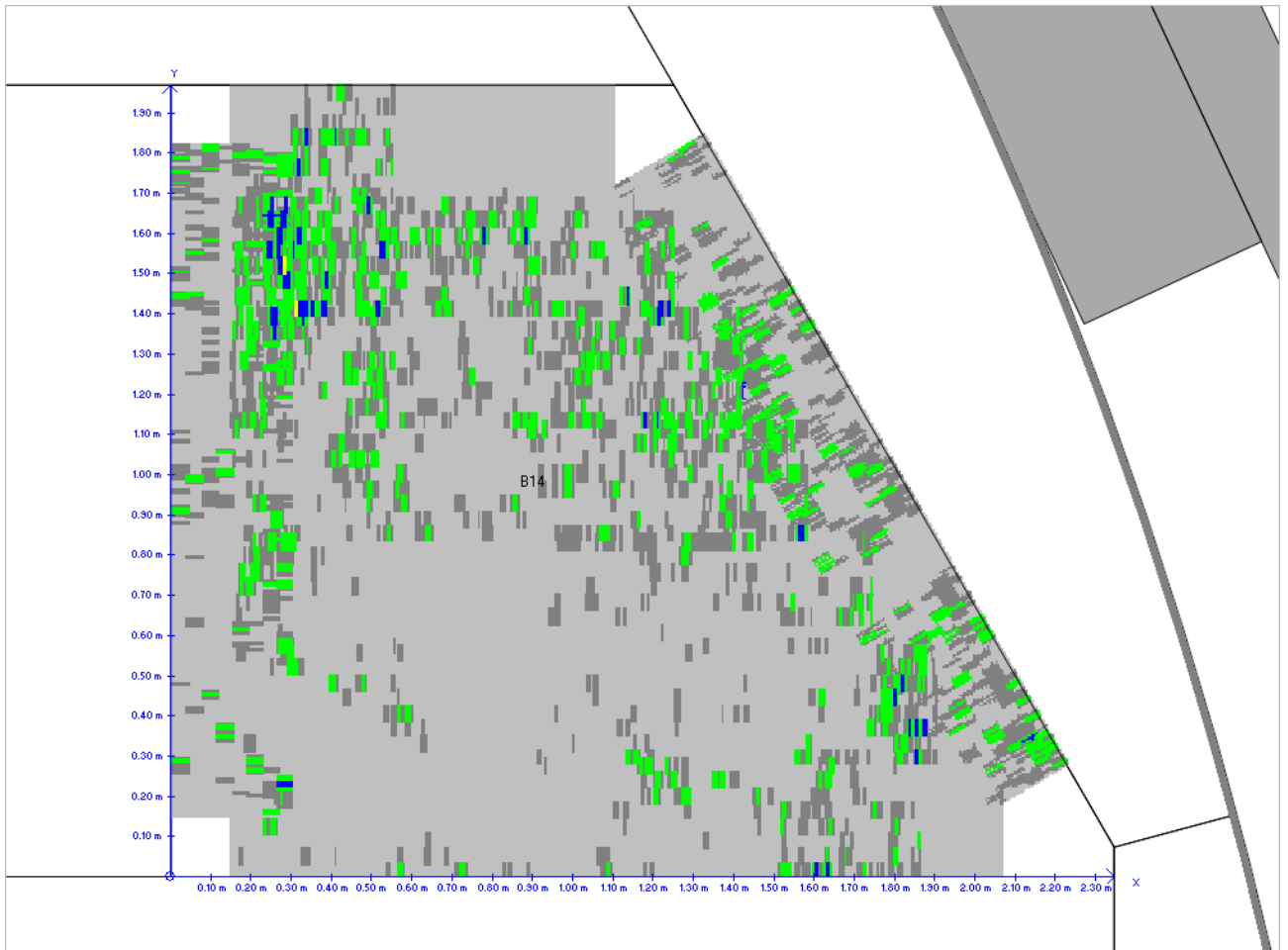

<ul style="list-style-type: none"> : Client a : Site b : 03/05/2016 : B 15 	<ul style="list-style-type: none"> : Tank 123 : K0xx-16 : Jxx86
--	--

Underside-Differential

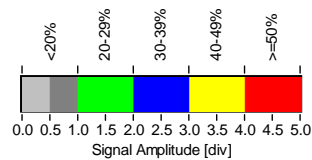
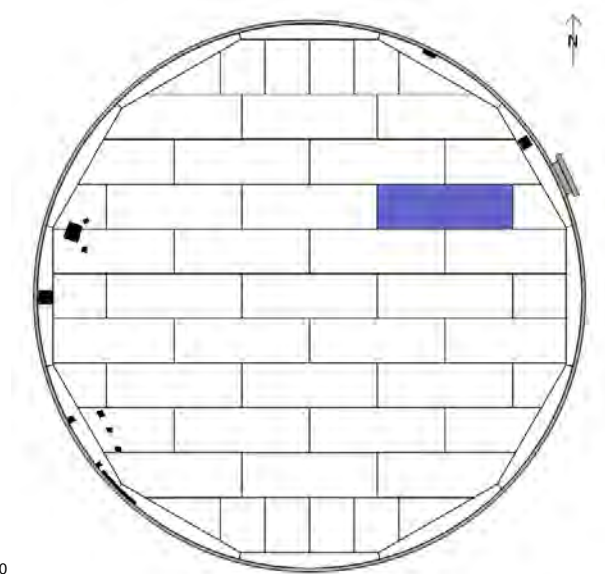
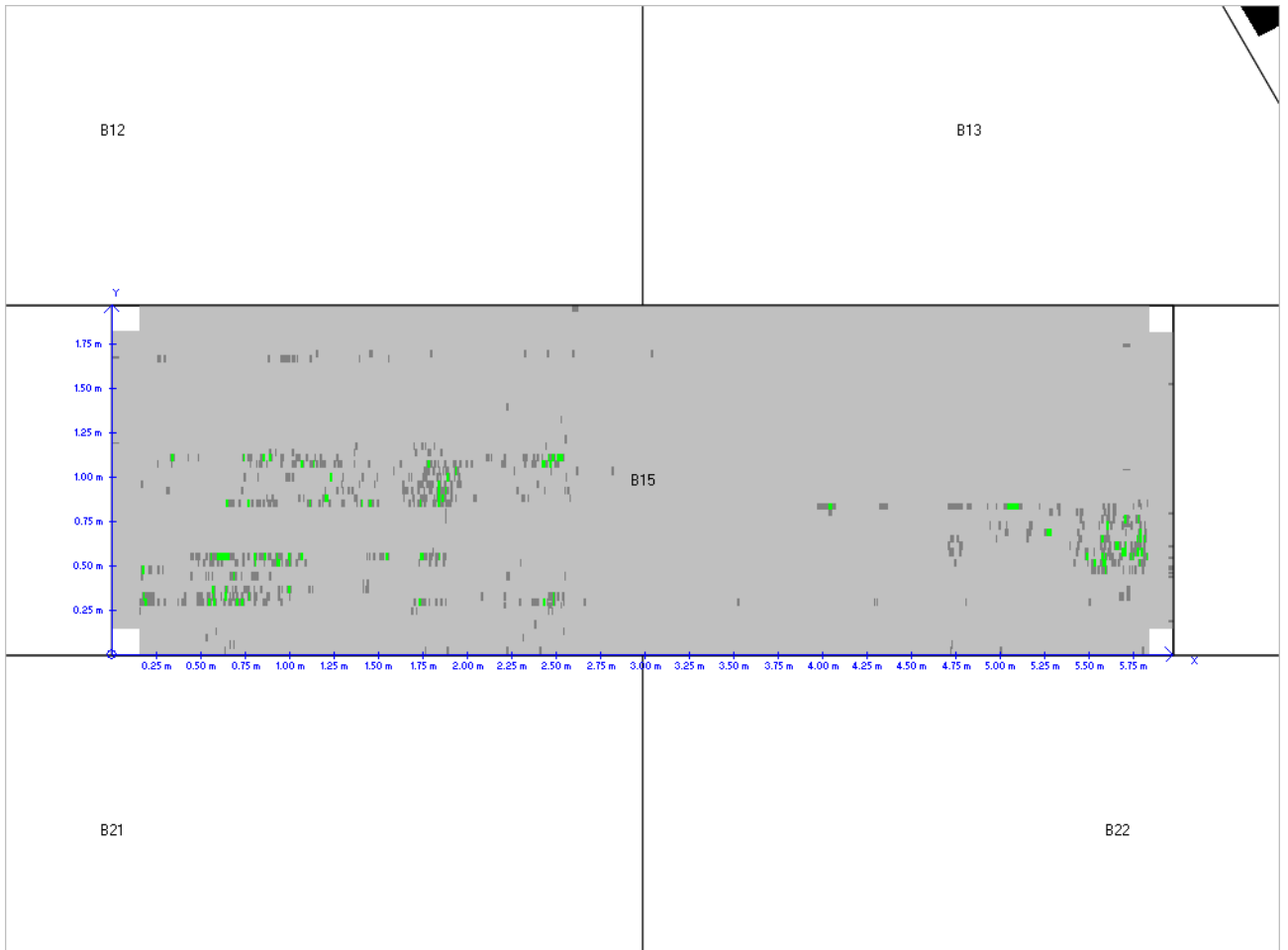

: Client a : Site b : 03/05/2016 : B 16	: Tank 123 : K0xx-16 : Jxx86
--	------------------------------------

Underside-Differential

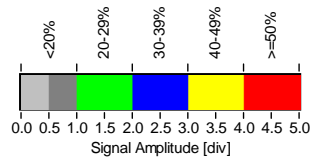
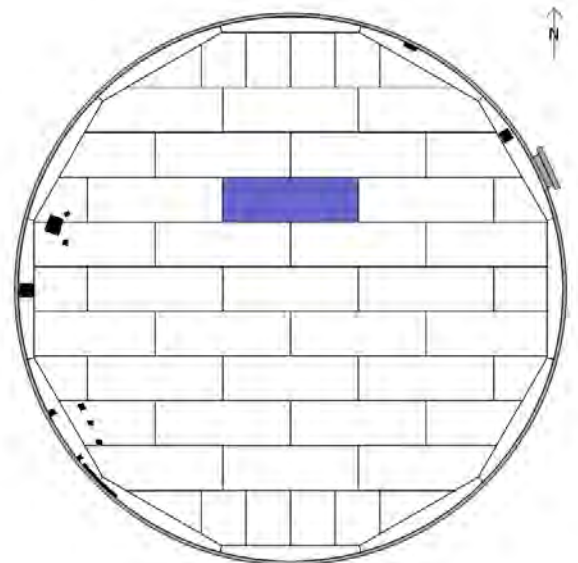
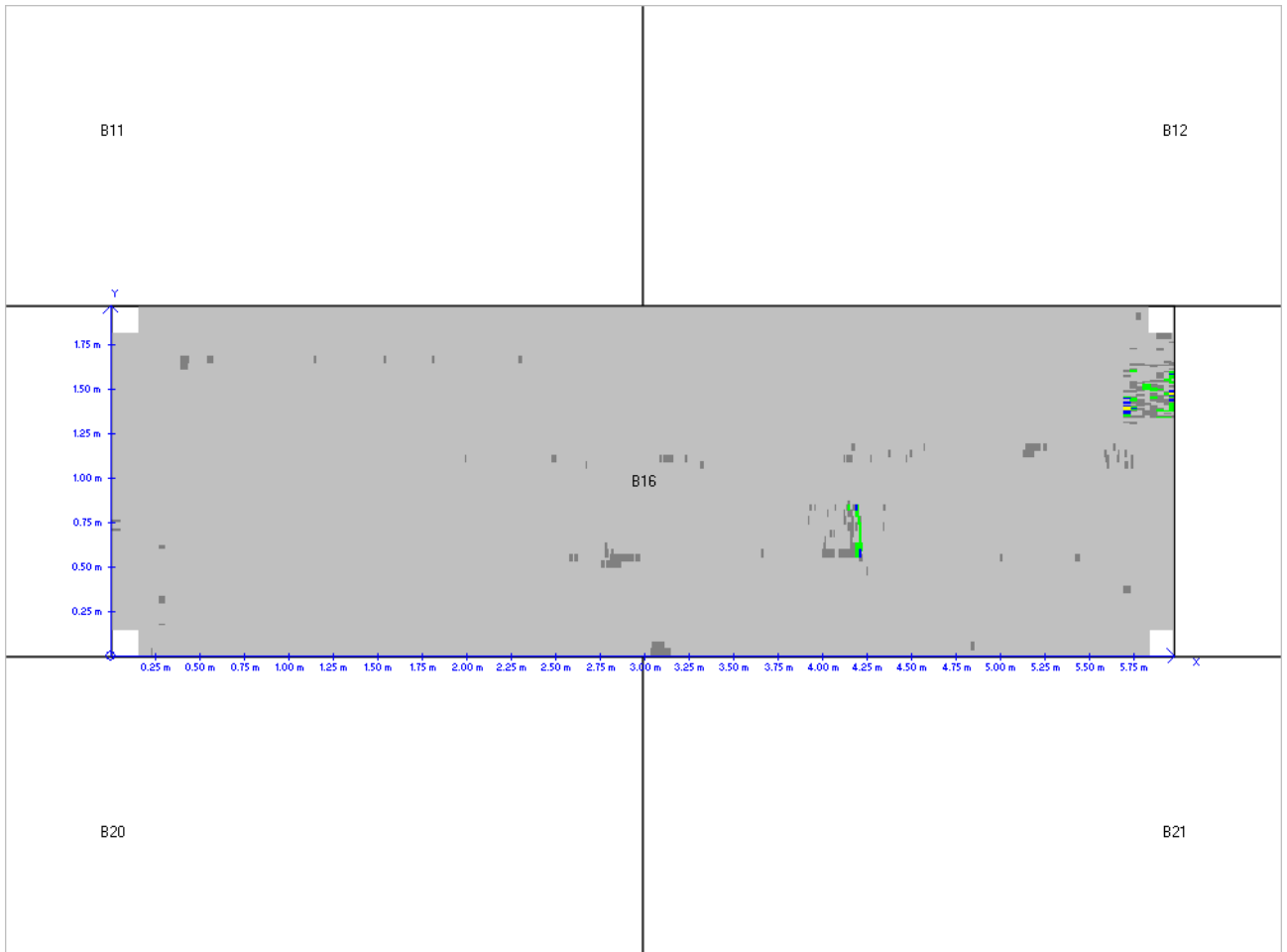

: Client a : Site b : 03/05/2016 : B 17	: Tank 123 : K0xx-16 : Jxx86
--	------------------------------------

Underside-Differential

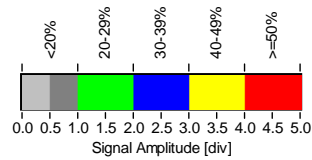
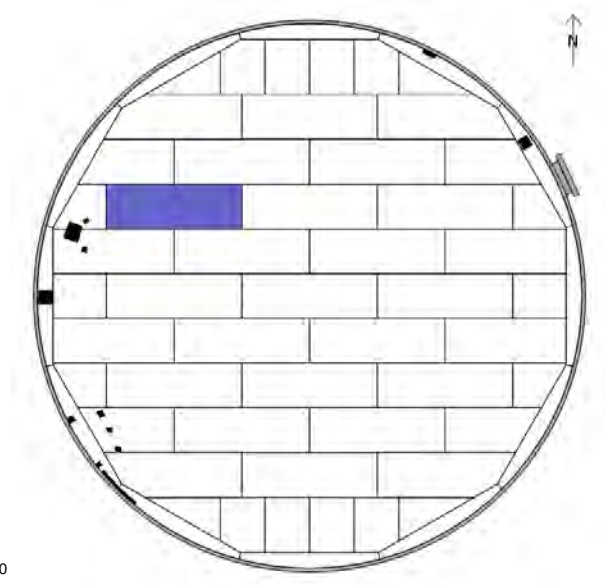
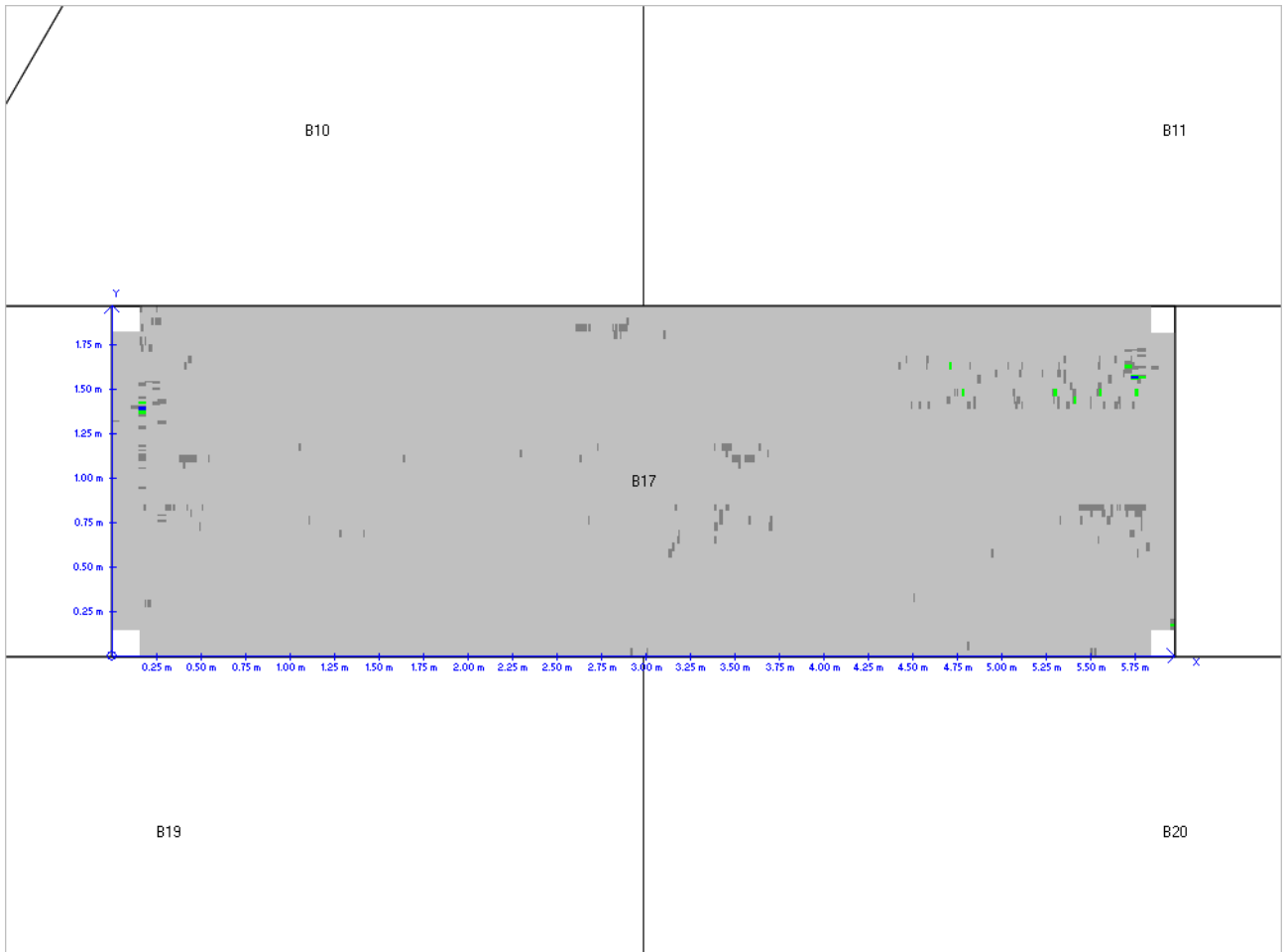

<ul style="list-style-type: none"> : Client a : Site b : 03/05/2016 : B 18 	<ul style="list-style-type: none"> : Tank 123 : K0xx-16 : Jxx86
--	--

Underside-Differential

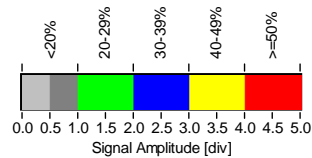
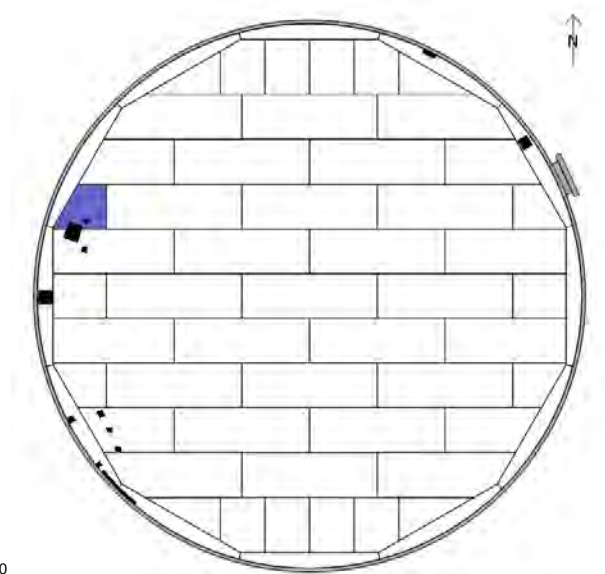
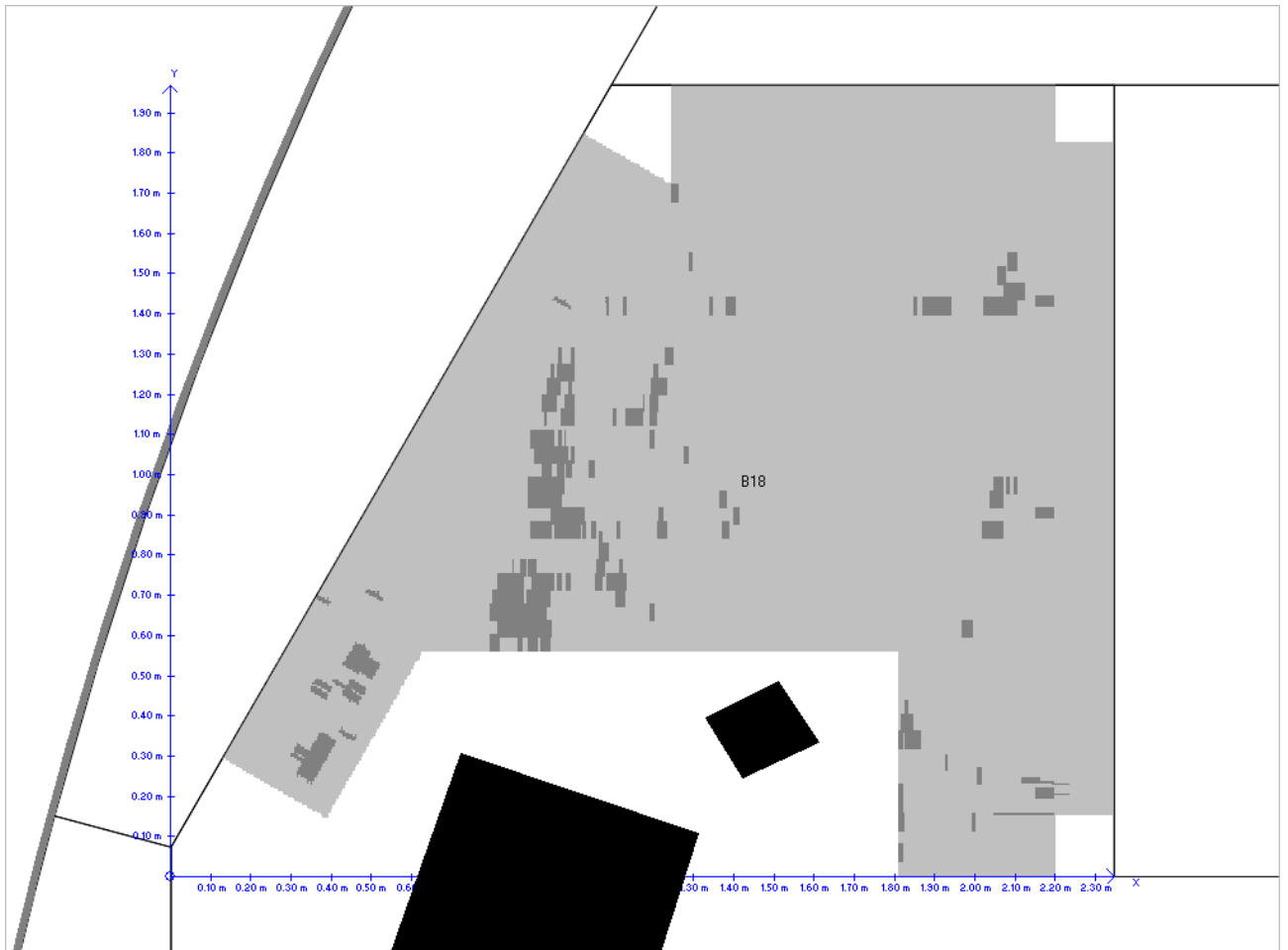

<ul style="list-style-type: none"> : Client a : Site b : 03/05/2016 : B 19 	<ul style="list-style-type: none"> : Tank 123 : K0xx-16 : Jxx86
--	--

Underside-Differential

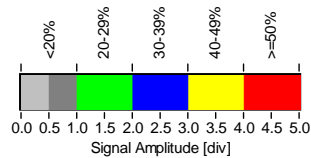
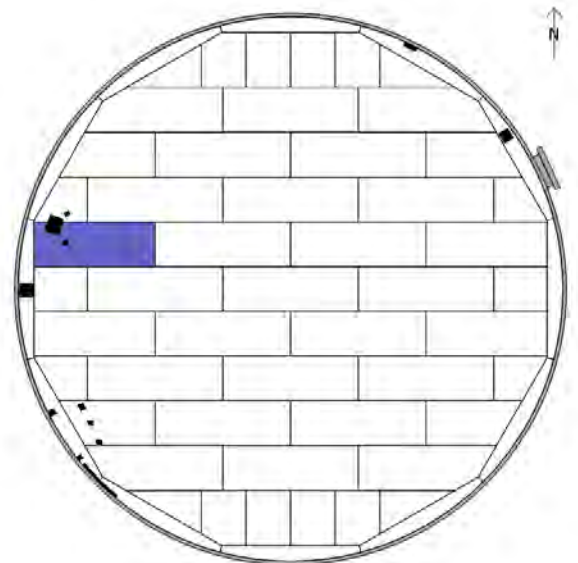
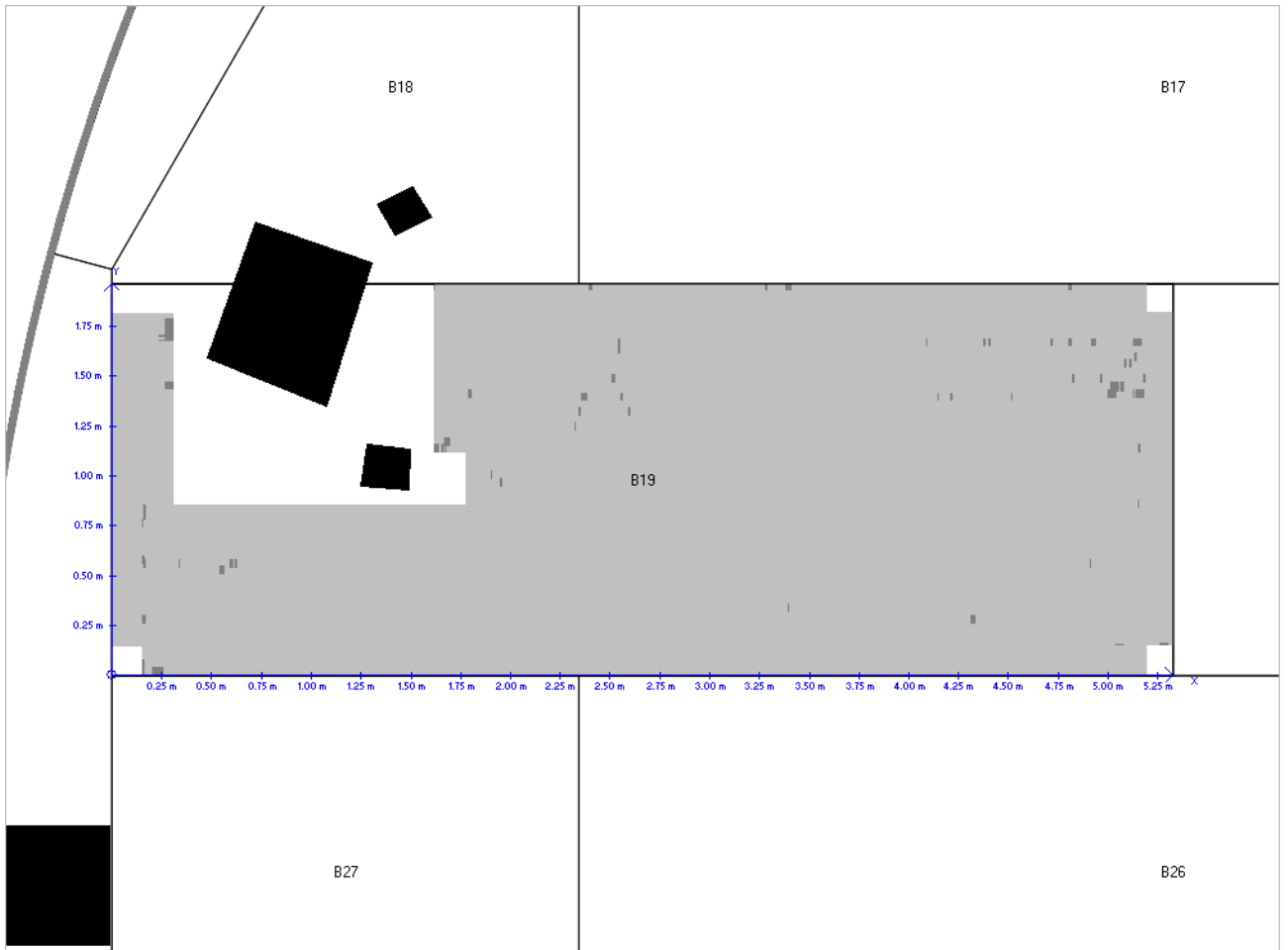

<ul style="list-style-type: none"> : Client a : Site b : 03/05/2016 : B 20 	<ul style="list-style-type: none"> : Tank 123 : K0xx-16 : Jxx86
--	--

Underside-Differential

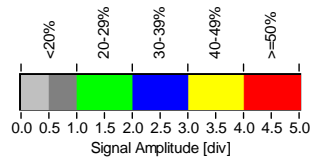
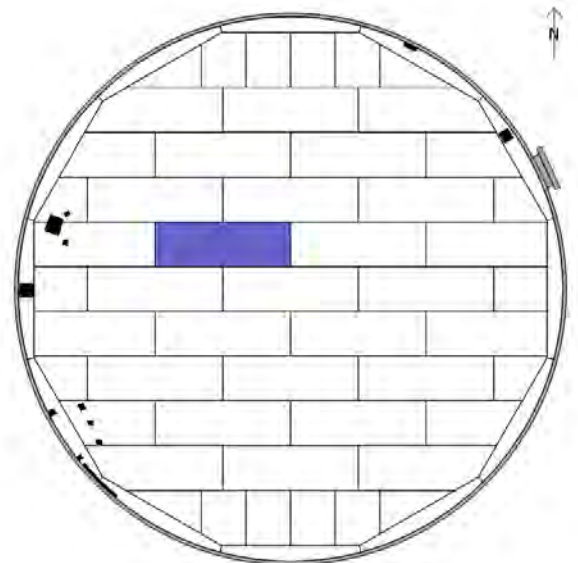
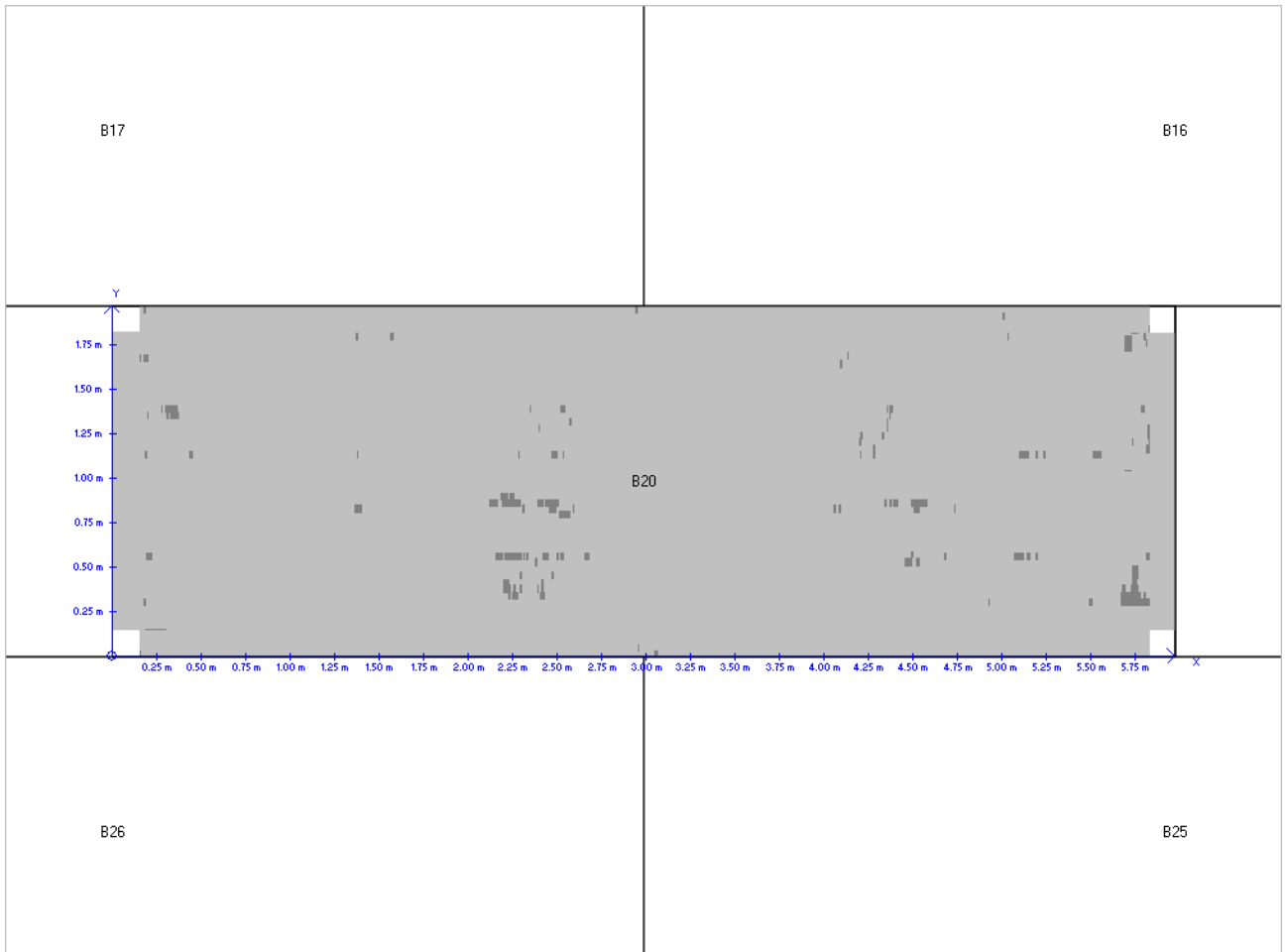

: Client a : Site b : 03/05/2016 : B 21	: Tank 123 : K0xx-16 : Jxx86
--	------------------------------------

Underside-Differential

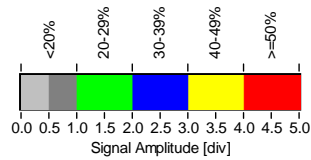
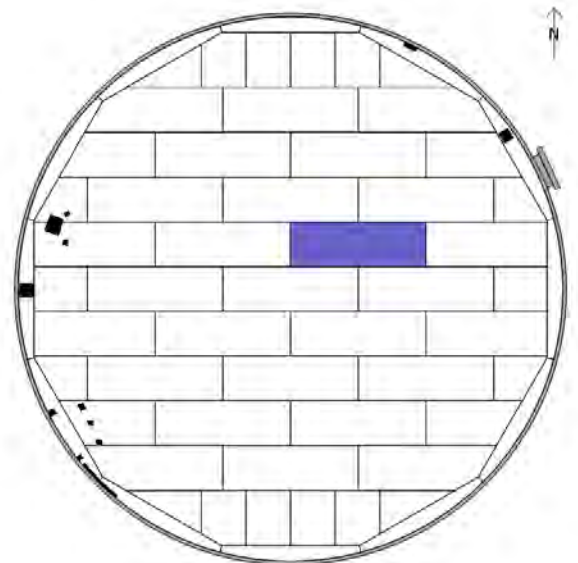
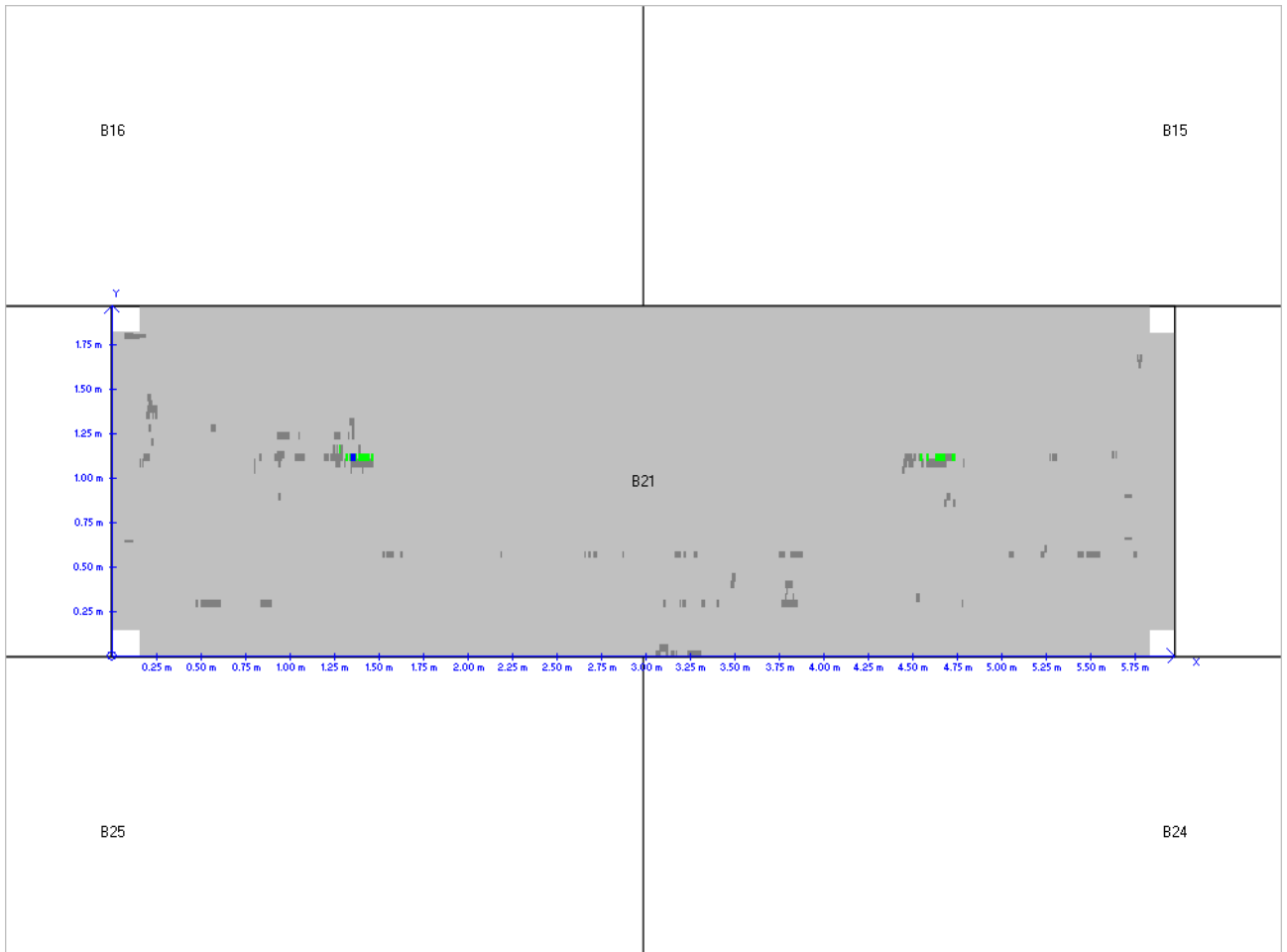

: Client a : Site b : 03/05/2016 : B 22	: Tank 123 : K0xx-16 : Jxx86
--	------------------------------------

Underside-Differential

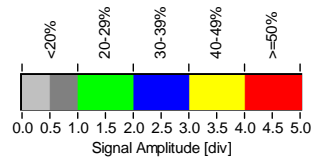
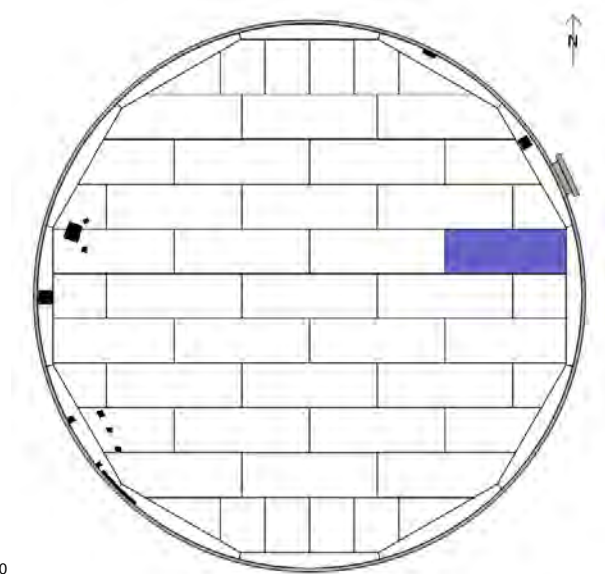
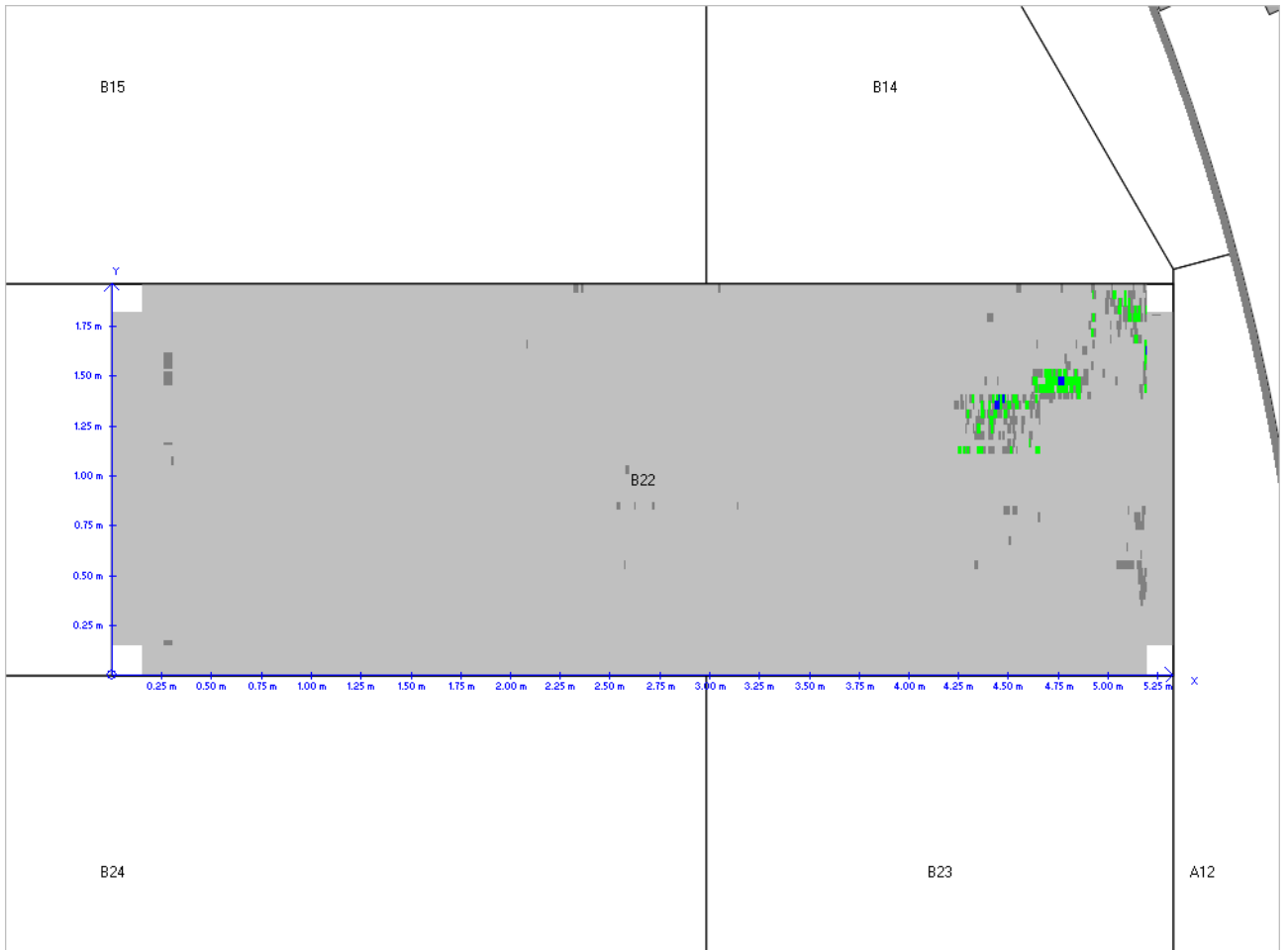

<ul style="list-style-type: none"> : Client a : Site b : 03/05/2016 : B 23 	<ul style="list-style-type: none"> : Tank 123 : K0xx-16 : Jxx86
--	--

Underside-Differential

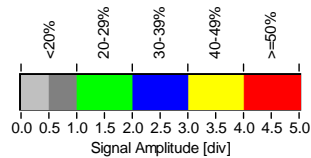
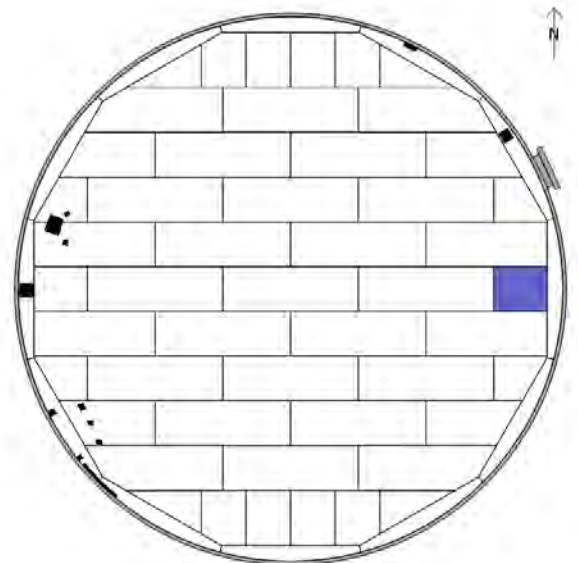
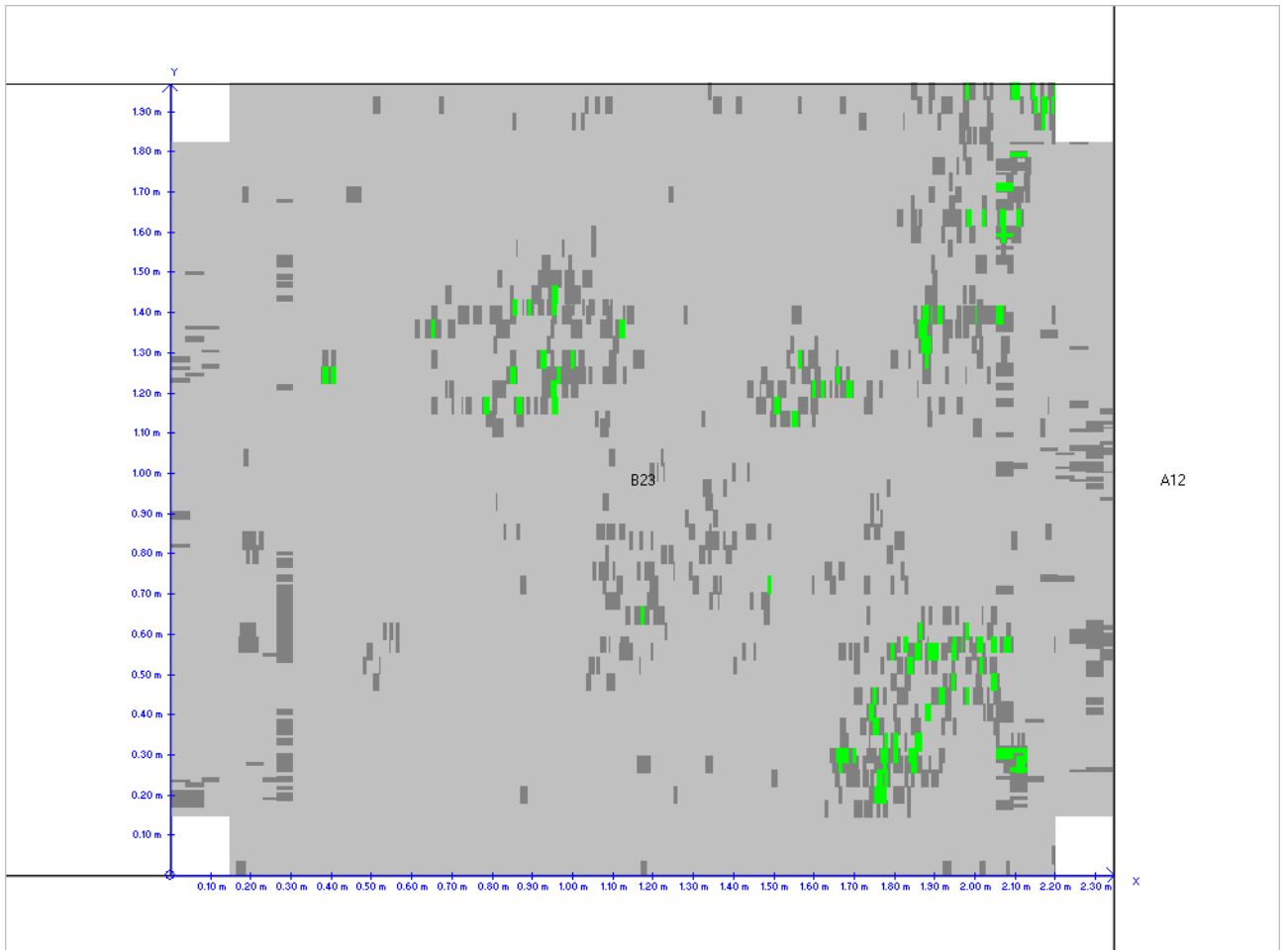

<ul style="list-style-type: none"> : Client a : Site b : 03/05/2016 : B 24 	<ul style="list-style-type: none"> : Tank 123 : K0xx-16 : Jxx86
--	--

Underside-Differential

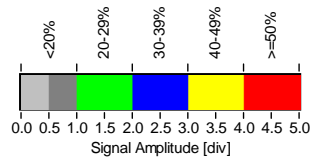
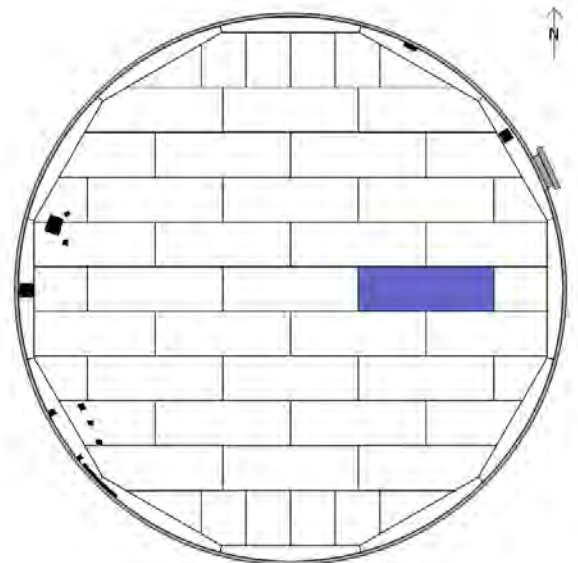
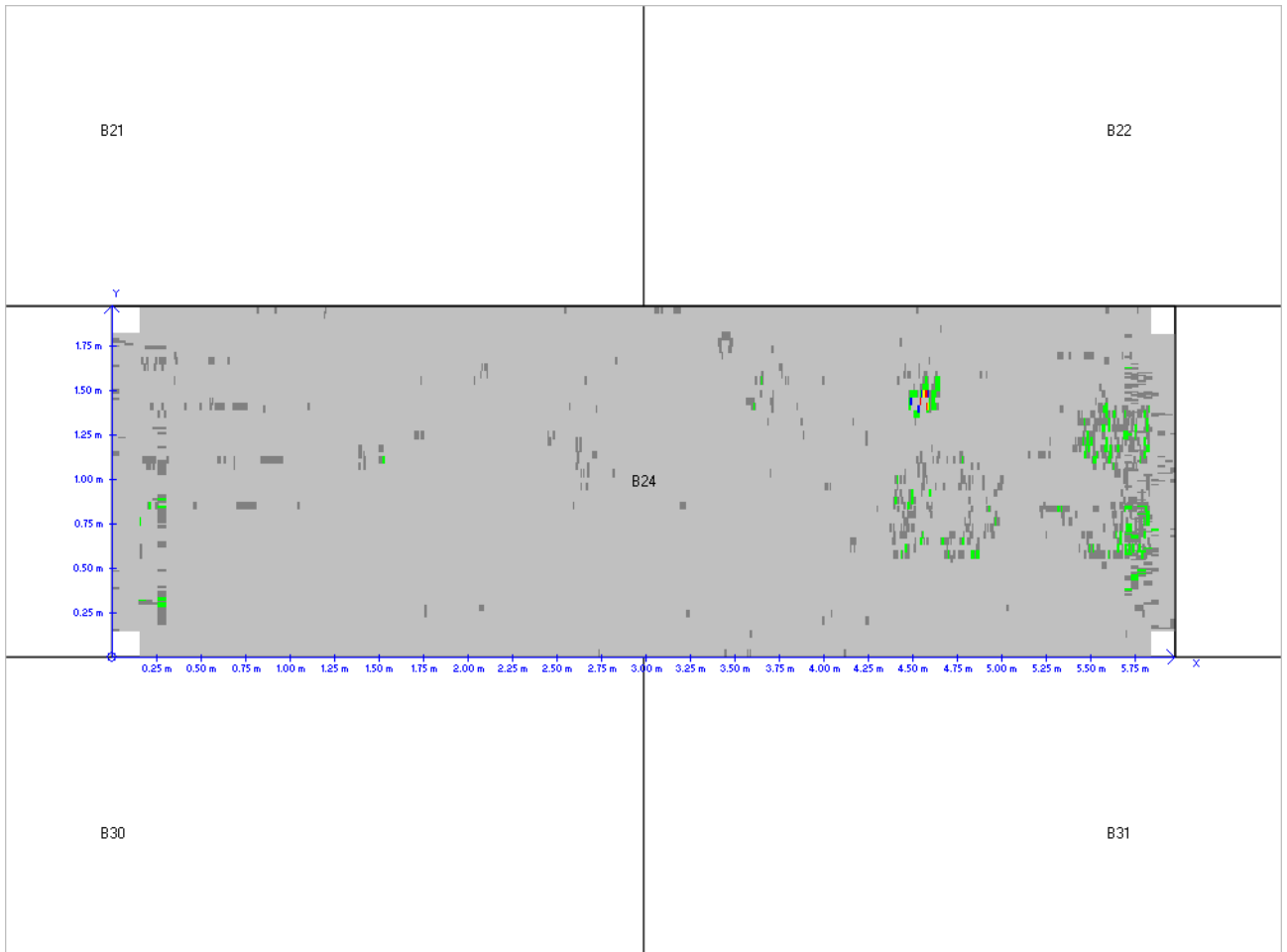

: Client a : Site b : 03/05/2016 : B 25	: Tank 123 : K0xx-16 : Jxx86
--	------------------------------------

Underside-Differential

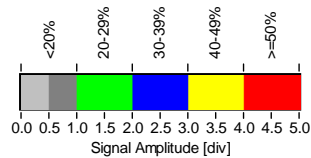
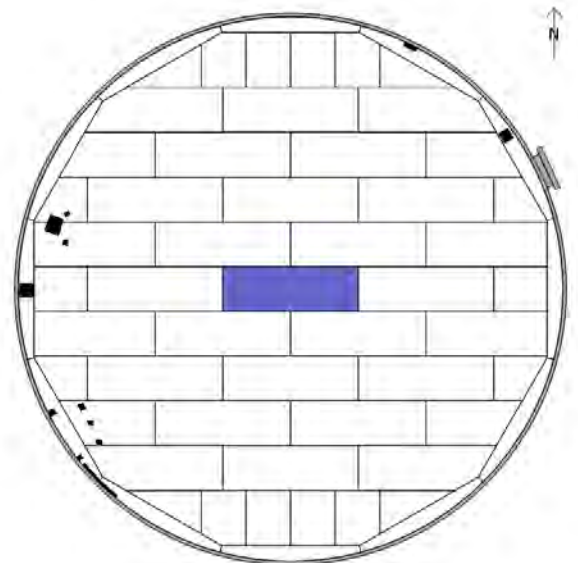
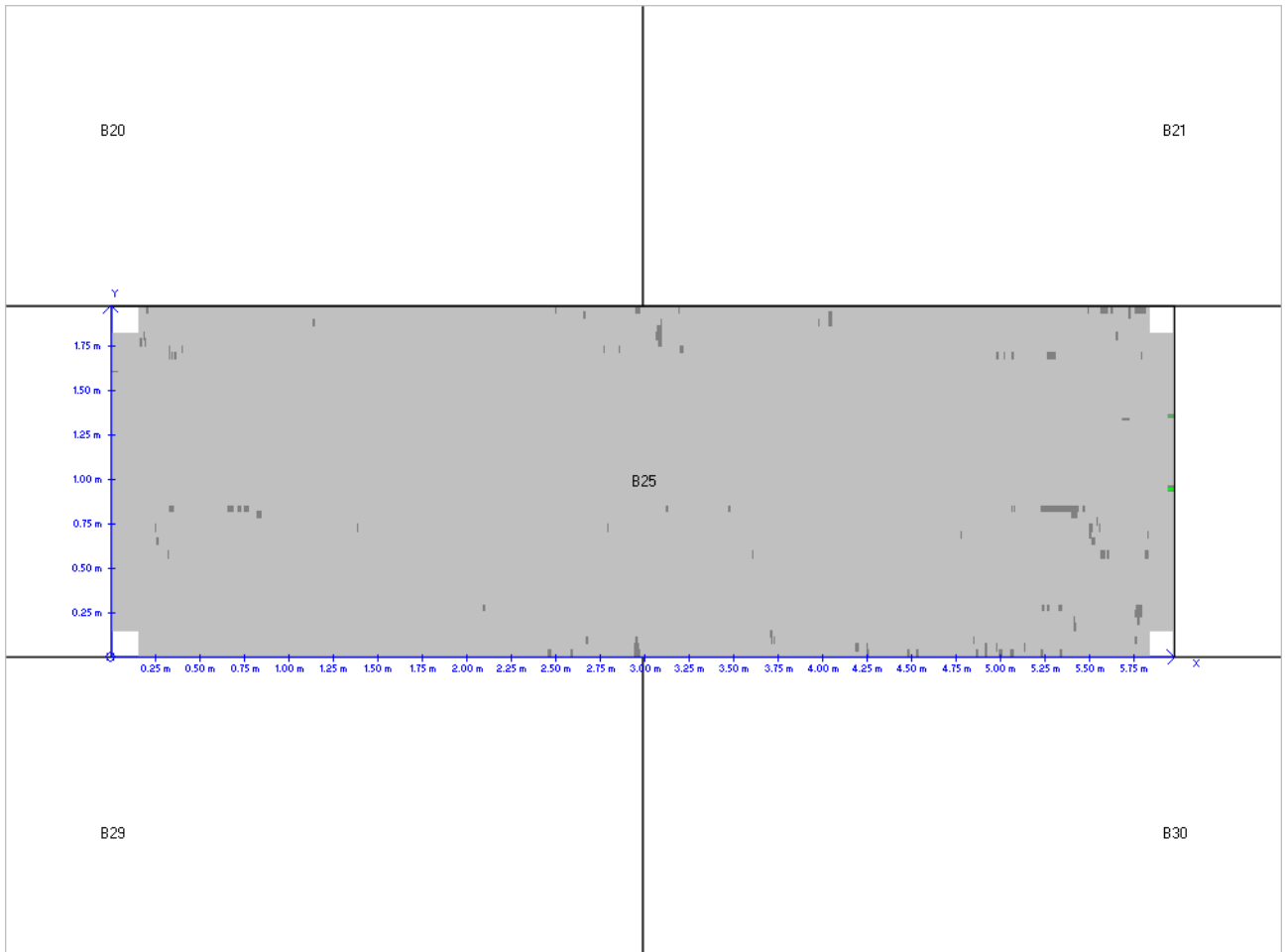

: Client a : Site b : 03/05/2016 : B 26	: Tank 123 : K0xx-16 : Jxx86
--	------------------------------------

Underside-Differential

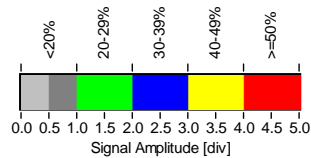
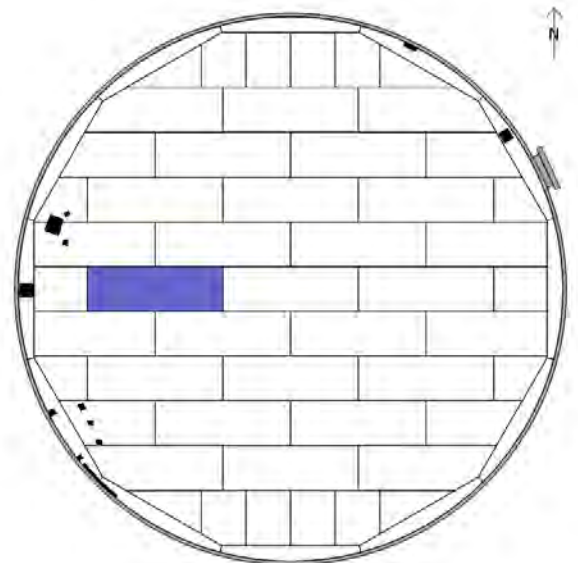
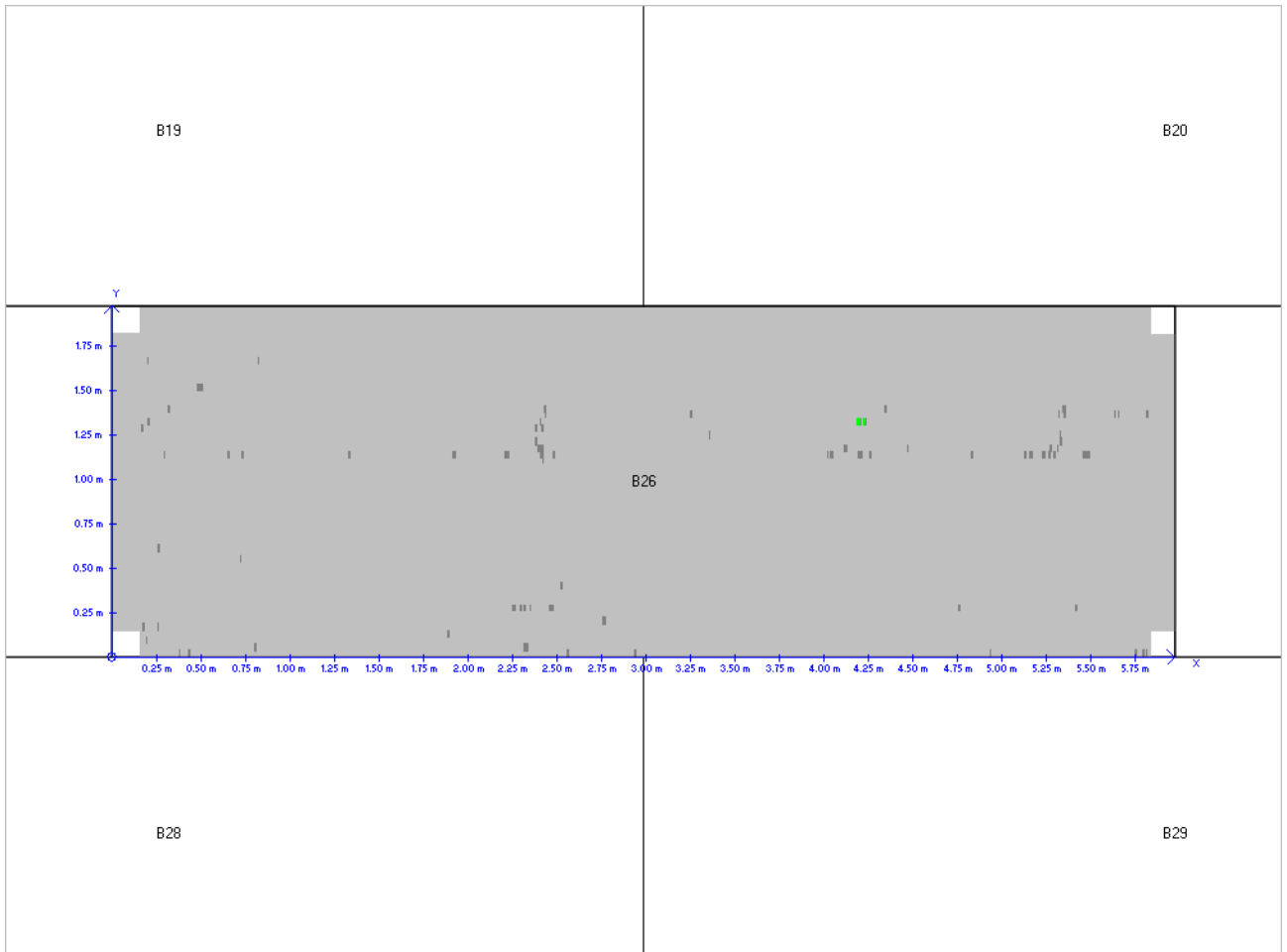

<ul style="list-style-type: none"> : Client a : Site b : 03/05/2016 : B 27 	<ul style="list-style-type: none"> : Tank 123 : K0xx-16 : Jxx86
--	--

Underside-Differential

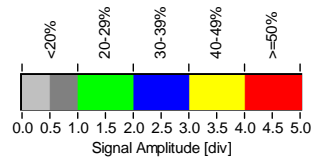
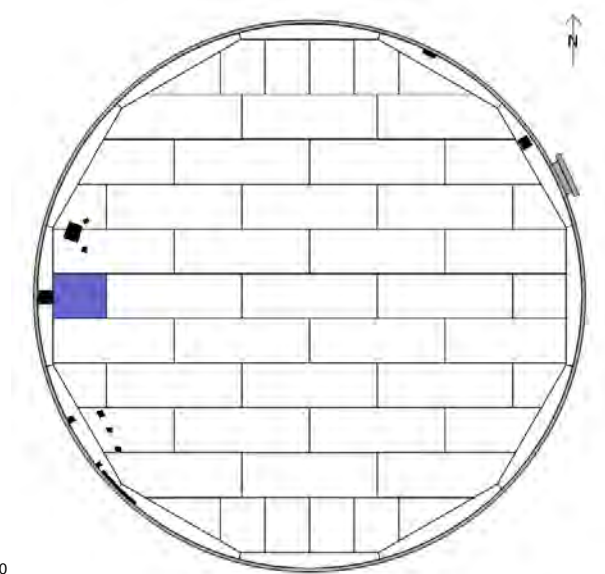
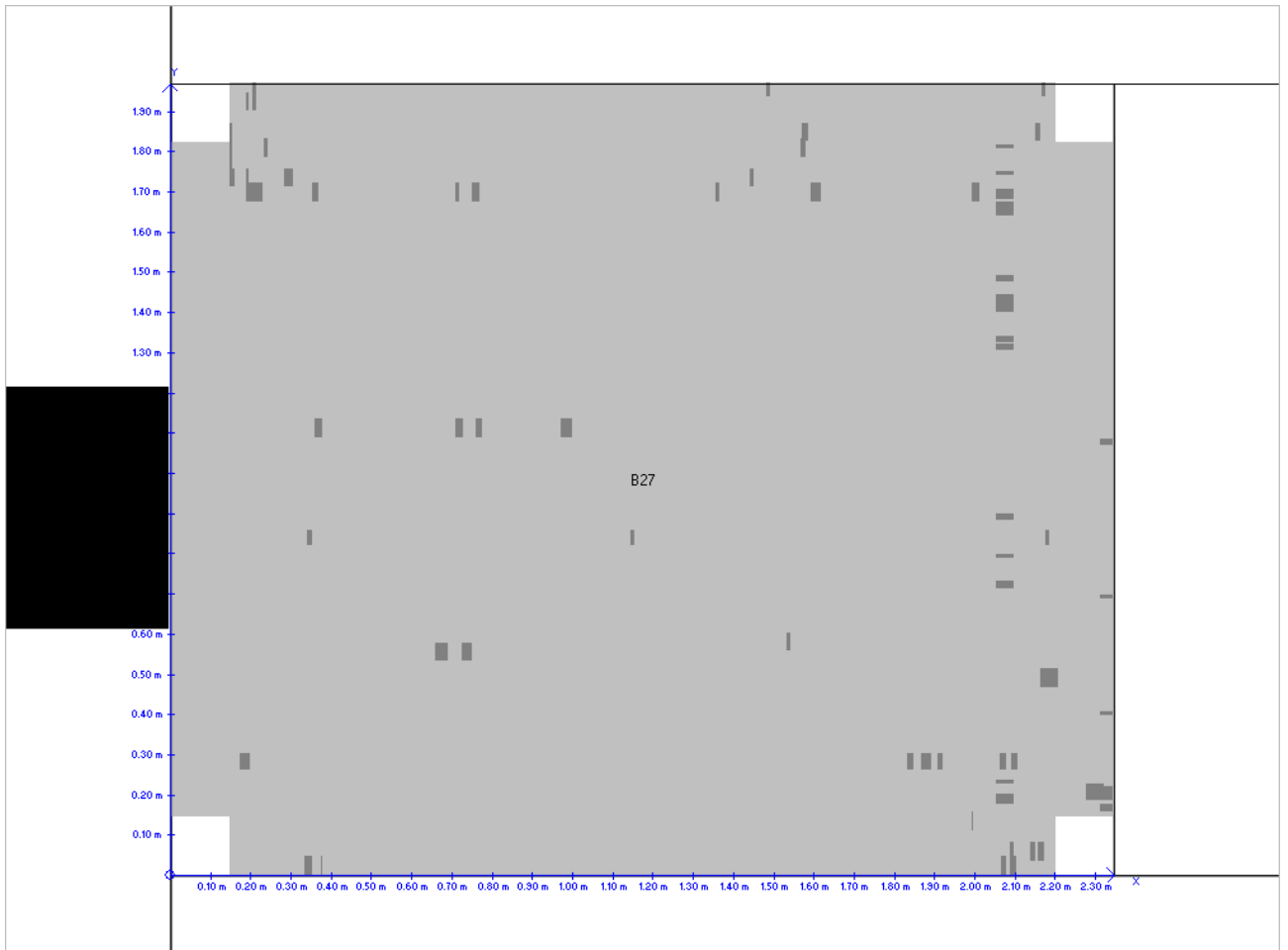

: Client x	: Tank 123
: Site b	: K0xx-16
: 03/05/2016	: Jxx86
: B 28	

Underside-Differential

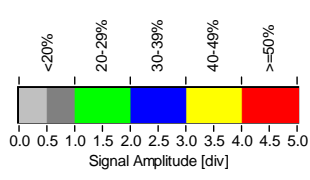
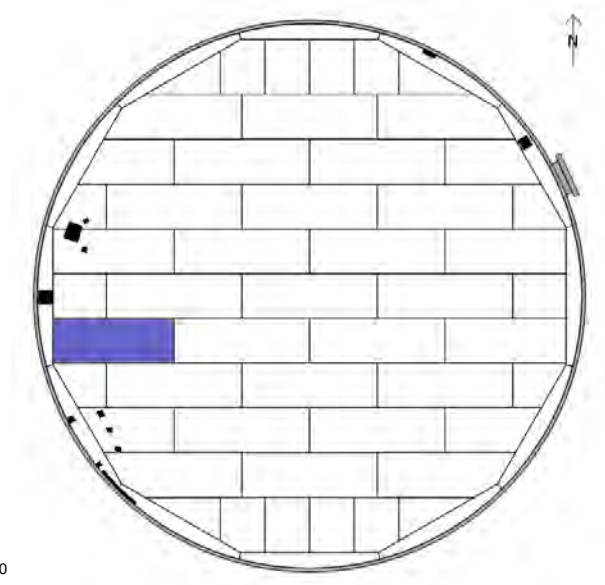
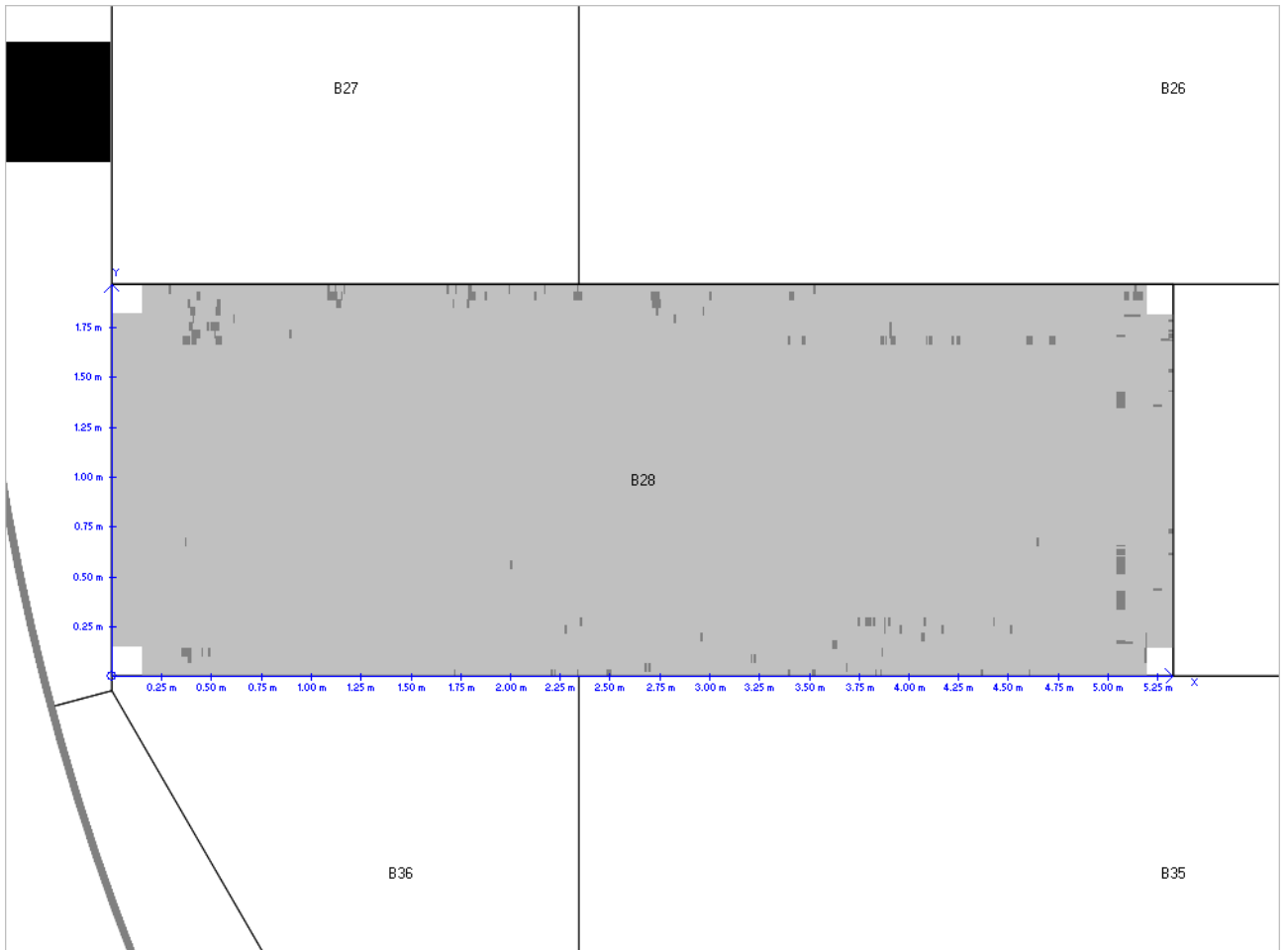

: Client a : Site b : 03/05/2016 : B 29	: Tank 123 : K0xx-16 : Jxx86
--	------------------------------------

Underside-Differential

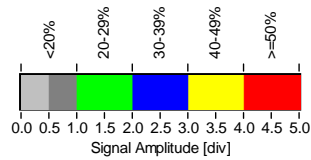
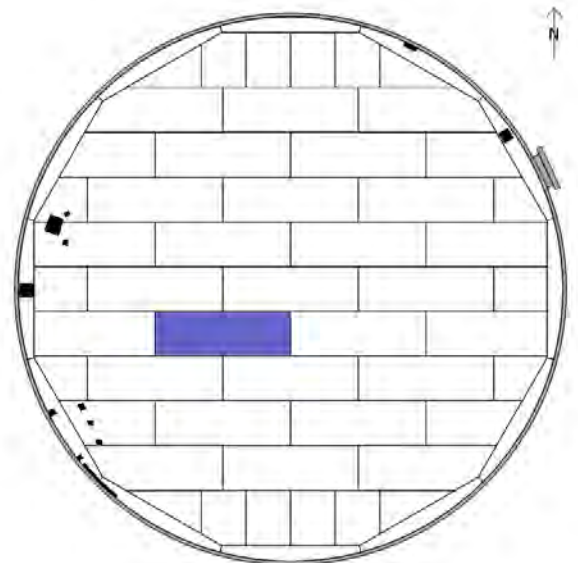
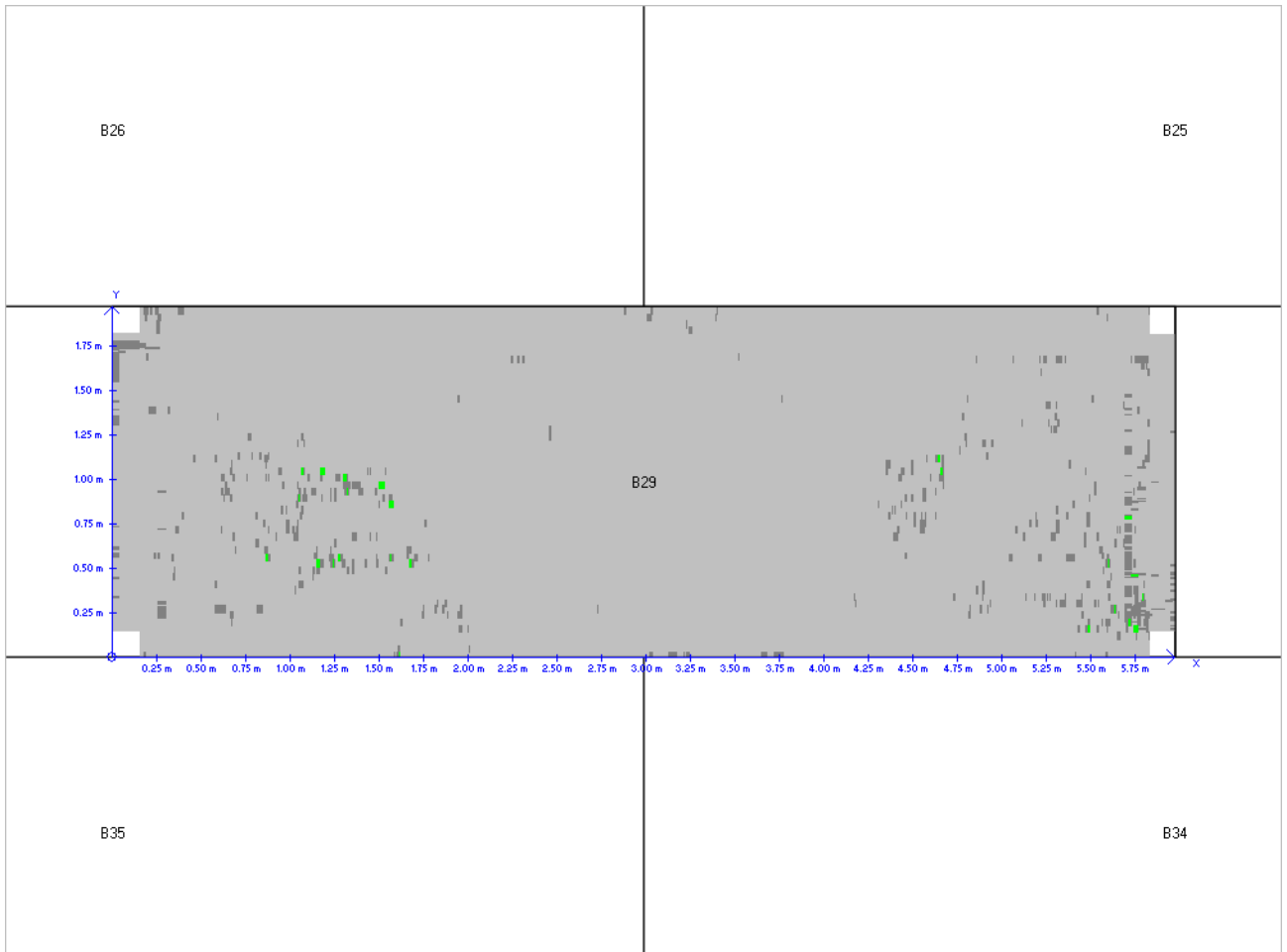

: Client a : Site b : 03/05/2016 : B 30	: Tank 123 : K0xx-16 : Jxx86
--	------------------------------------

Underside-Differential

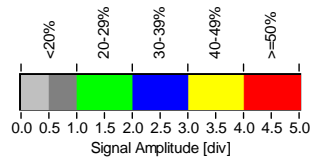
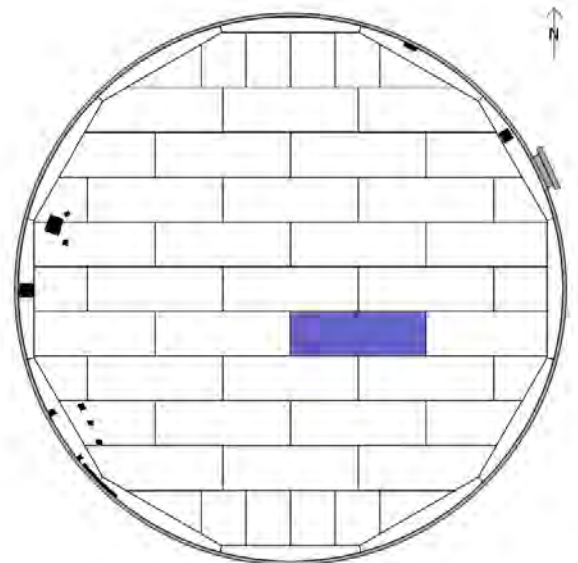
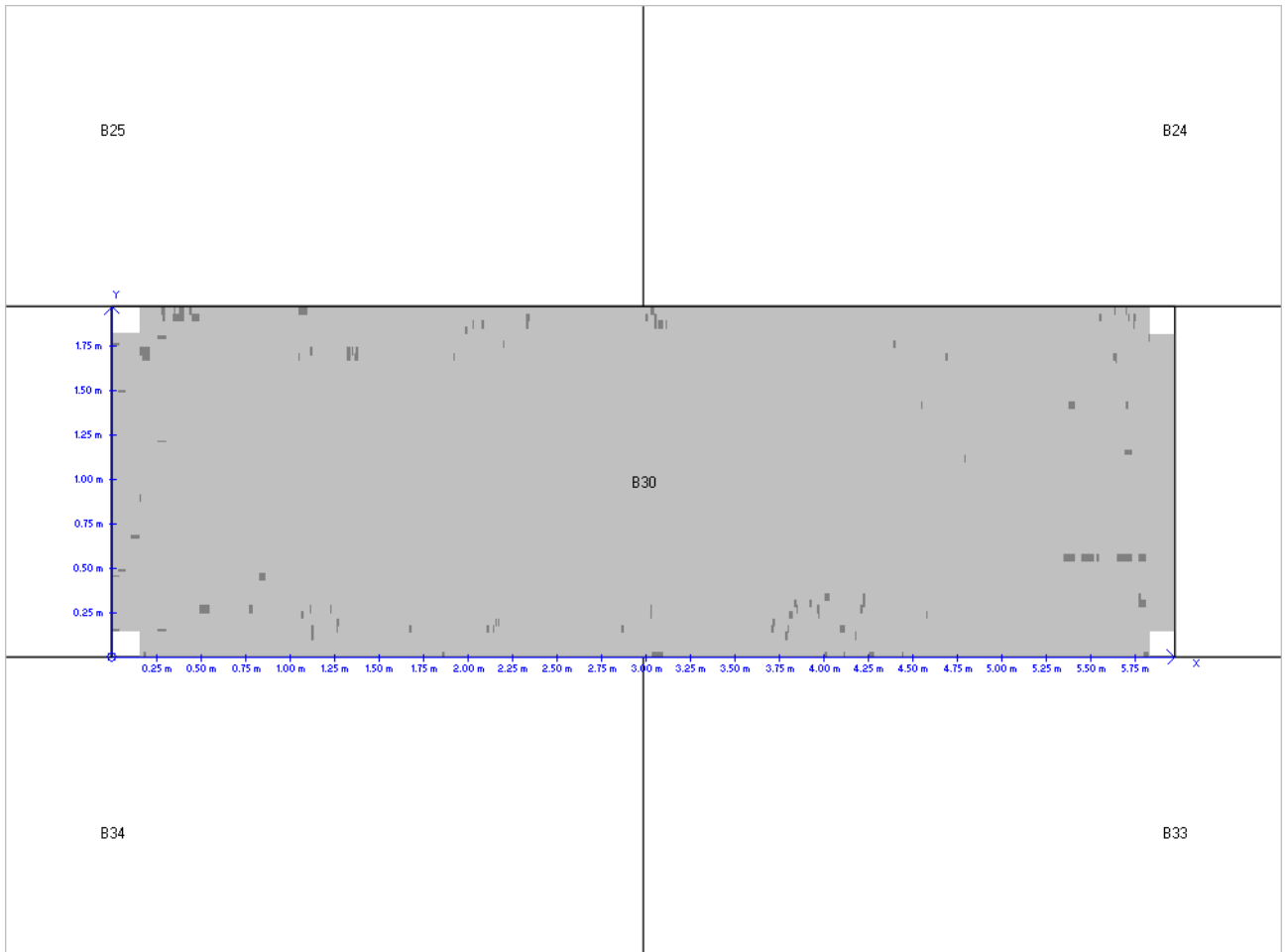

: Client a : Site b : 03/05/2016 : B 31	: Tank 123 : K0xx-16 : Jxx86
--	------------------------------------

Underside-Differential

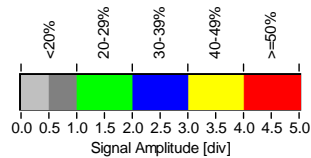
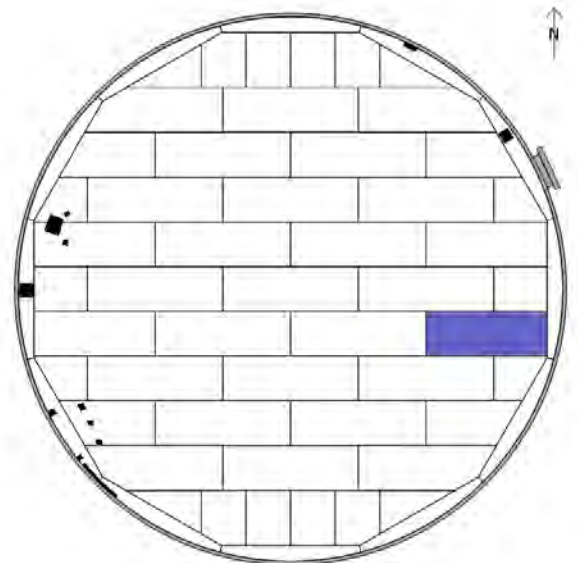
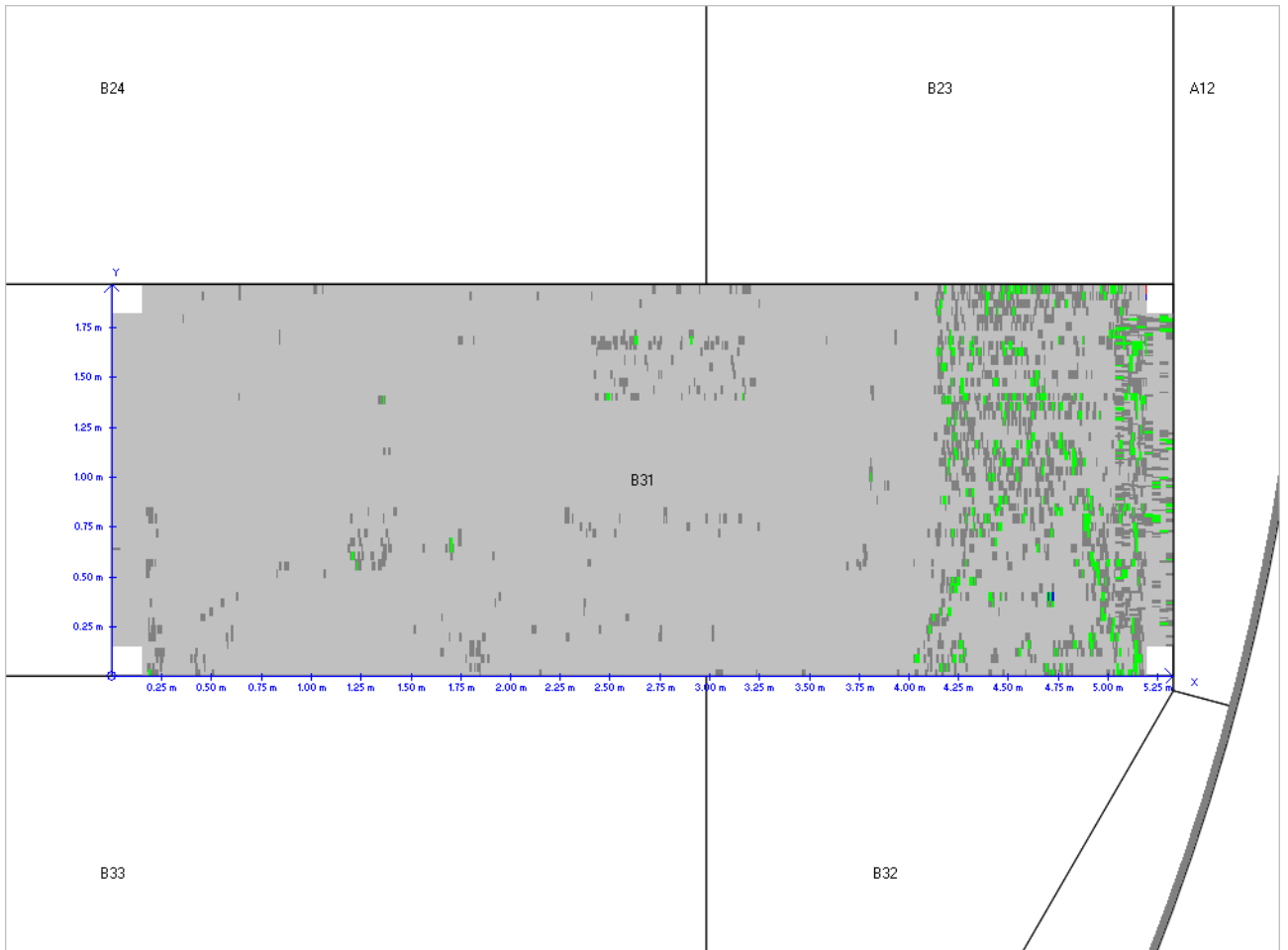

<ul style="list-style-type: none"> : Client a : Site b : 03/05/2016 : B 32 	<ul style="list-style-type: none"> : Tank 123 : K0xx-16 : Jxx86
--	--

Underside-Differential

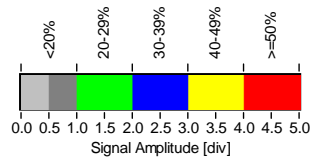
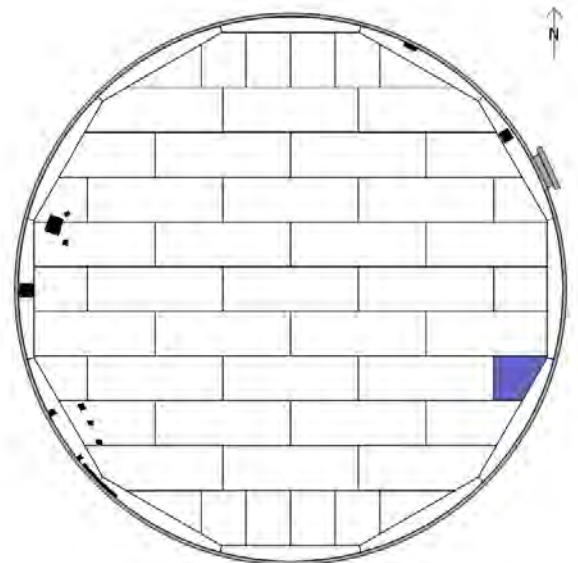
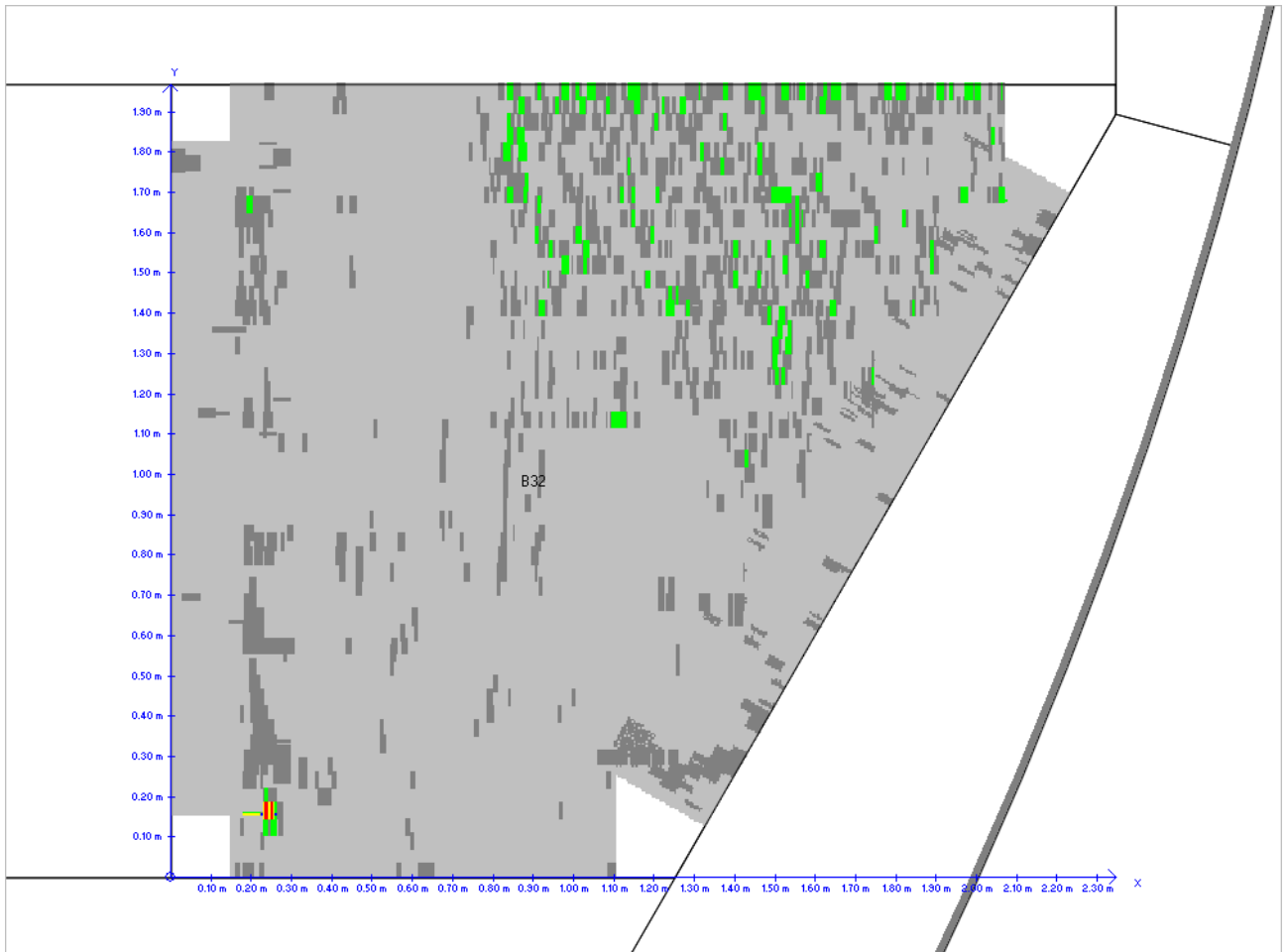

: Client a : Site b : 03/05/2016 : B 33	: Tank 123 : K0xx-16 : Jxx86
--	------------------------------------

Underside-Differential

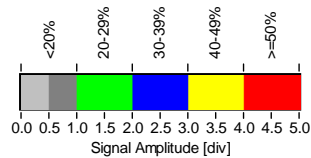
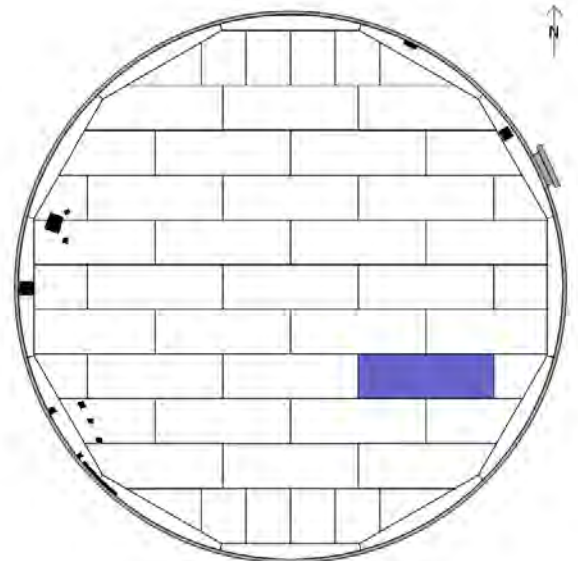
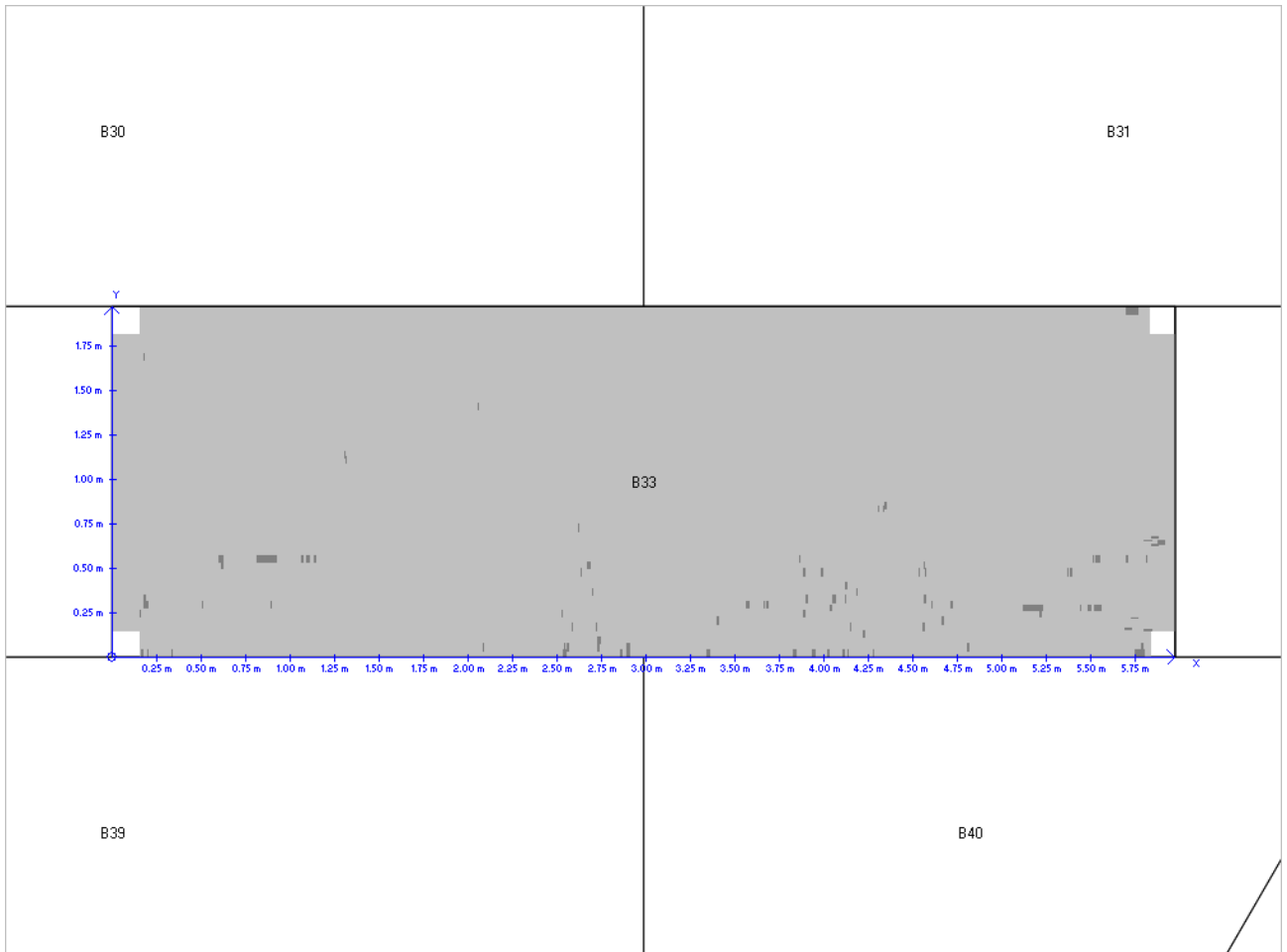

: Client a : Site b : 03/05/2016 : B 34	: Tank 123 : K0xx-16 : Jxx86
--	------------------------------------

Underside-Differential

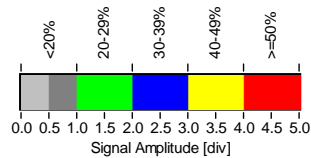
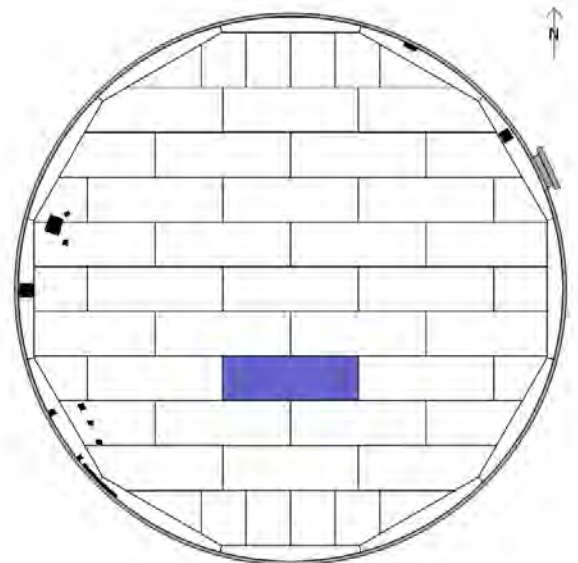
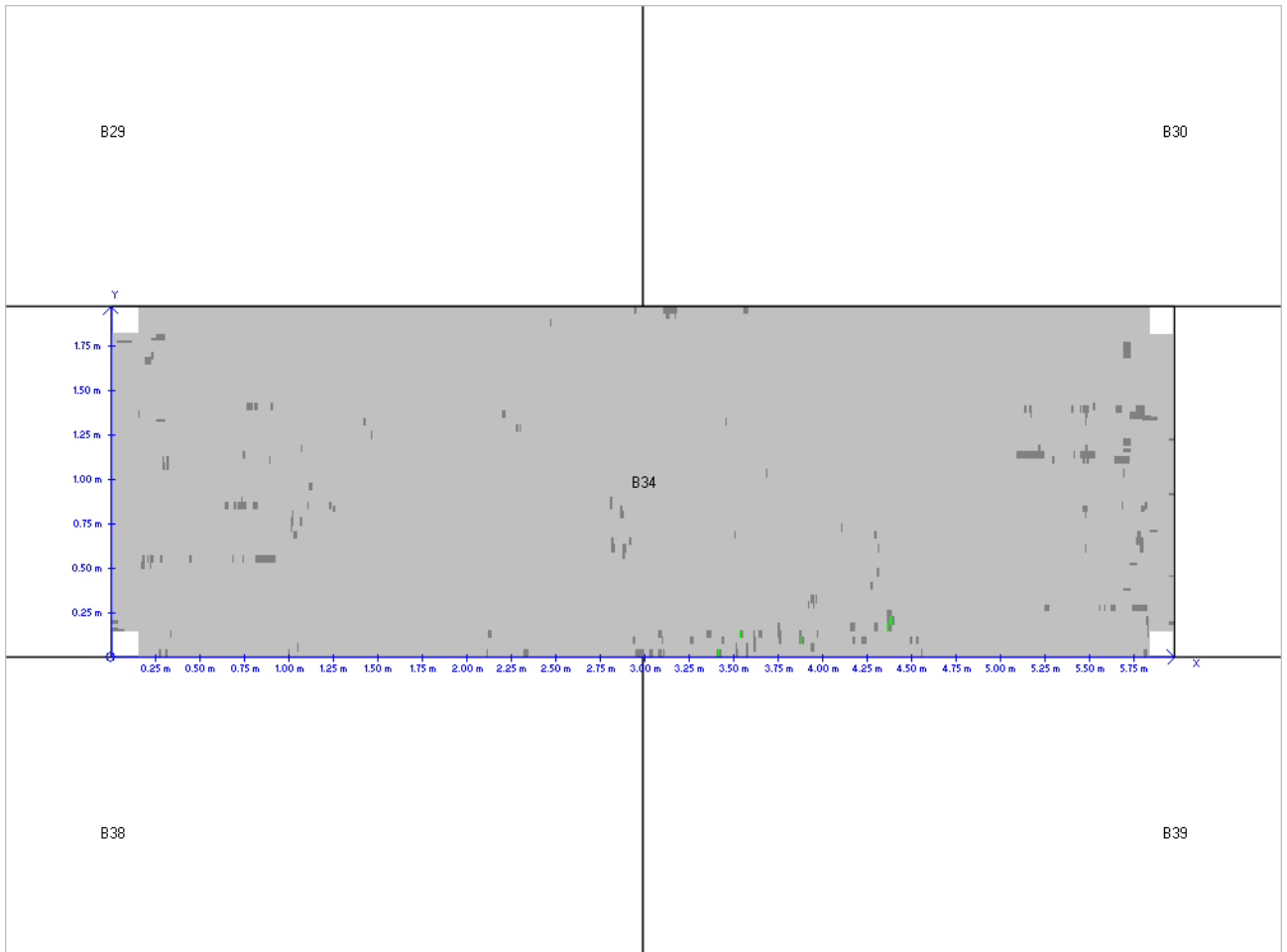

<ul style="list-style-type: none"> : Client a : Site b : 03/05/2016 : B 35 	<ul style="list-style-type: none"> : Tank 123 : K0xx-16 : Jxx86
--	--

Underside-Differential

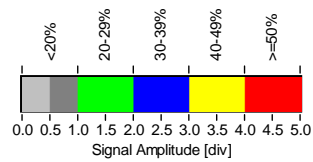
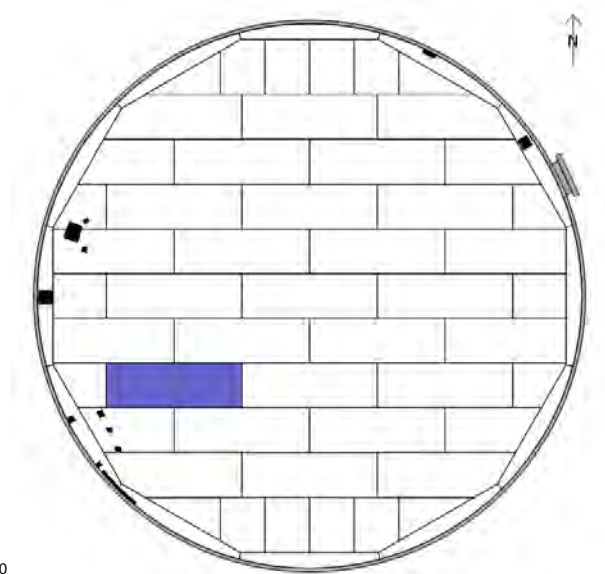
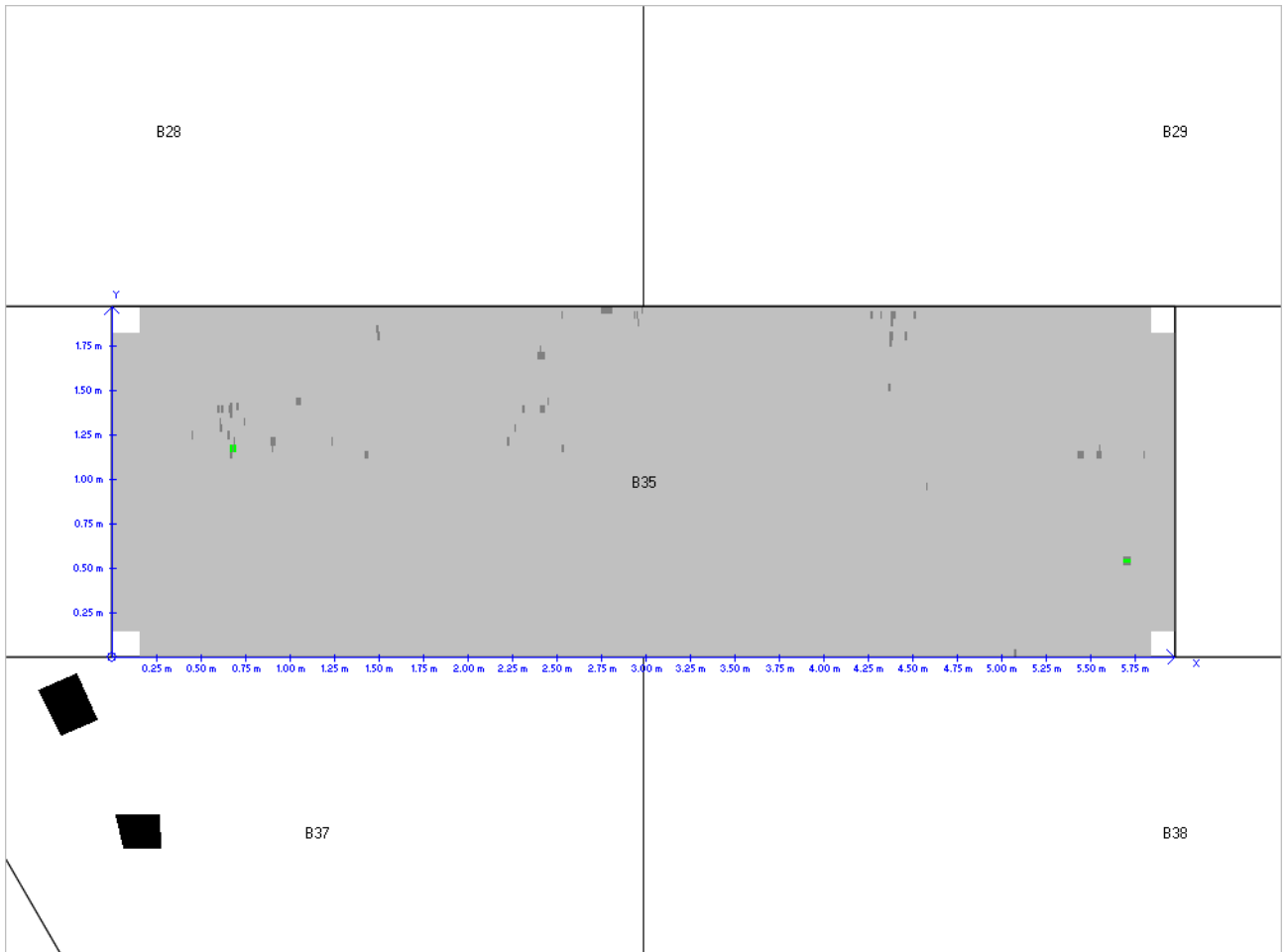

<ul style="list-style-type: none"> : Client a : Site b : 03/05/2016 : B 36 	<ul style="list-style-type: none"> : Tank 123 : K0xx-16 : Jxx86
--	--

Underside-Differential

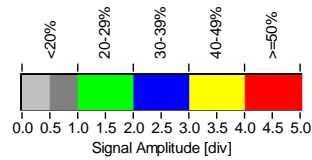
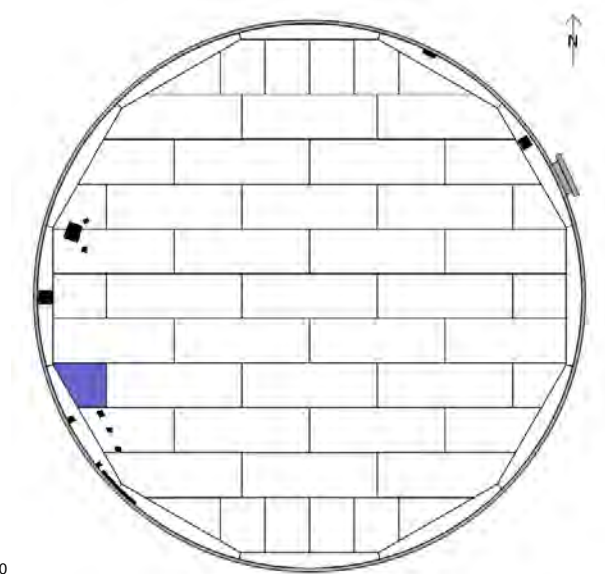
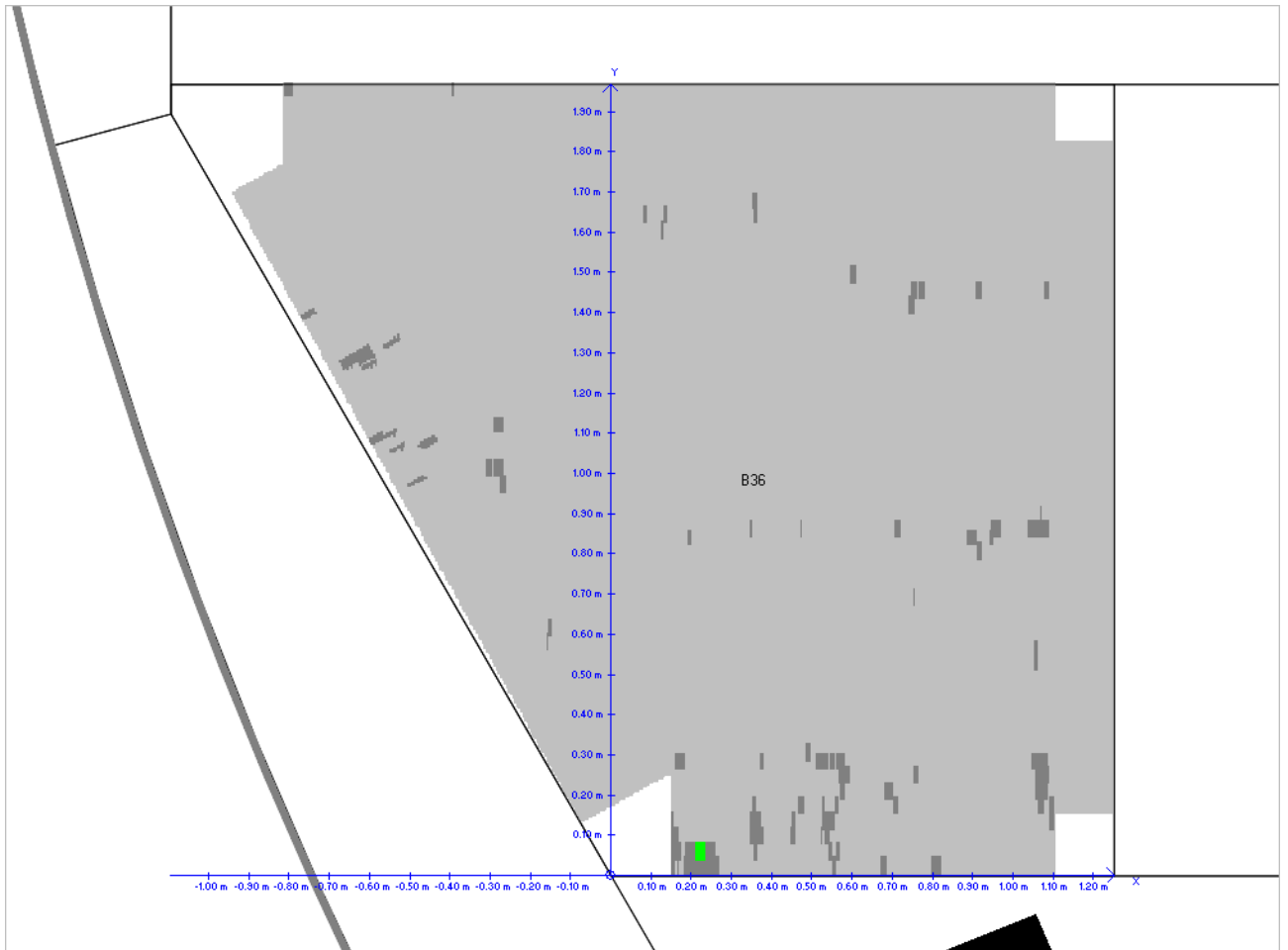

<ul style="list-style-type: none"> : Client a : Site b : 03/05/2016 : B 37 	<ul style="list-style-type: none"> : Tank 123 : K0xx-16 : Jxx86
--	--

Underside-Differential

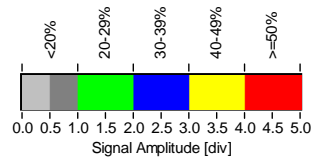
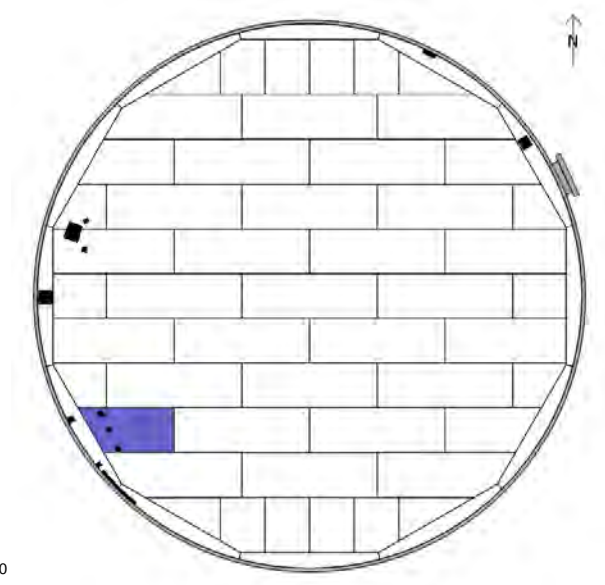
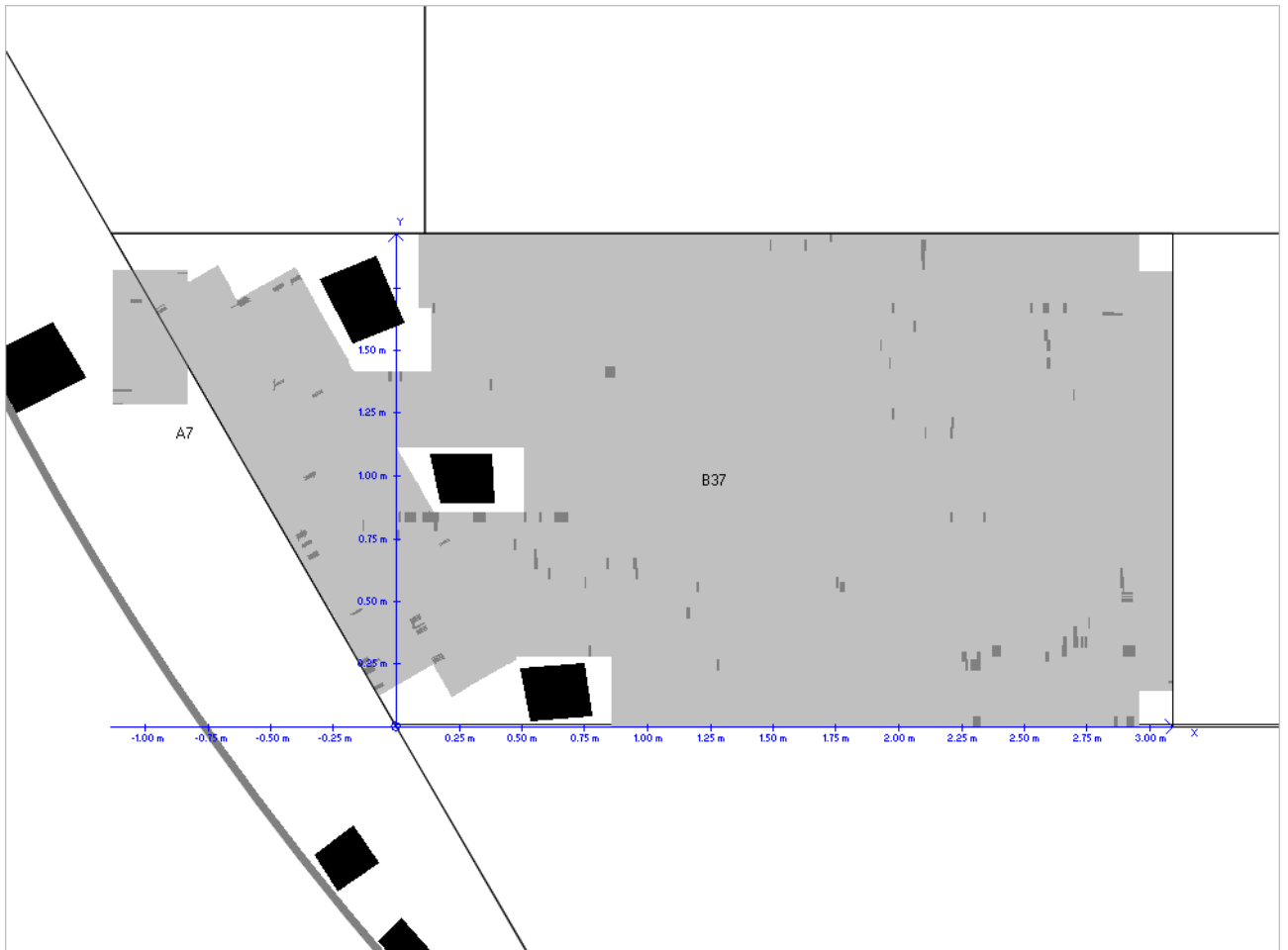

: Client a : Site b : 03/05/2016 : B 38	: Tank 123 : K0xx-16 : Jxx86
--	------------------------------------

Underside-Differential

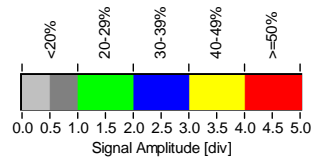
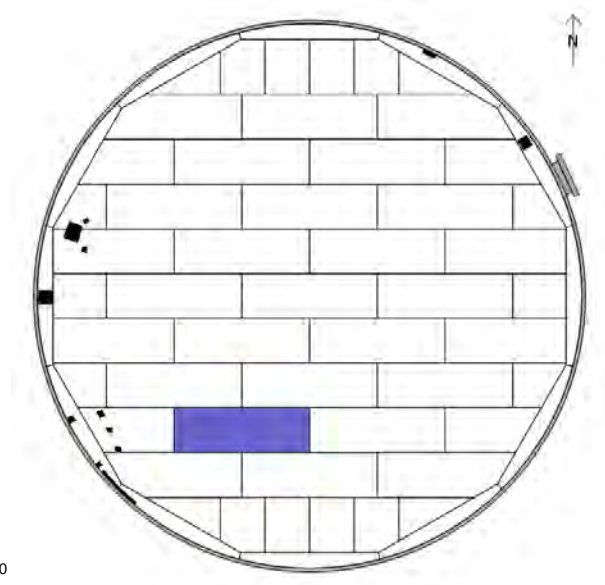
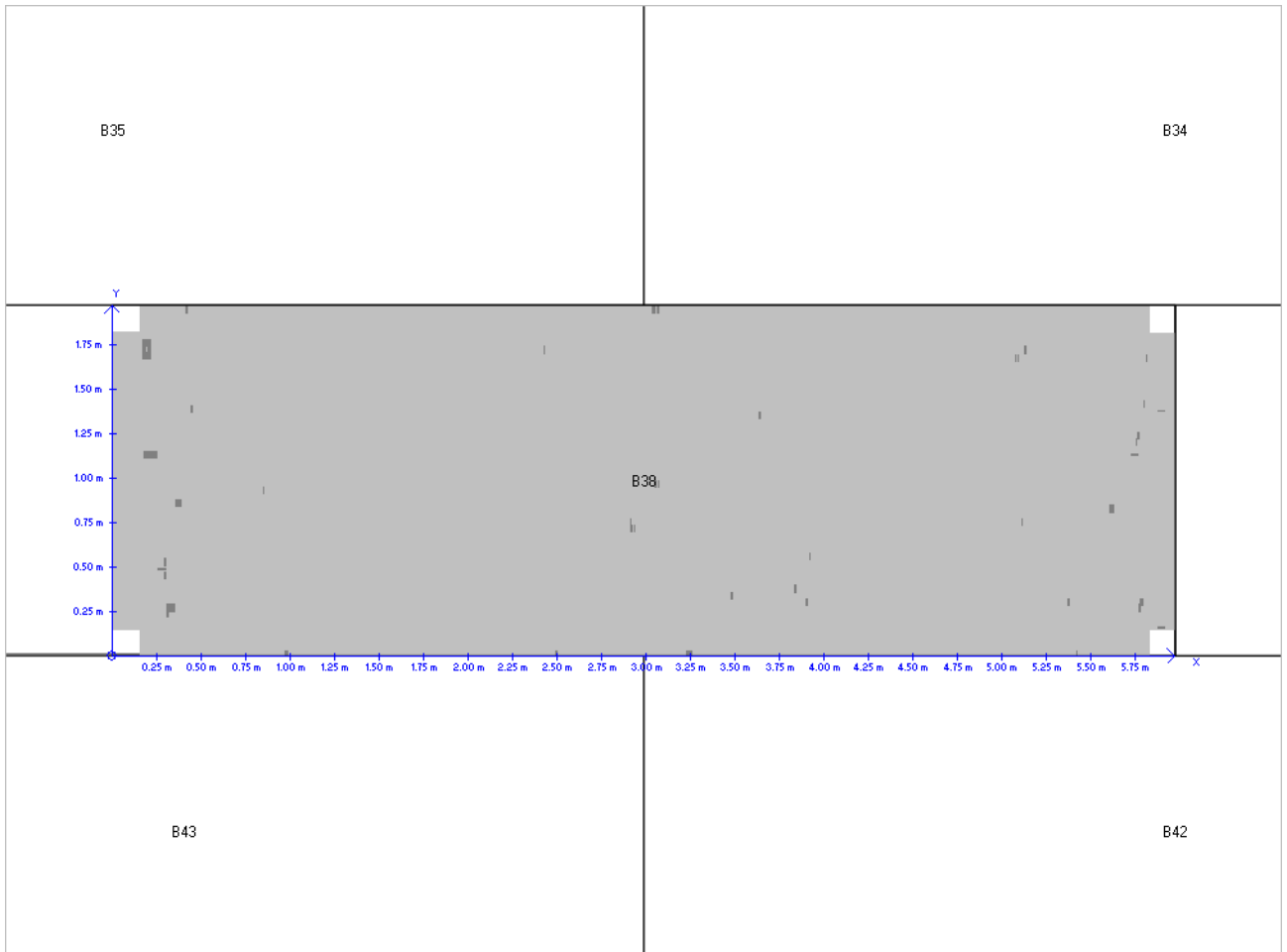

: Client a : Site b : 03/05/2016 : B 39	: Tank 123 : K0xx-16 : Jxx86
--	------------------------------------

Underside-Differential

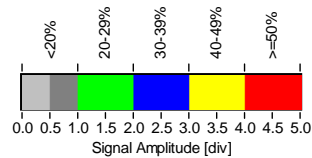
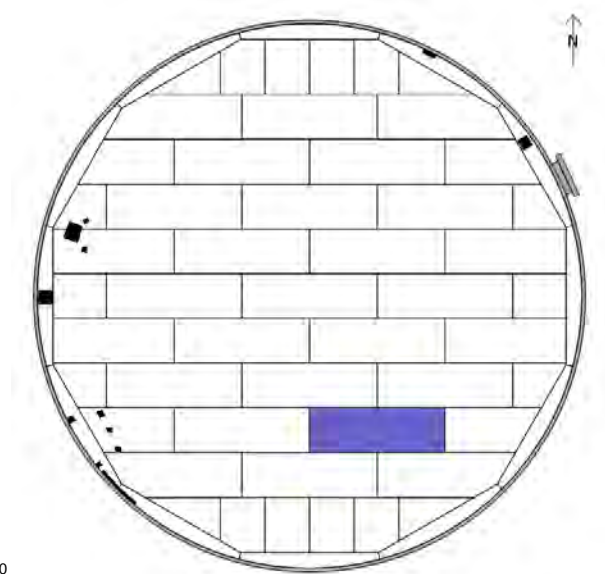
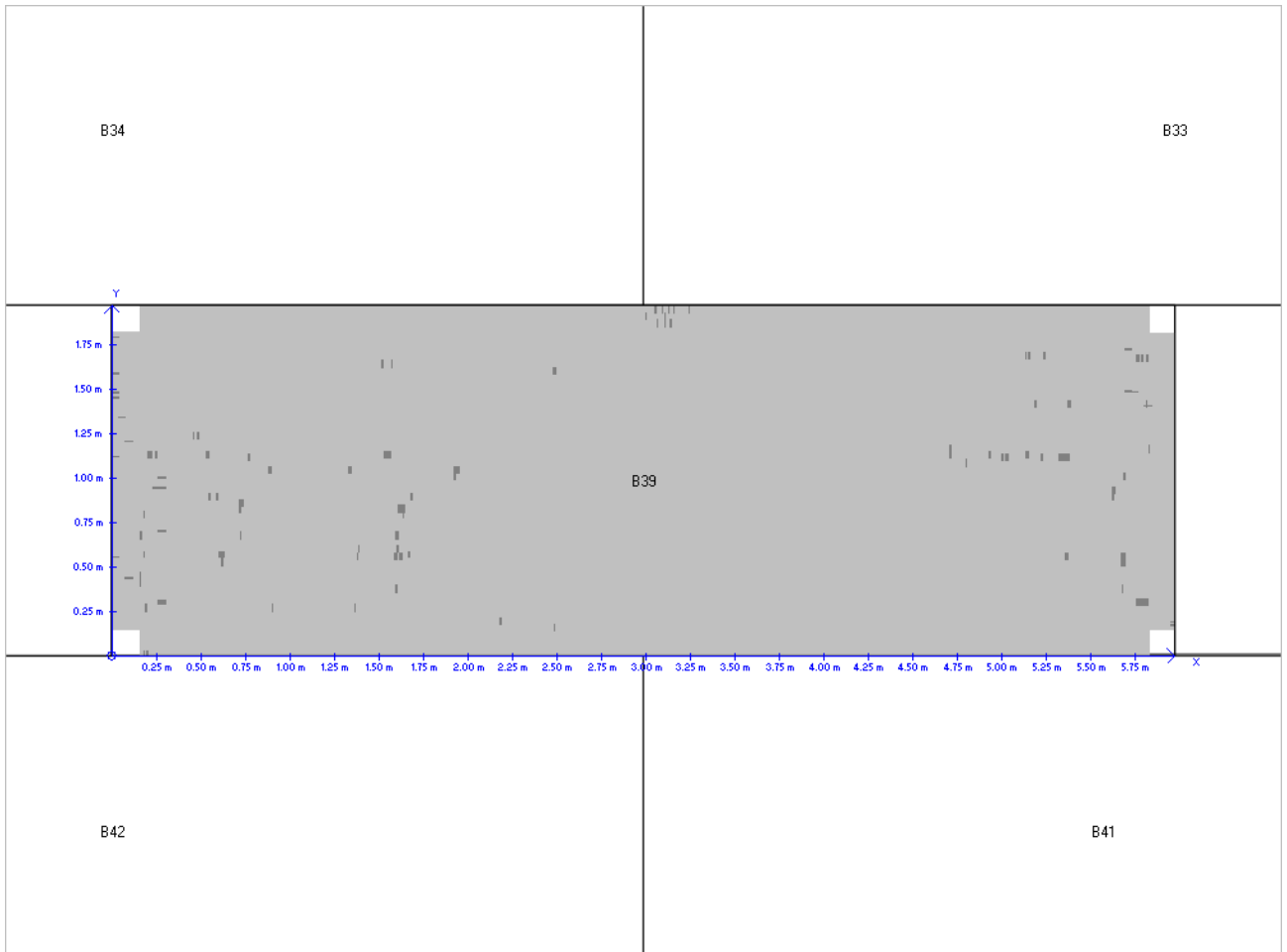

<ul style="list-style-type: none"> : Client a : Site b : 03/05/2016 : B 40 	<ul style="list-style-type: none"> : Tank 123 : K0xx-16 : Jxx86
--	--

Underside-Differential

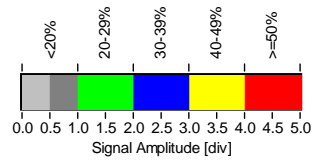
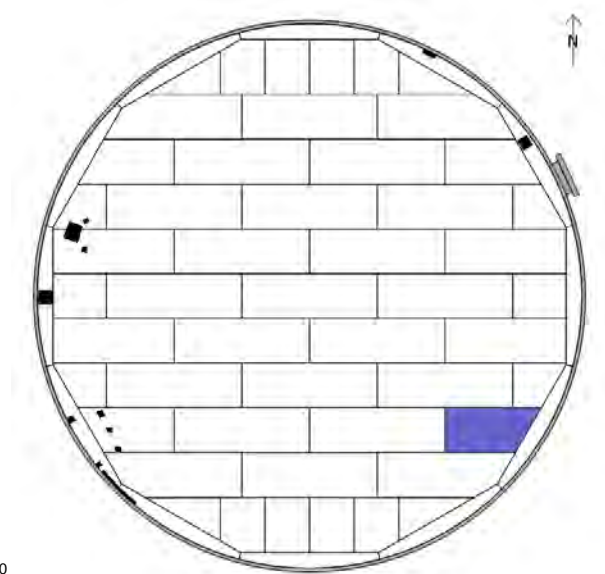
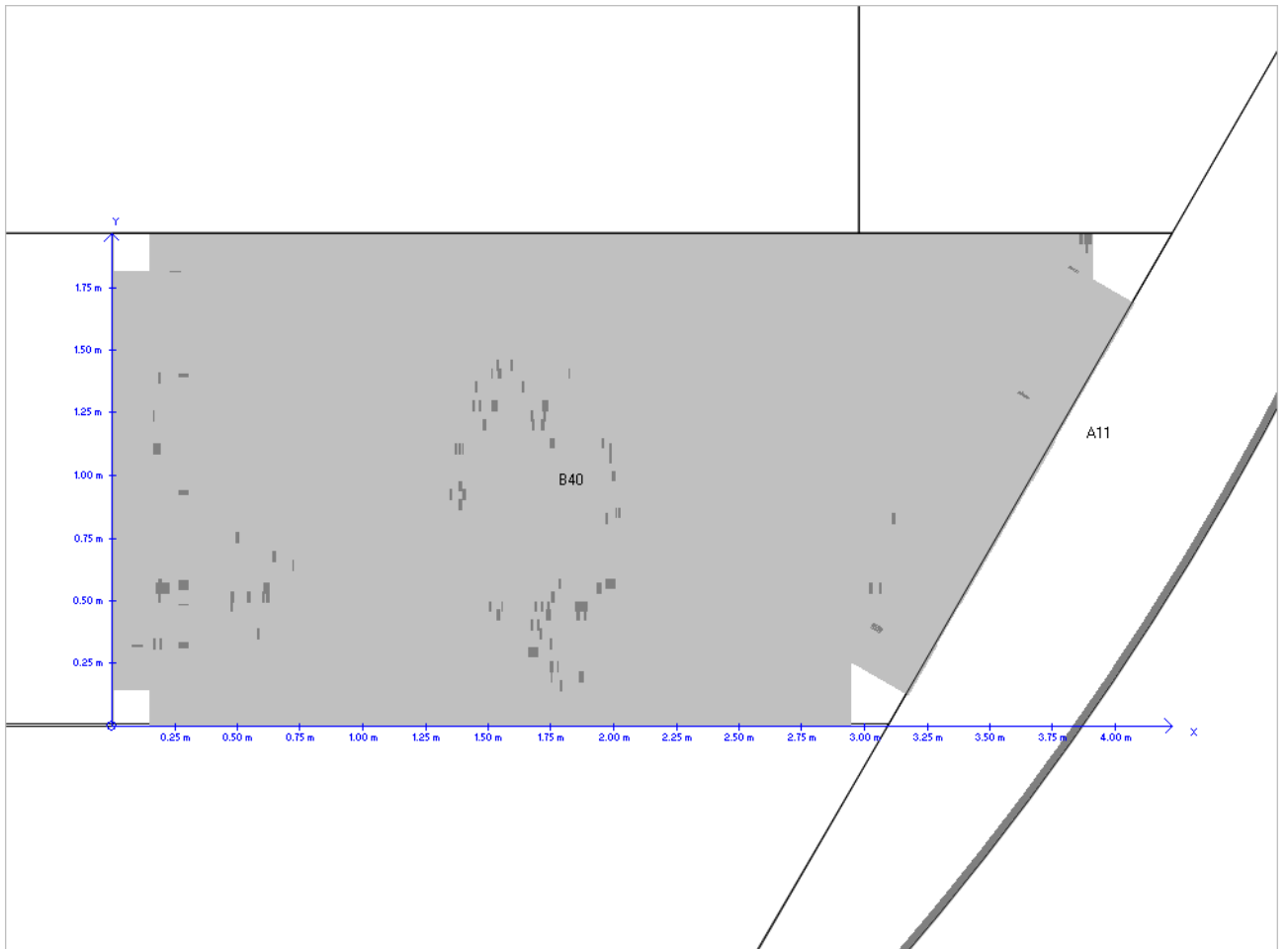

: Client : Site b : 03/05/2016 : B 41	: Tank 123 : K0xx-16 : Jxx86
--	------------------------------------

Underside-Differential

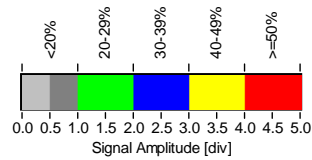
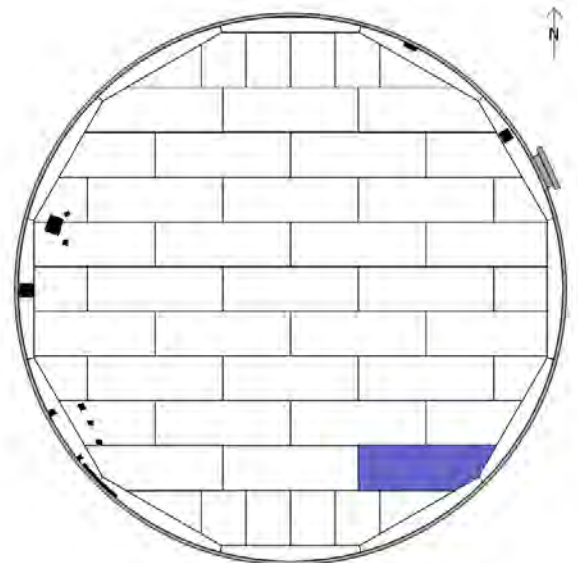
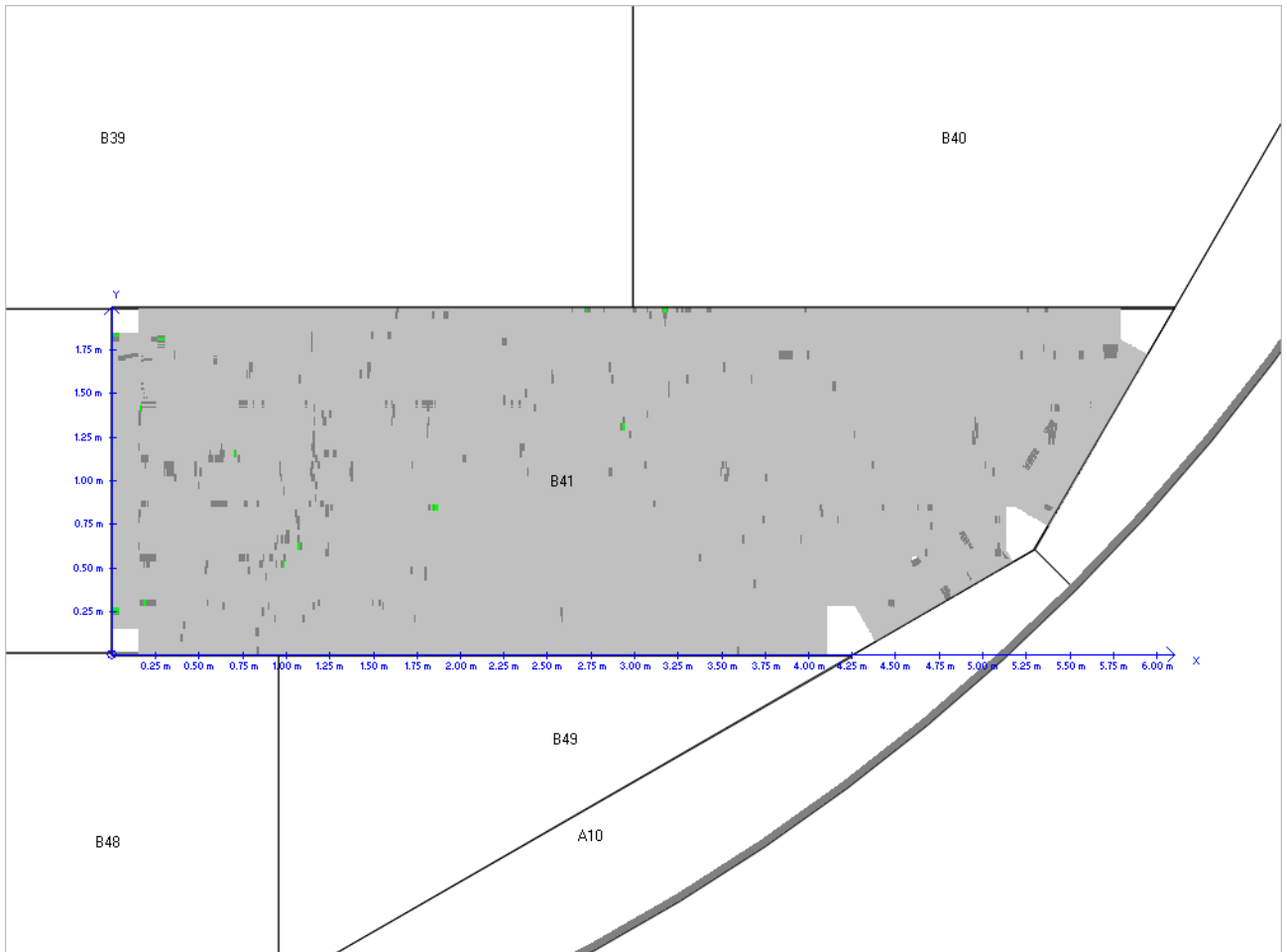

<ul style="list-style-type: none"> : Client a : Site b : 03/05/2016 : B 42 	<ul style="list-style-type: none"> : Tank 123 : K0xx-16 : Jxx86
--	--

Underside-Differential

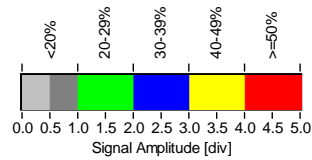
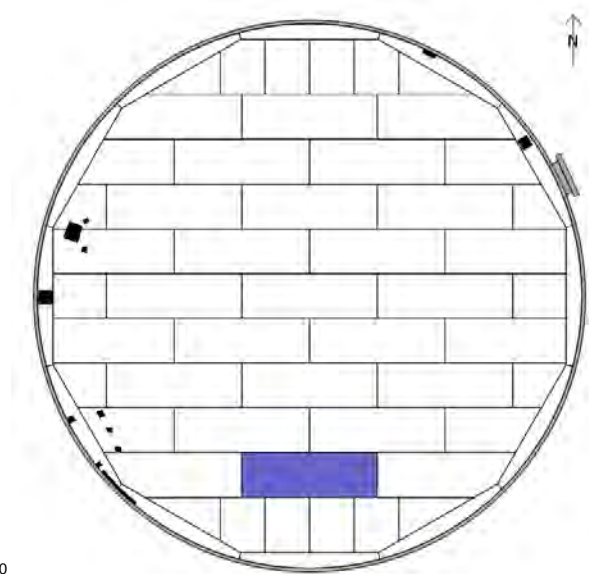
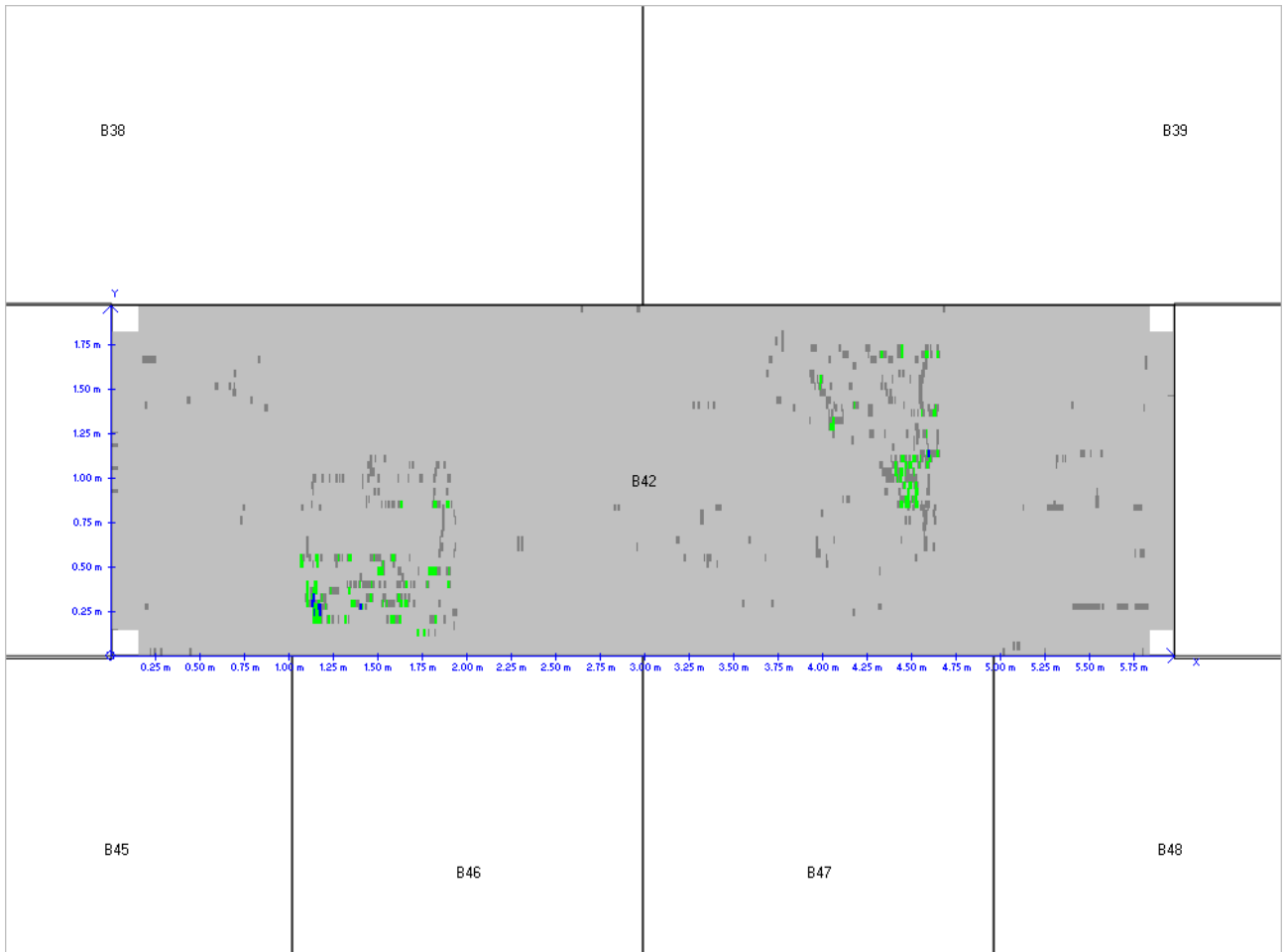

<ul style="list-style-type: none"> : Client a : Site b : 03/05/2016 : B 43 	<ul style="list-style-type: none"> : Tank 123 : K0xx-16 : Jxx86
--	--

Underside-Differential

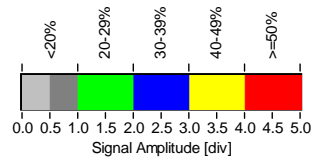
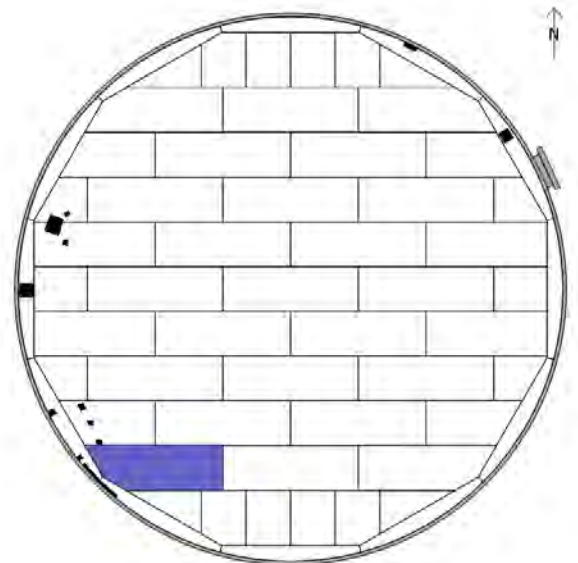
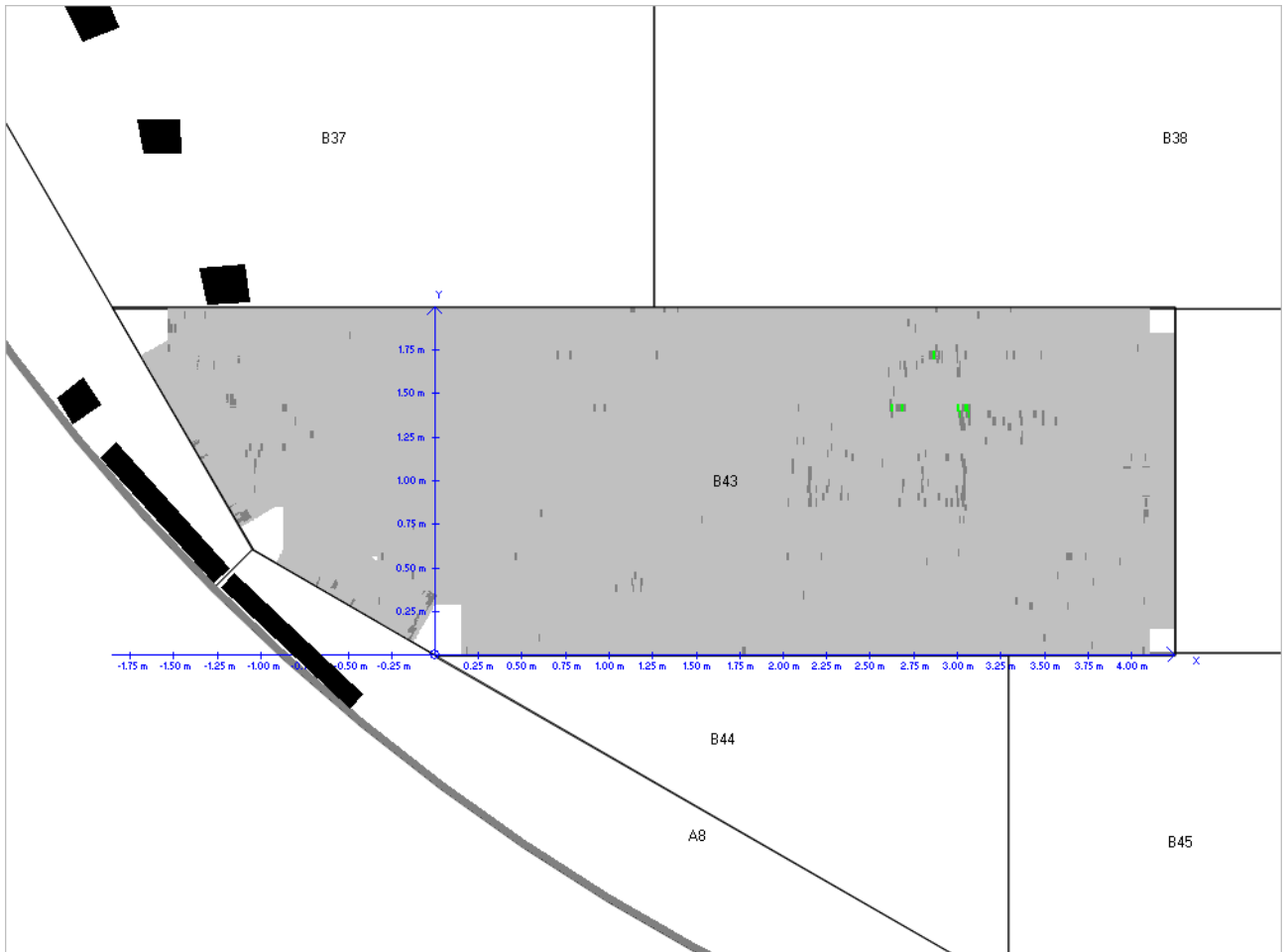

<ul style="list-style-type: none"> : Client a : Site b : 03/05/2016 : B 44 	<ul style="list-style-type: none"> : Tank 123 : K0xx-16 : Jxx86
--	--

Underside-Differential

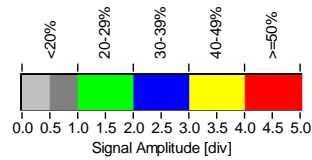
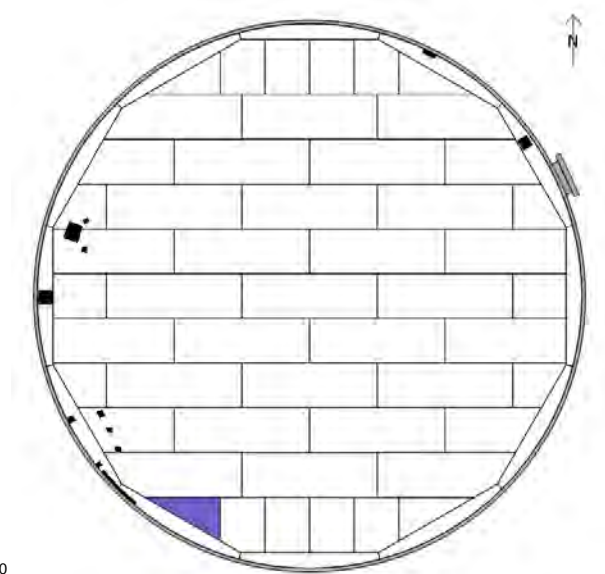
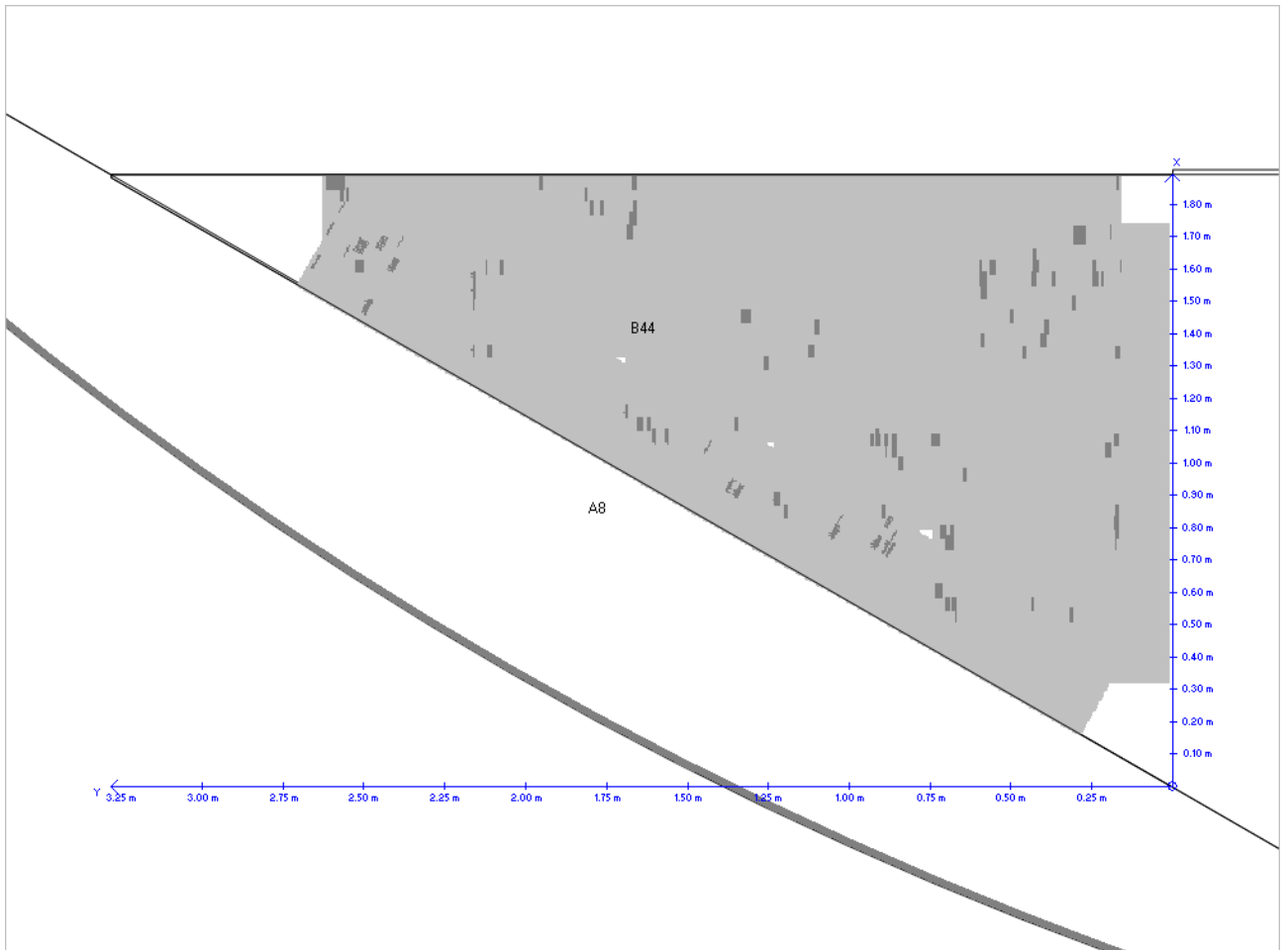

<ul style="list-style-type: none"> : Client a : Site b : 03/05/2016 : B 45 	<ul style="list-style-type: none"> : Tank 123 : K0xx-16 : Jxx86
--	--

Underside-Differential

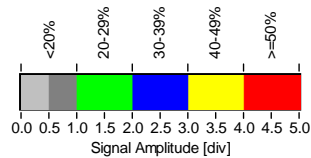
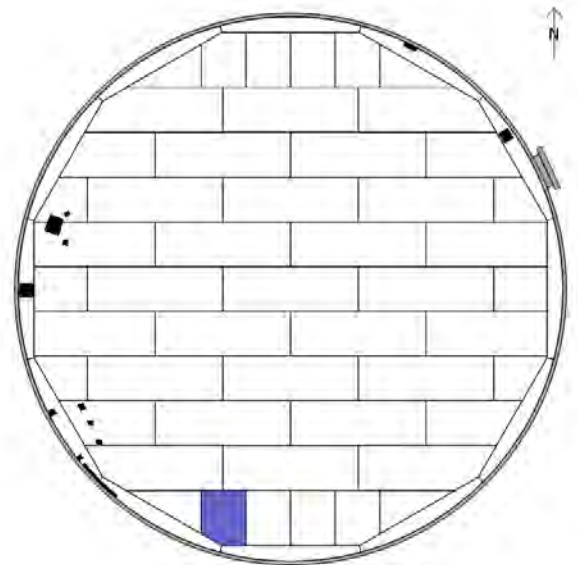
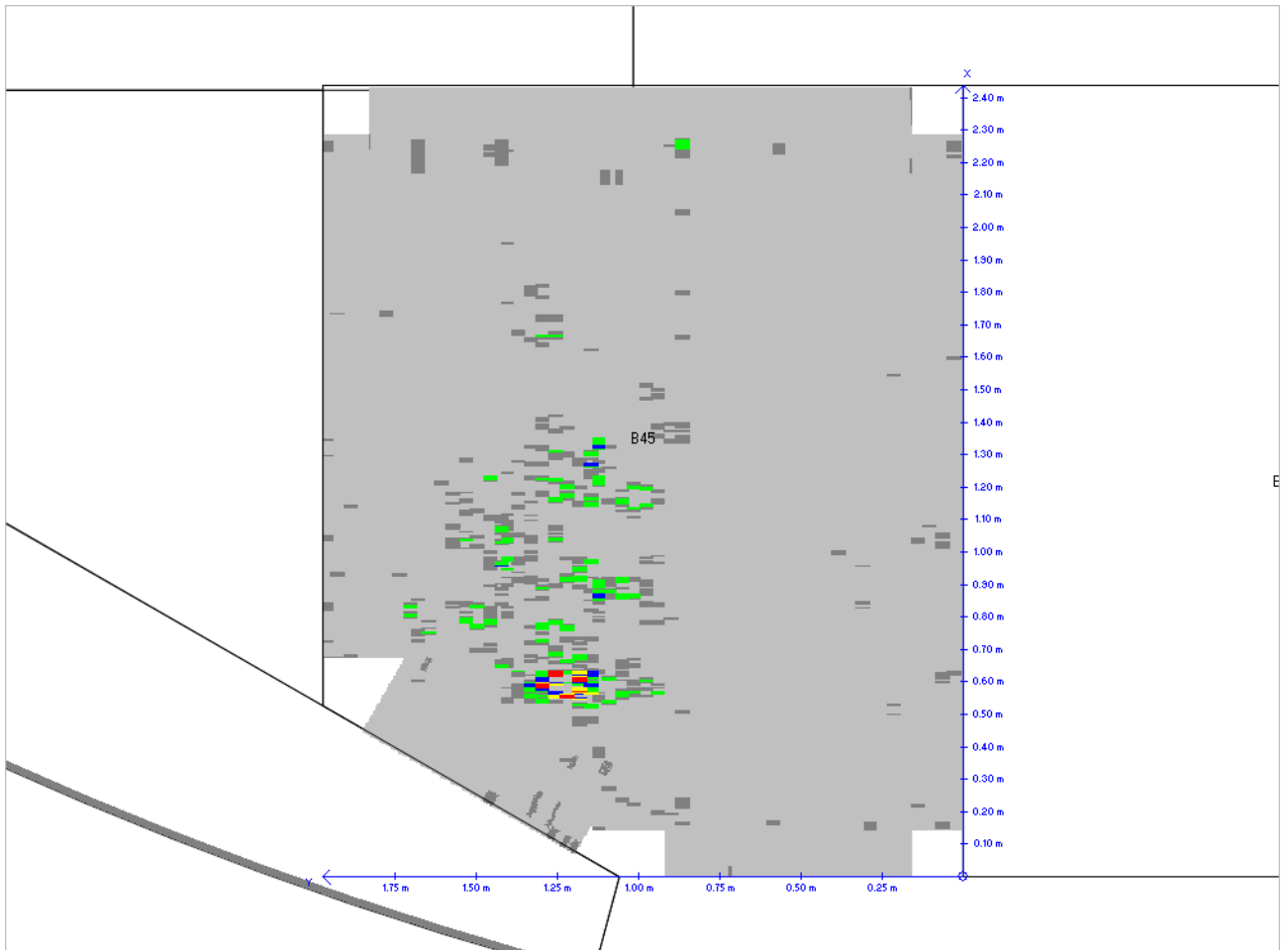

<ul style="list-style-type: none"> : Client a : Site b : 03/05/2016 : B 46 	<ul style="list-style-type: none"> : Tank 123 : K0xx-16 : Jxx86
--	--

Underside-Differential

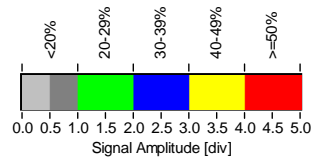
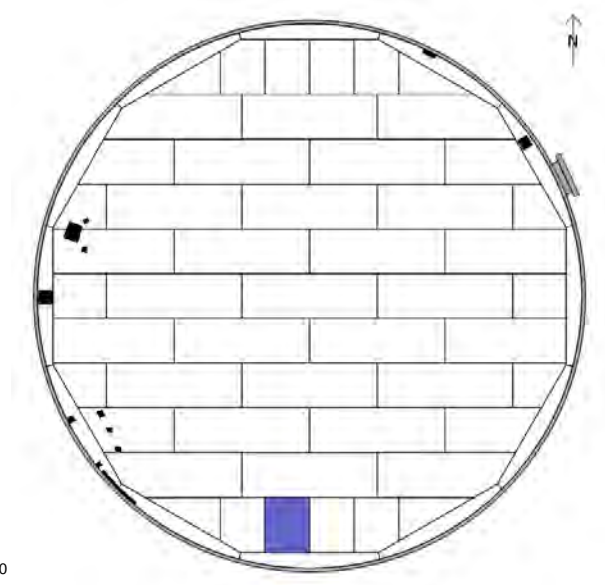
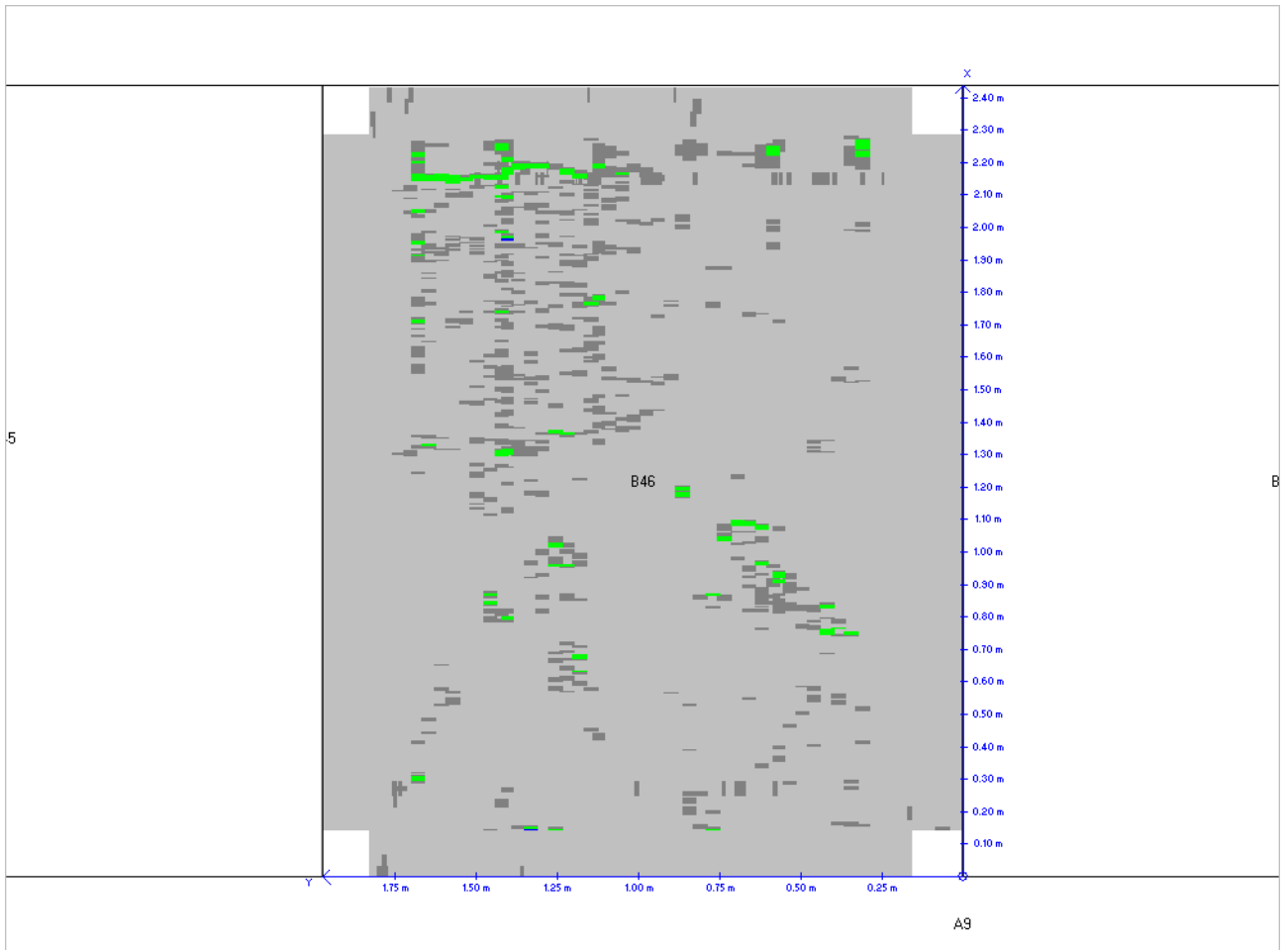

<ul style="list-style-type: none"> : Client a : Site b : 03/05/2016 : B 47 	<ul style="list-style-type: none"> : Tank 123 : K0xx-16 : Jxx86
--	--

Underside-Differential

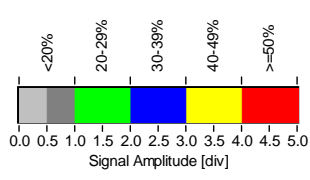
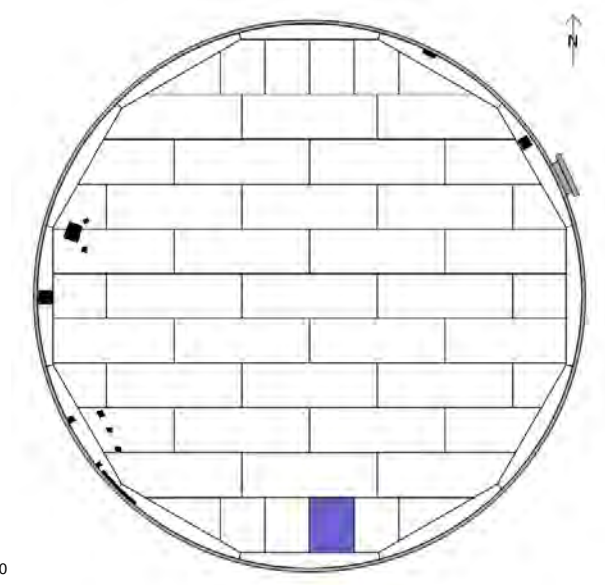
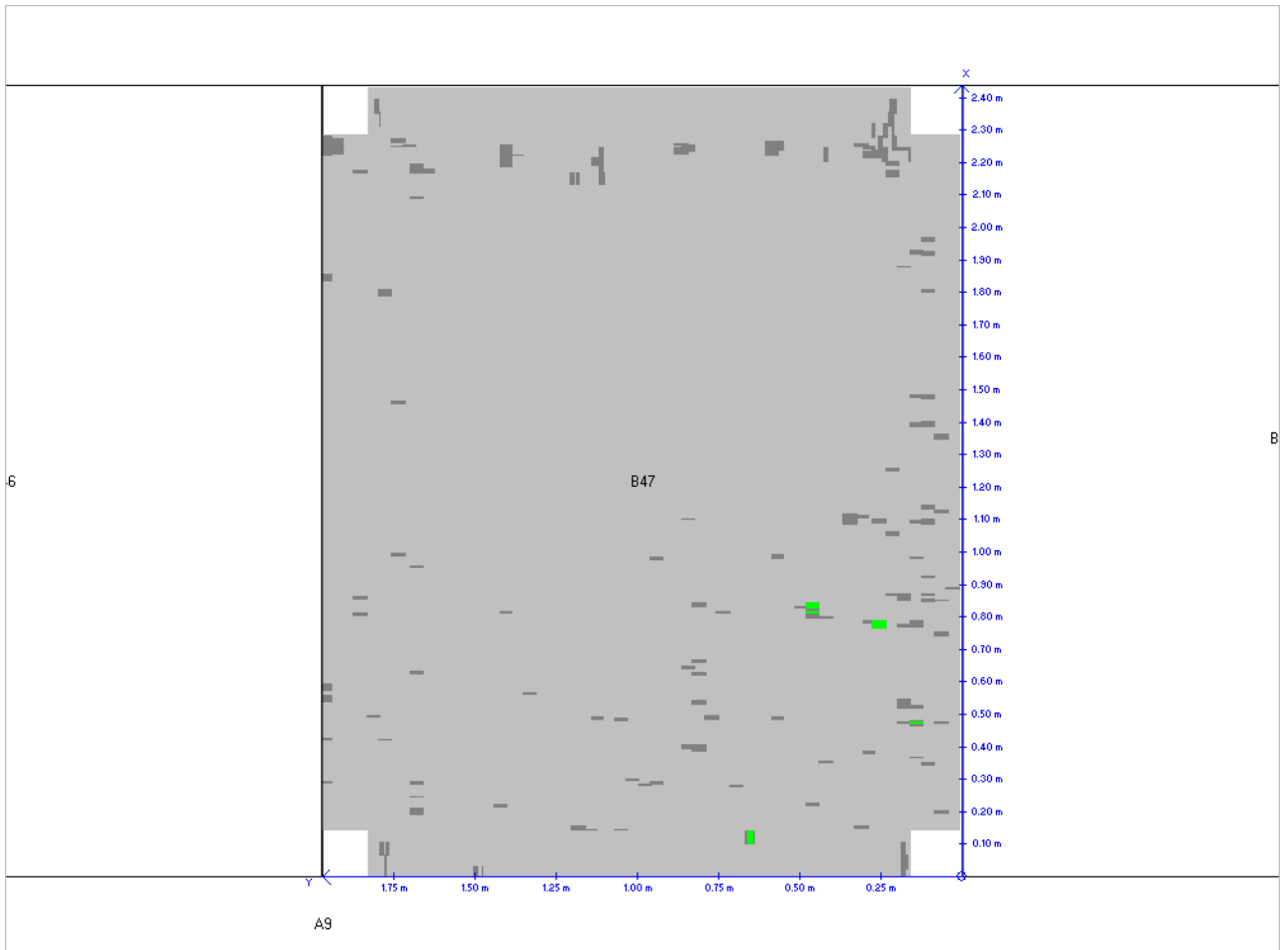

<ul style="list-style-type: none"> : Client a : Site b : 03/05/2016 : B 48 	<ul style="list-style-type: none"> : Tank b : K0xx-16 : Jxx86
--	--

Underside-Differential

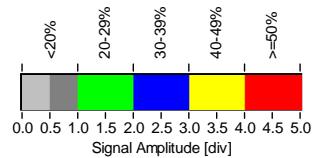
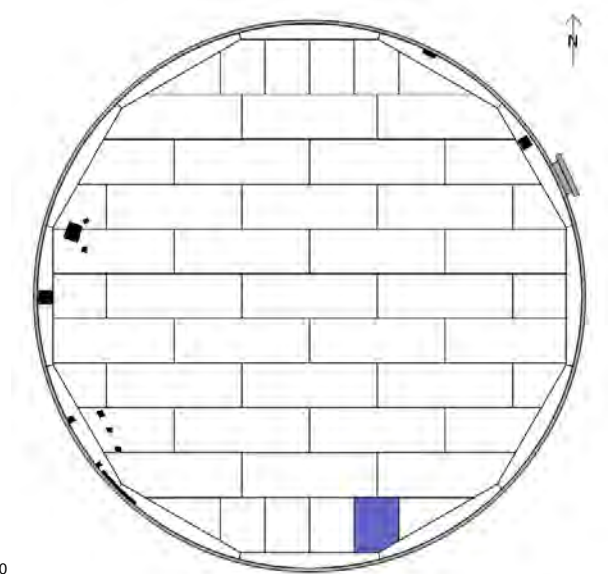
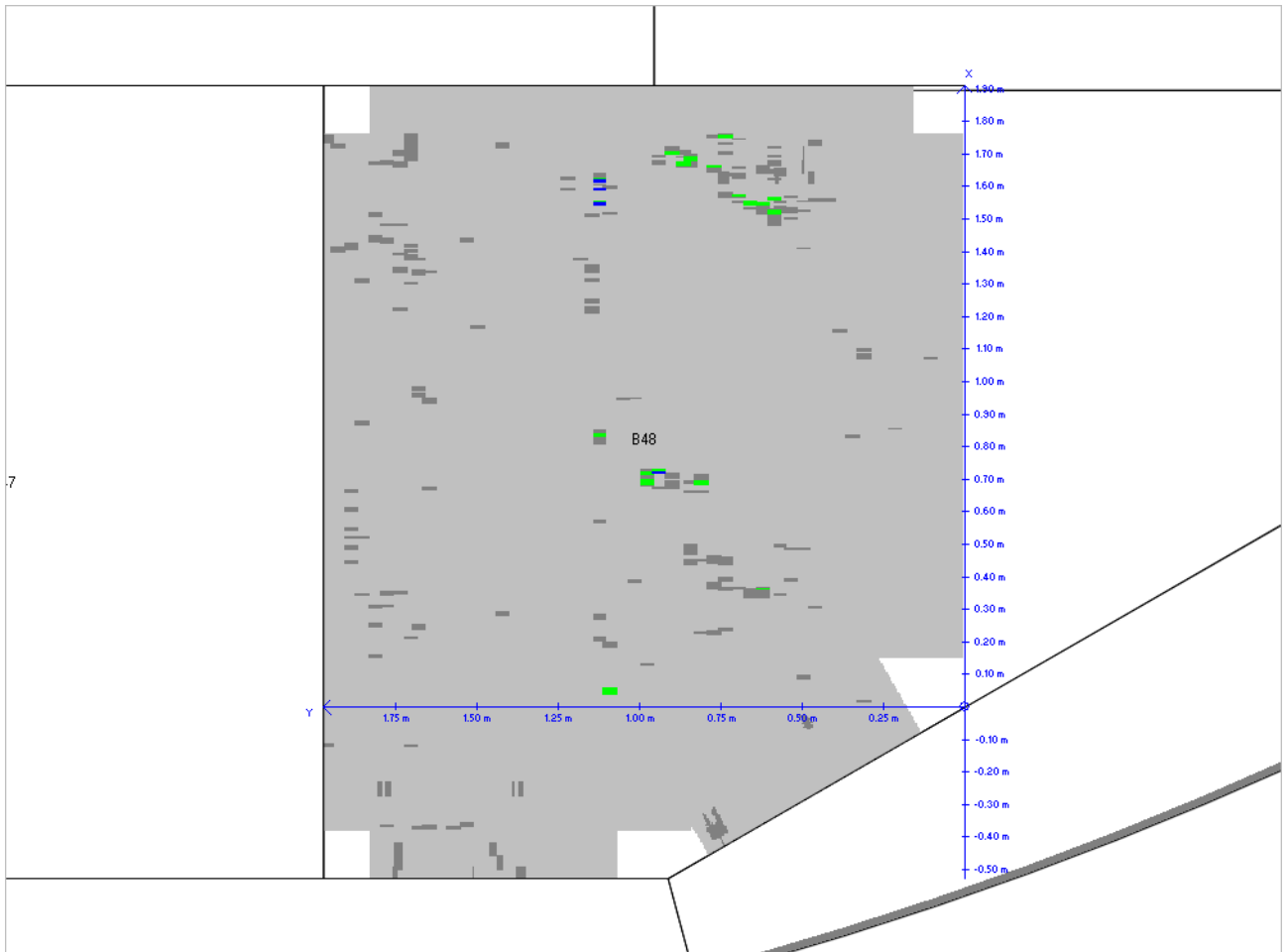

<ul style="list-style-type: none"> : Client a : Site b : 03/05/2016 : B 49 	<ul style="list-style-type: none"> : Tank 123 : K0xx-16 : Jxx86
--	--

Underside-Differential

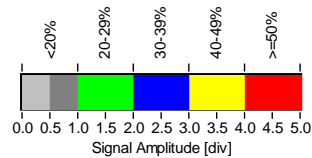
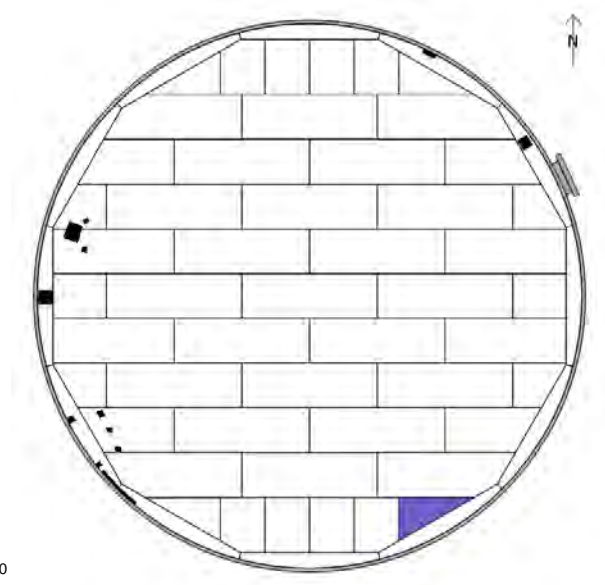
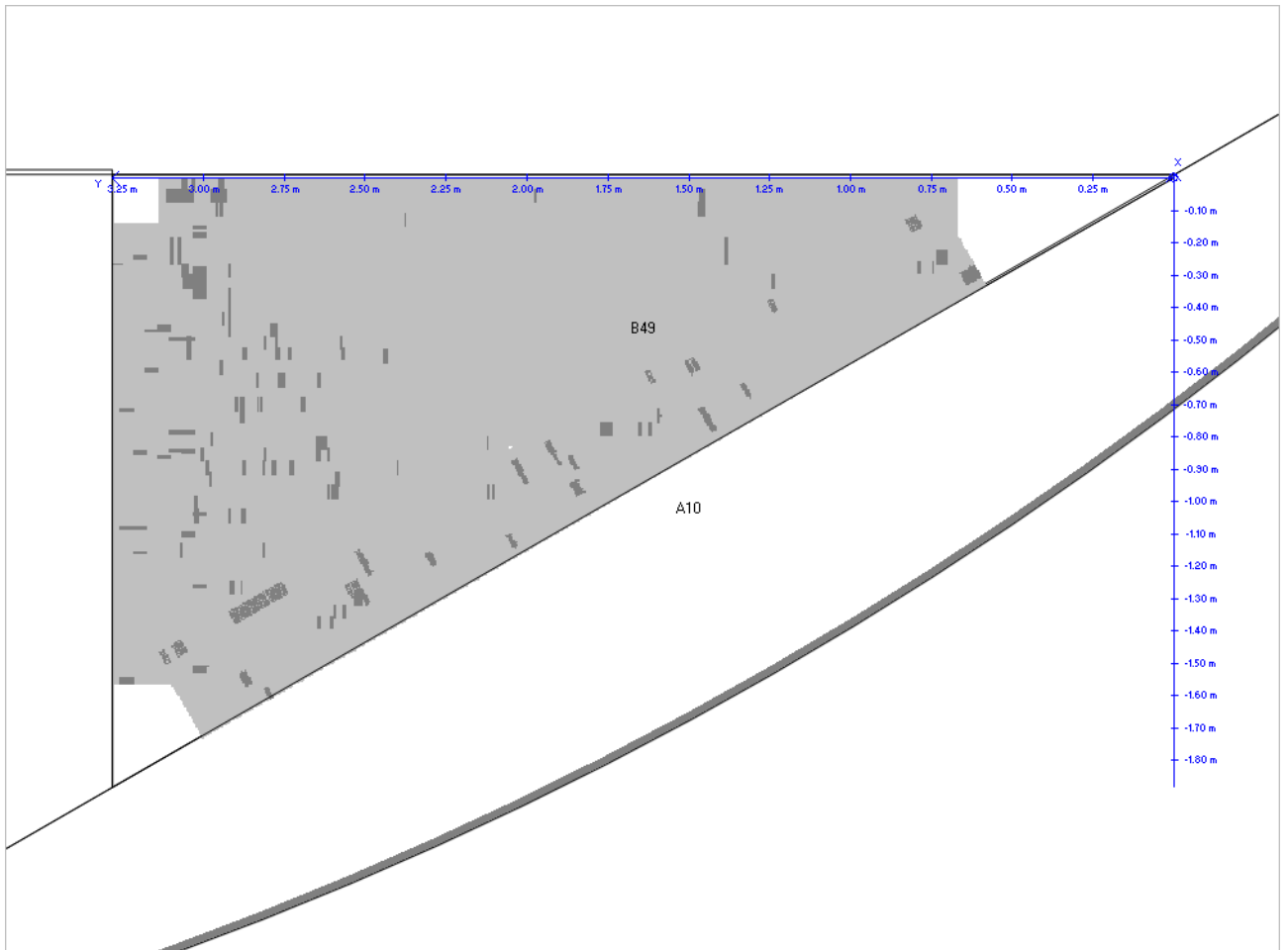



APPENDIX 02

Topside Condition Report

General Tank Floor Overview Individual Plate View

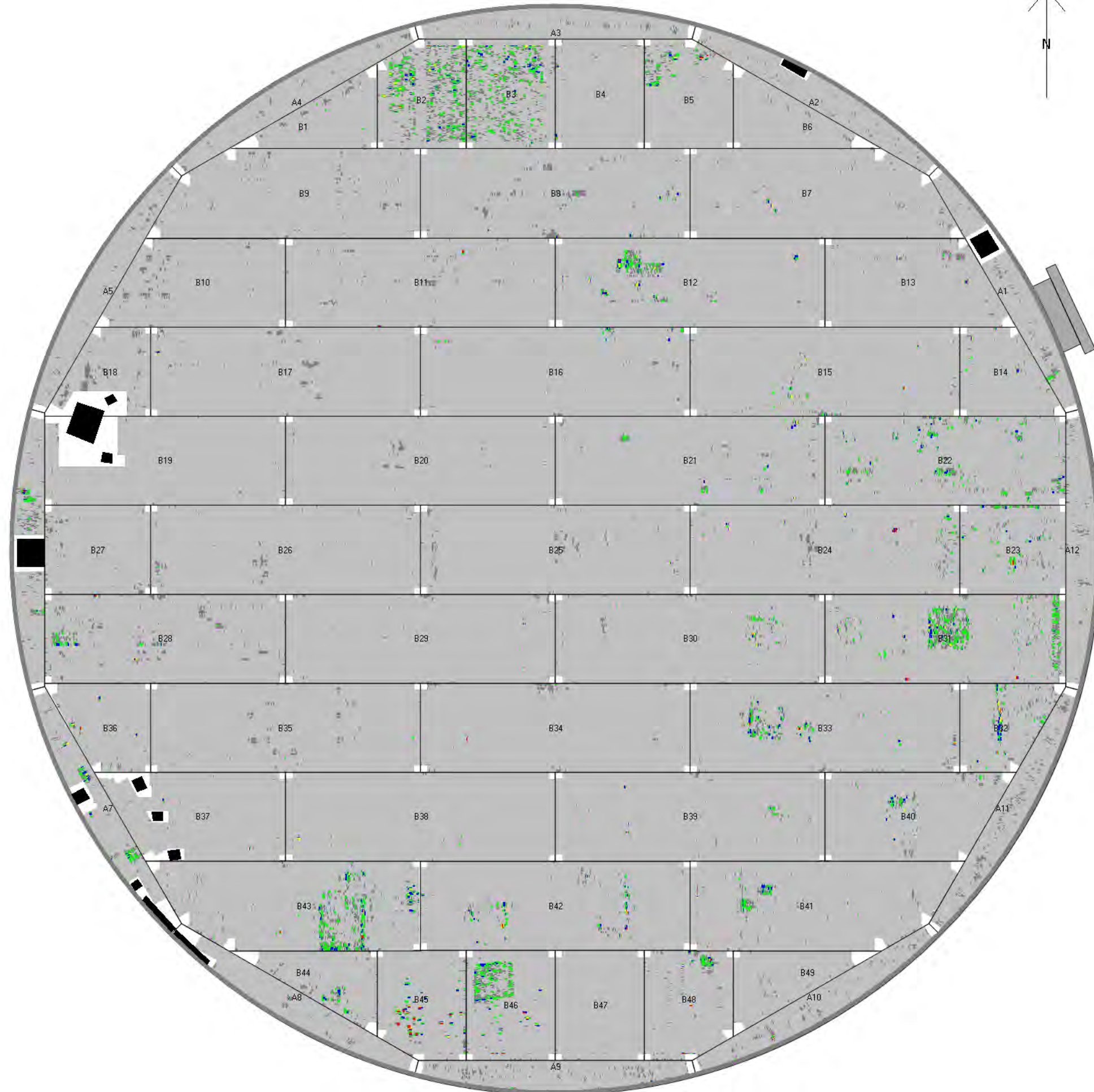

SLOFEC™

1 1

: Client a
 : Site b
 : Tank 123
 : 24.00 m
 : 452.39 qm
 : 8.00 mm
 : 9.60 mm
 : 0.00 mm
 : 0.00 mm
 : Jxx86
 : K0xx-16
 : 03/05/2016

Topside-Differential

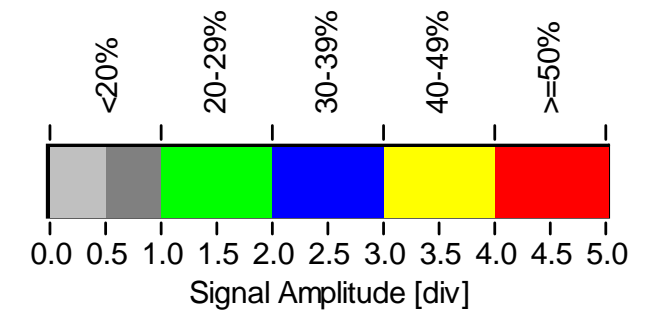

: Client a : Site b : 03/05/2016 : A 1	: Tank 123 : K0xx-16 : Jxx86
---	------------------------------------

Topside-Differential

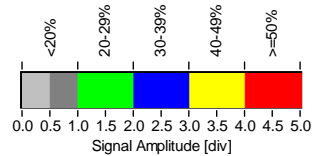
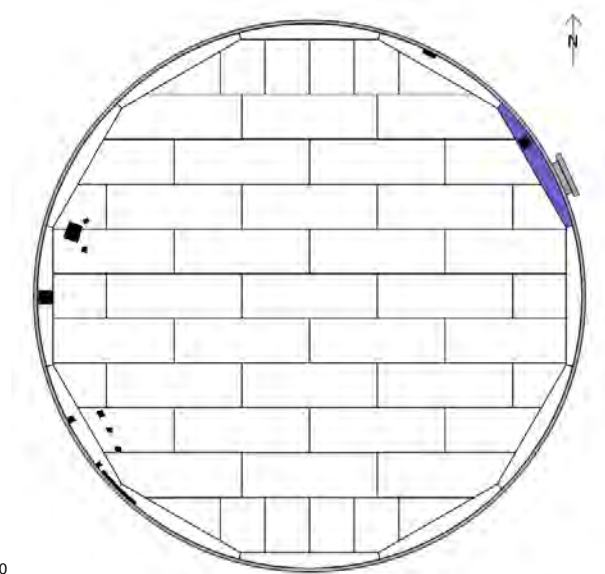
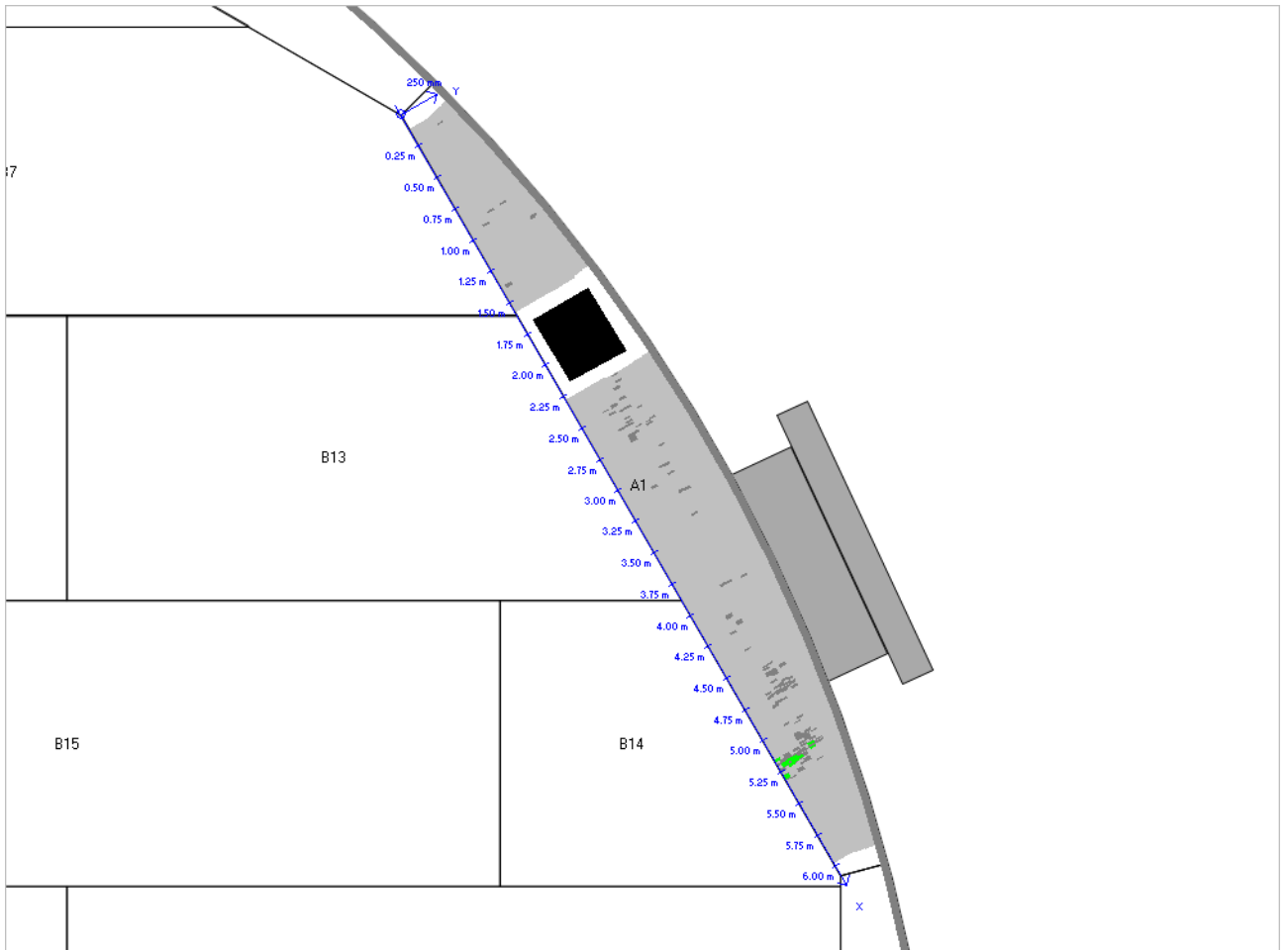

<ul style="list-style-type: none"> : Client a : Site b : 03/05/2016 : A 2 	<ul style="list-style-type: none"> : Tank 123 : K0xx-16 : Jxx86
---	--

Topside-Differential

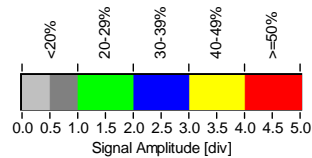
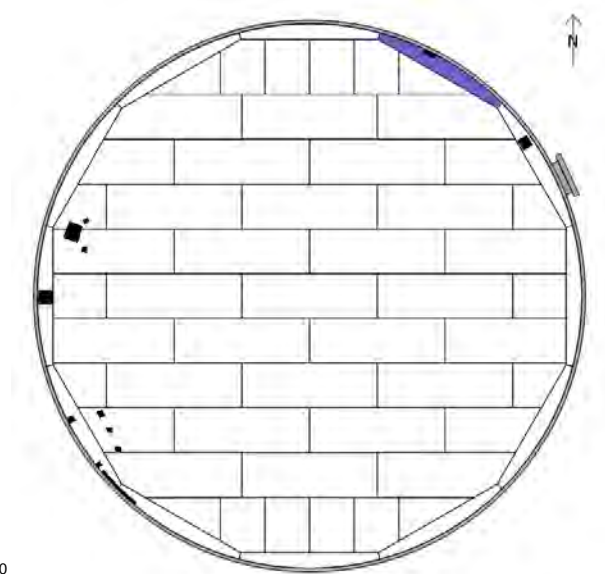
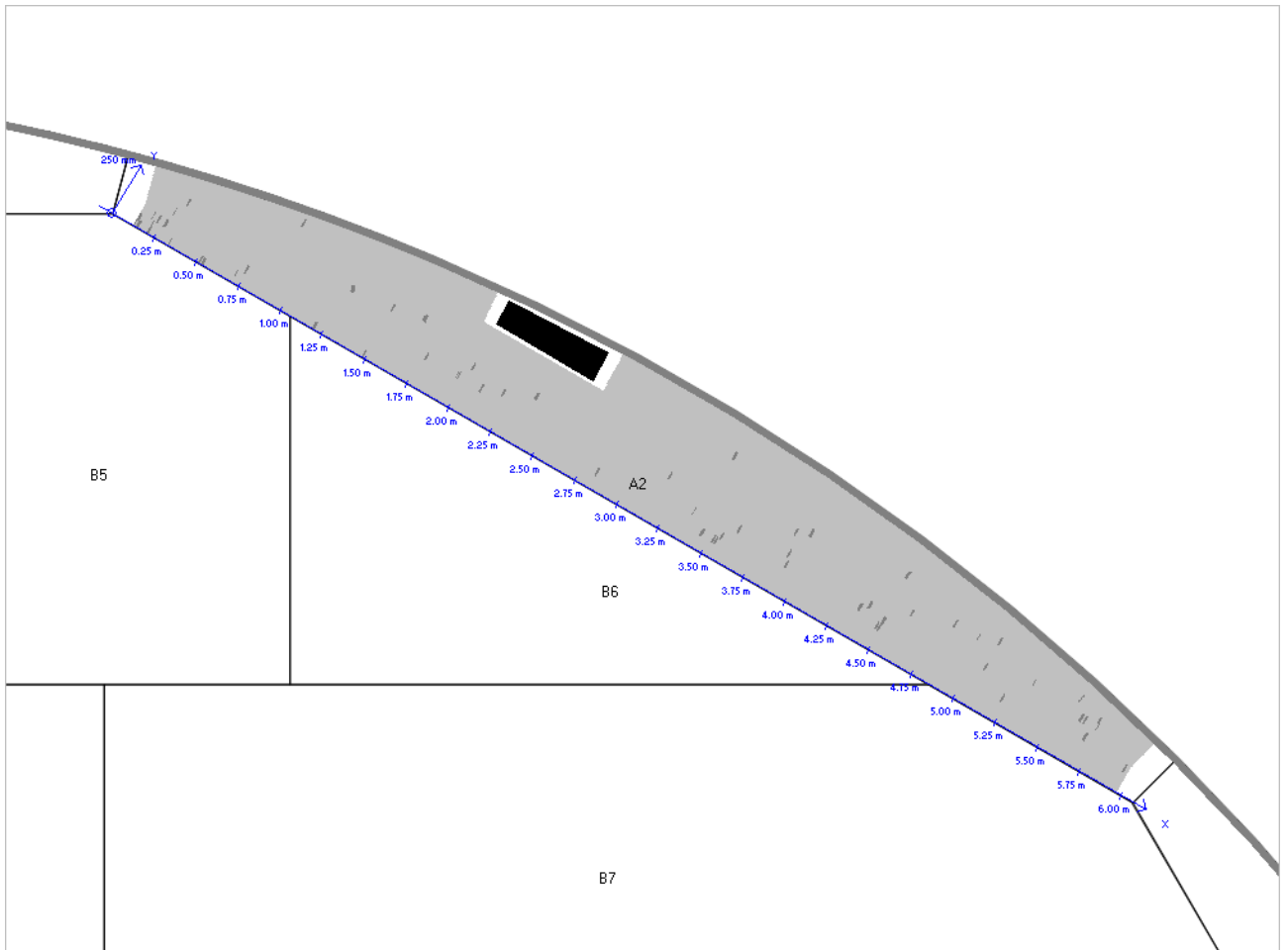

<ul style="list-style-type: none"> : Client a : Site b : 03/05/2016 : A 3 	<ul style="list-style-type: none"> : Tank 123 : K0xx-16 : Jxx86
---	--

Topside-Differential

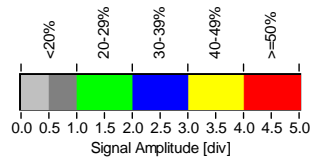
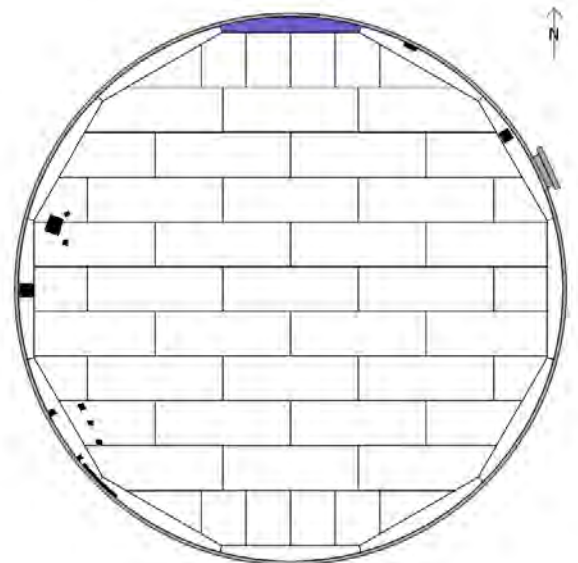
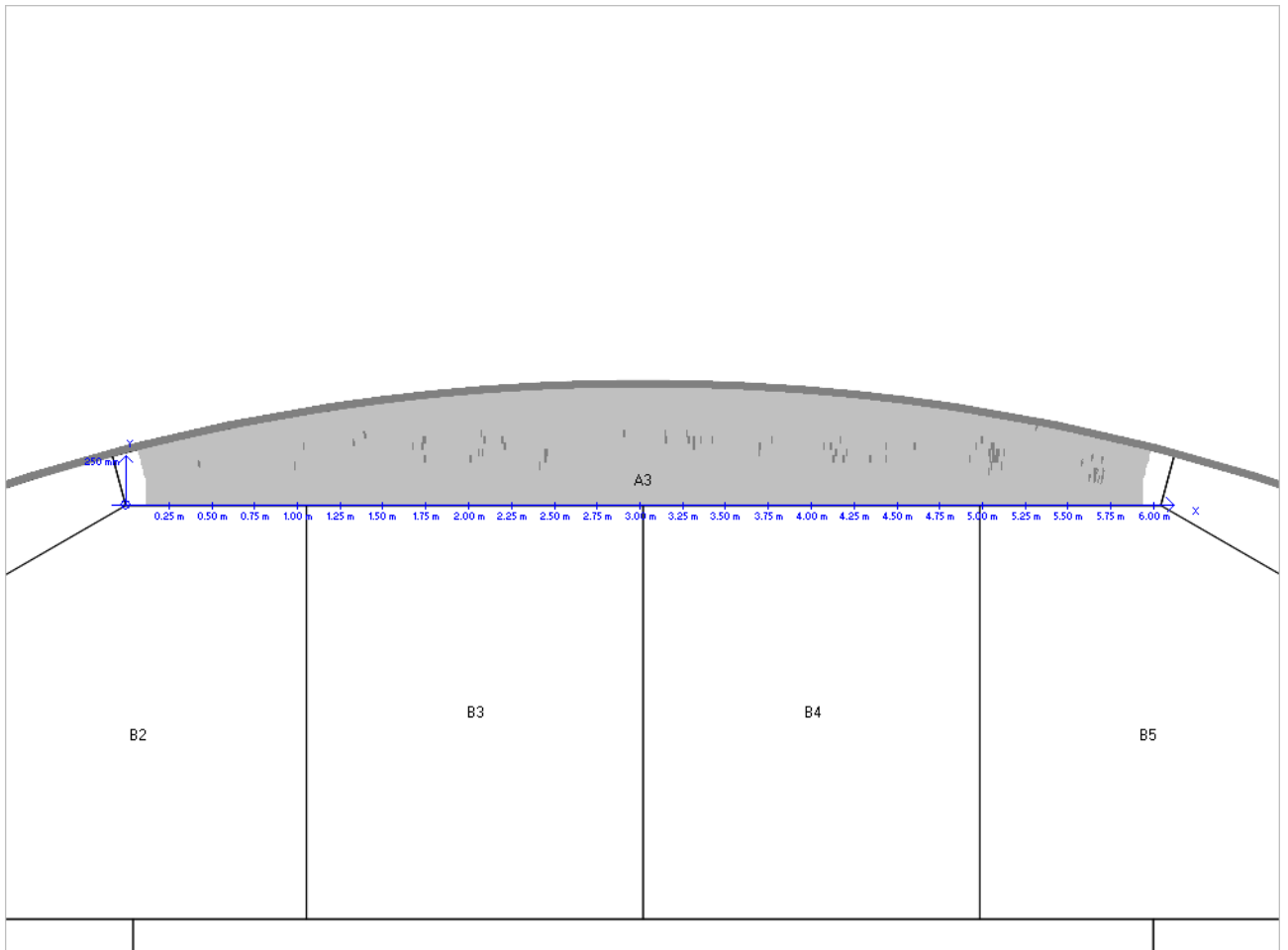

<ul style="list-style-type: none"> : Client a : Site b : 03/05/2016 : A 4 	<ul style="list-style-type: none"> : Tank 123 : K0xx-16 : Jxx86
---	--

Topside-Differential

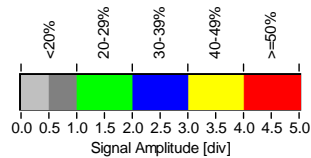
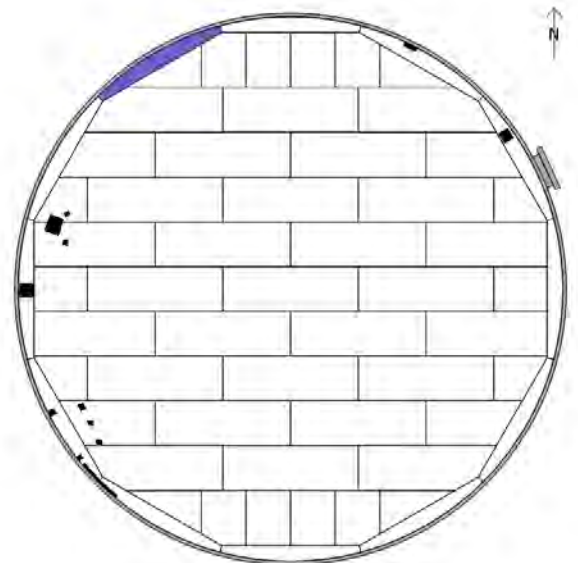
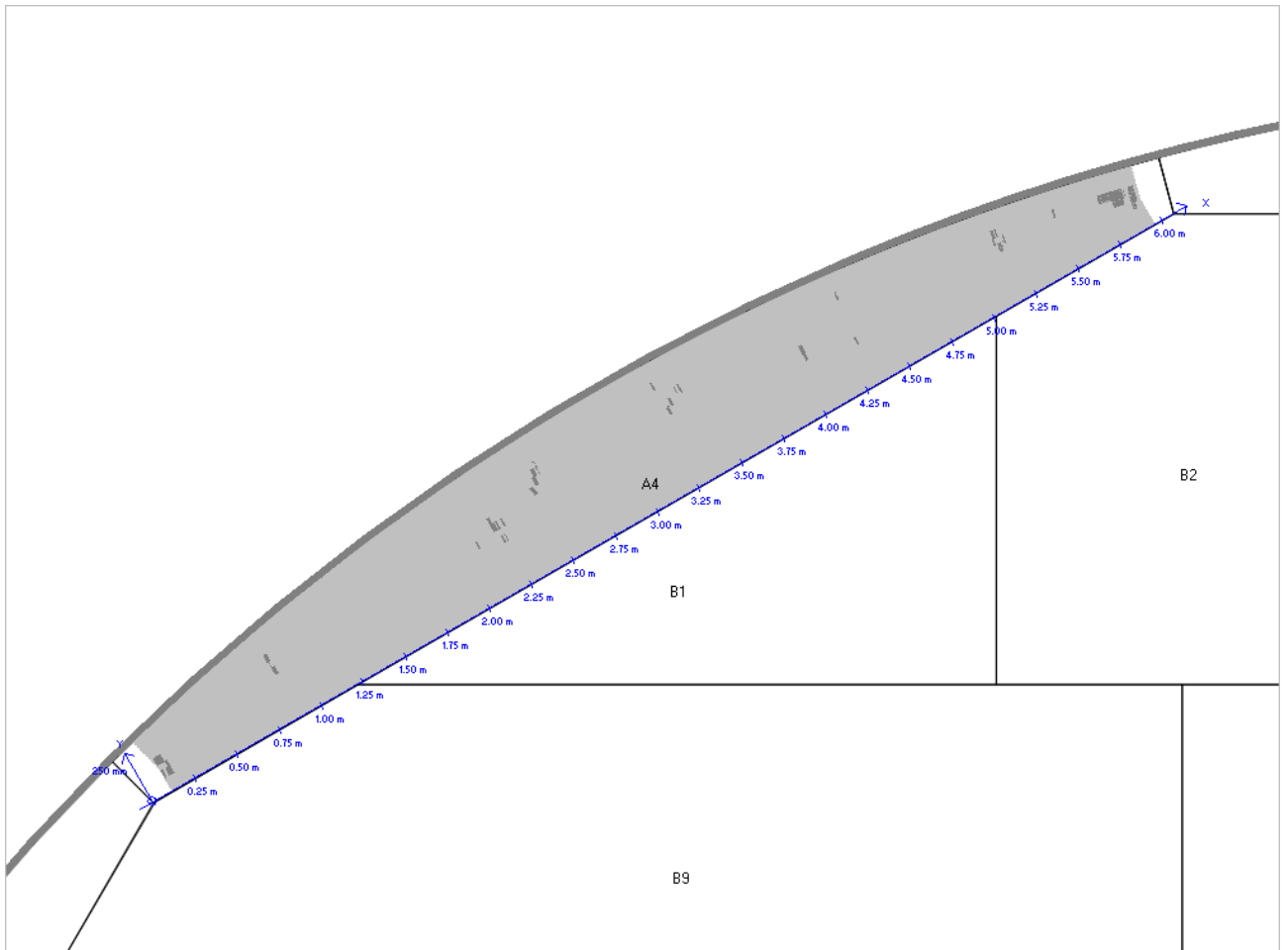

<ul style="list-style-type: none"> : Client a : Site b : 03/05/2016 : A 5 	<ul style="list-style-type: none"> : Tank 123 : K0xx-16 : Jxx86
---	--

Topside-Differential

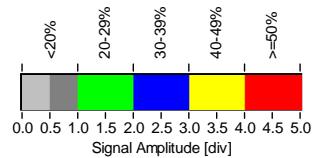
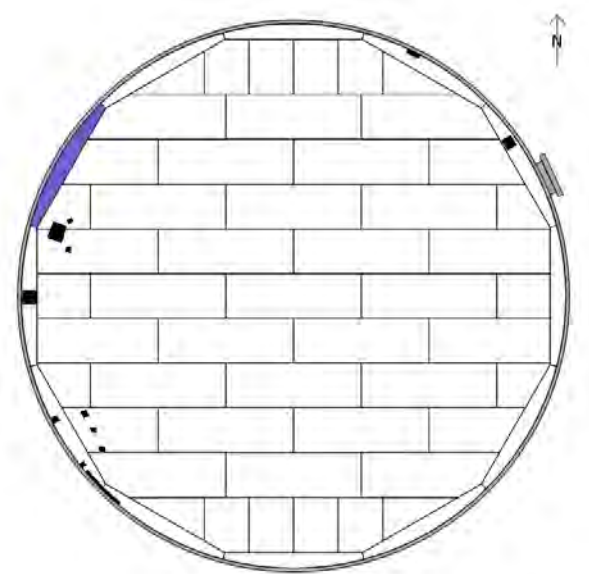
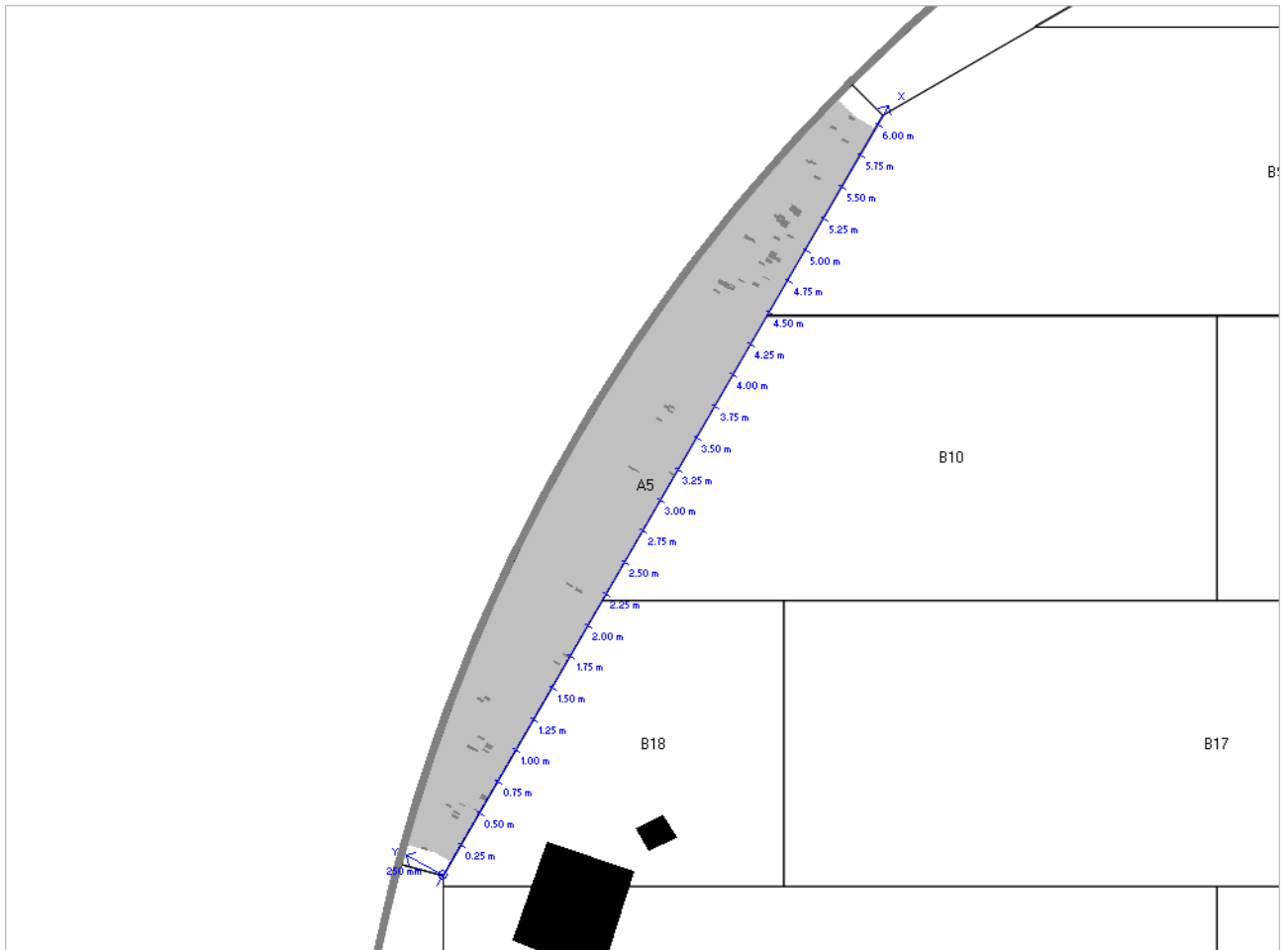

<ul style="list-style-type: none"> : Client a : Site b : 03/05/2016 : A 6 	<ul style="list-style-type: none"> : Tank 123 : K0xx-16 : Jxx86
---	--

Topside-Differential

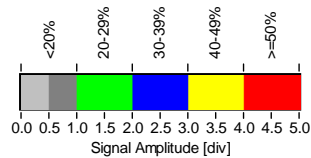
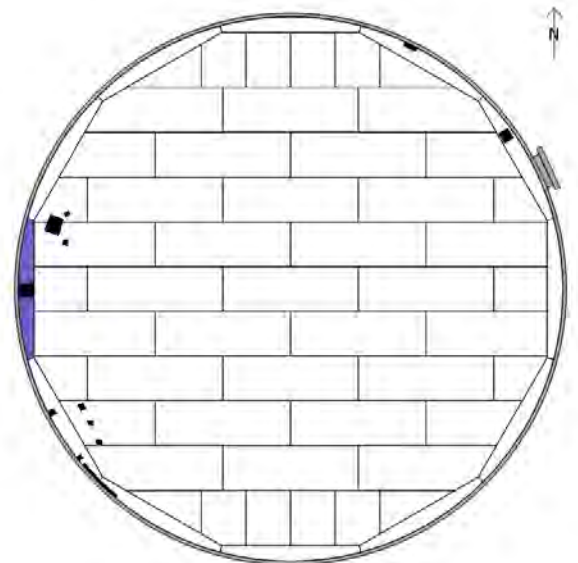
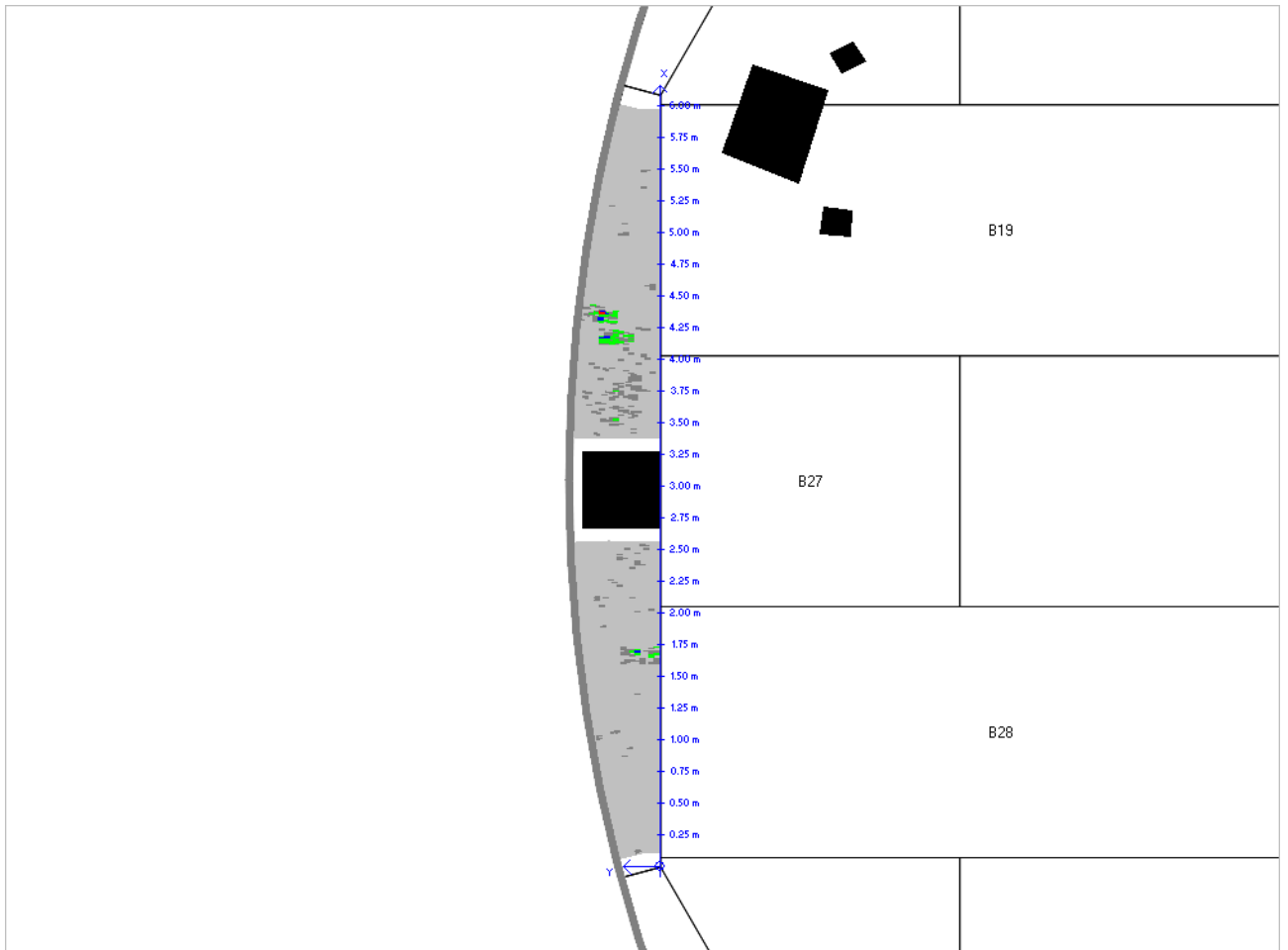

: Client a : Site b : 03/05/2016 : A 7	: Tank 123 : K0xx-16 : Jxx86
---	------------------------------------

Topside-Differential

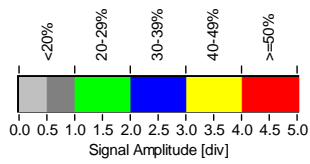
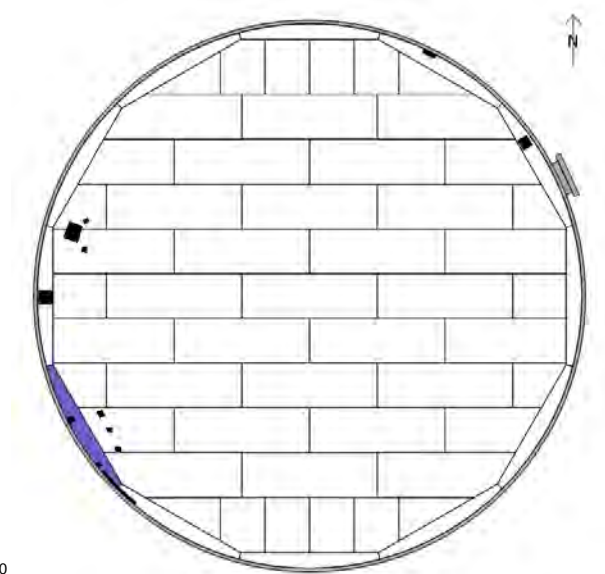
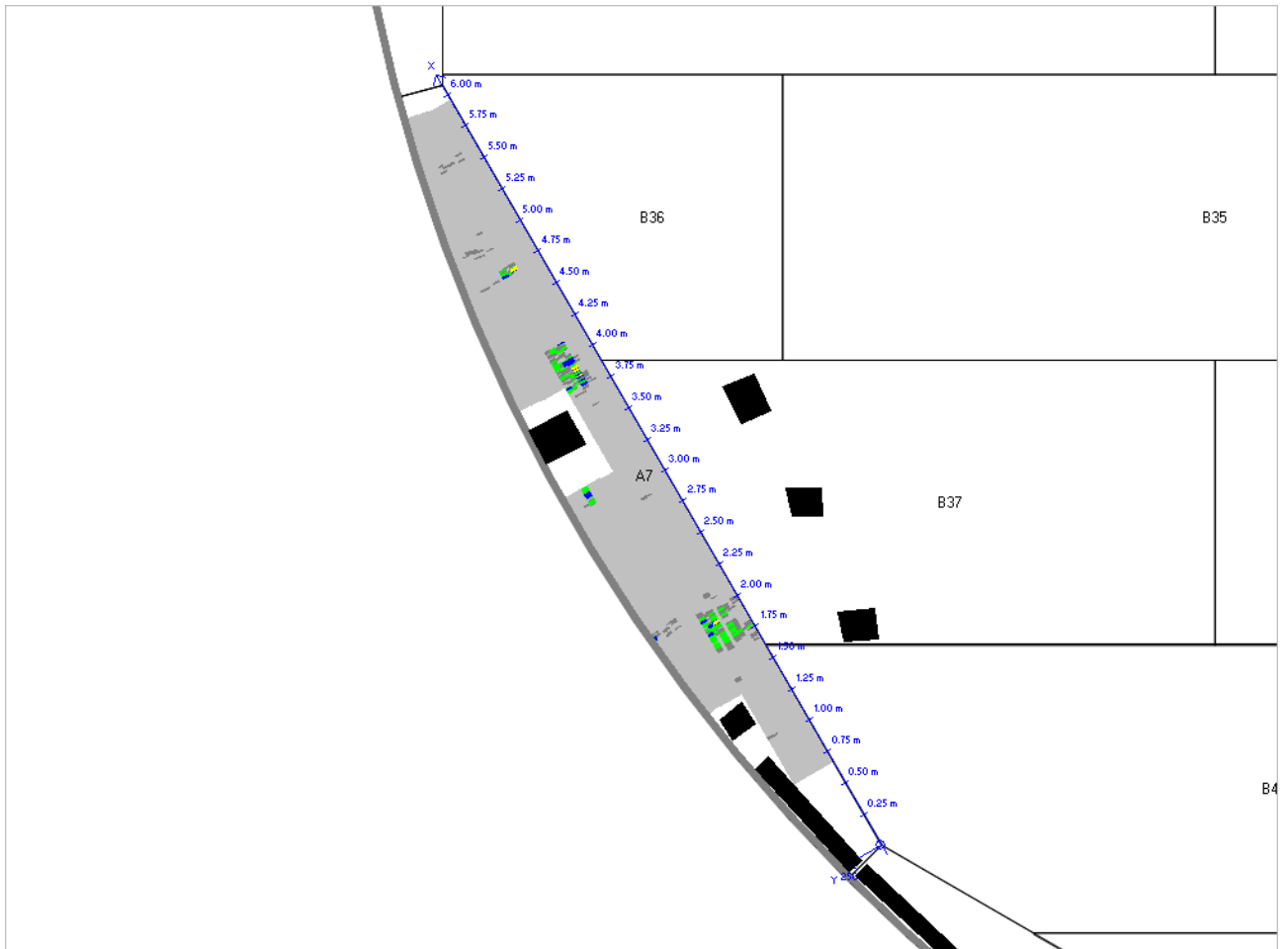

<ul style="list-style-type: none"> : Client a : Site b : 03/05/2016 : A 8 	<ul style="list-style-type: none"> : Tank 123 : K0xx-16 : Jxx86
---	--

Topside-Differential

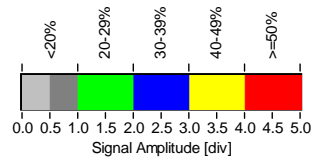
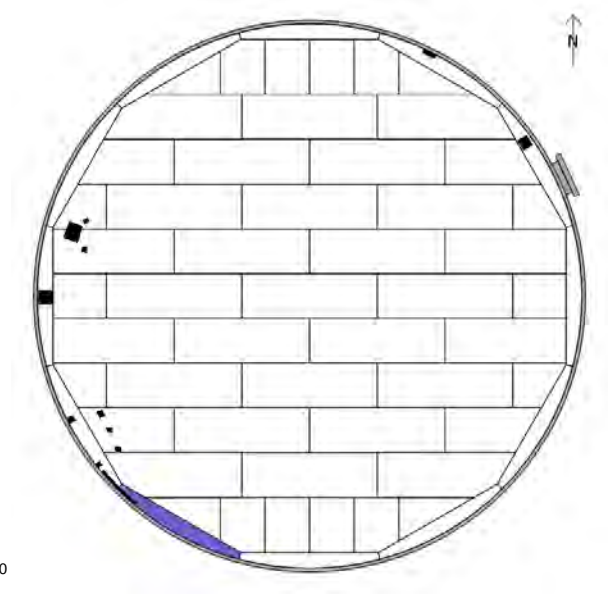
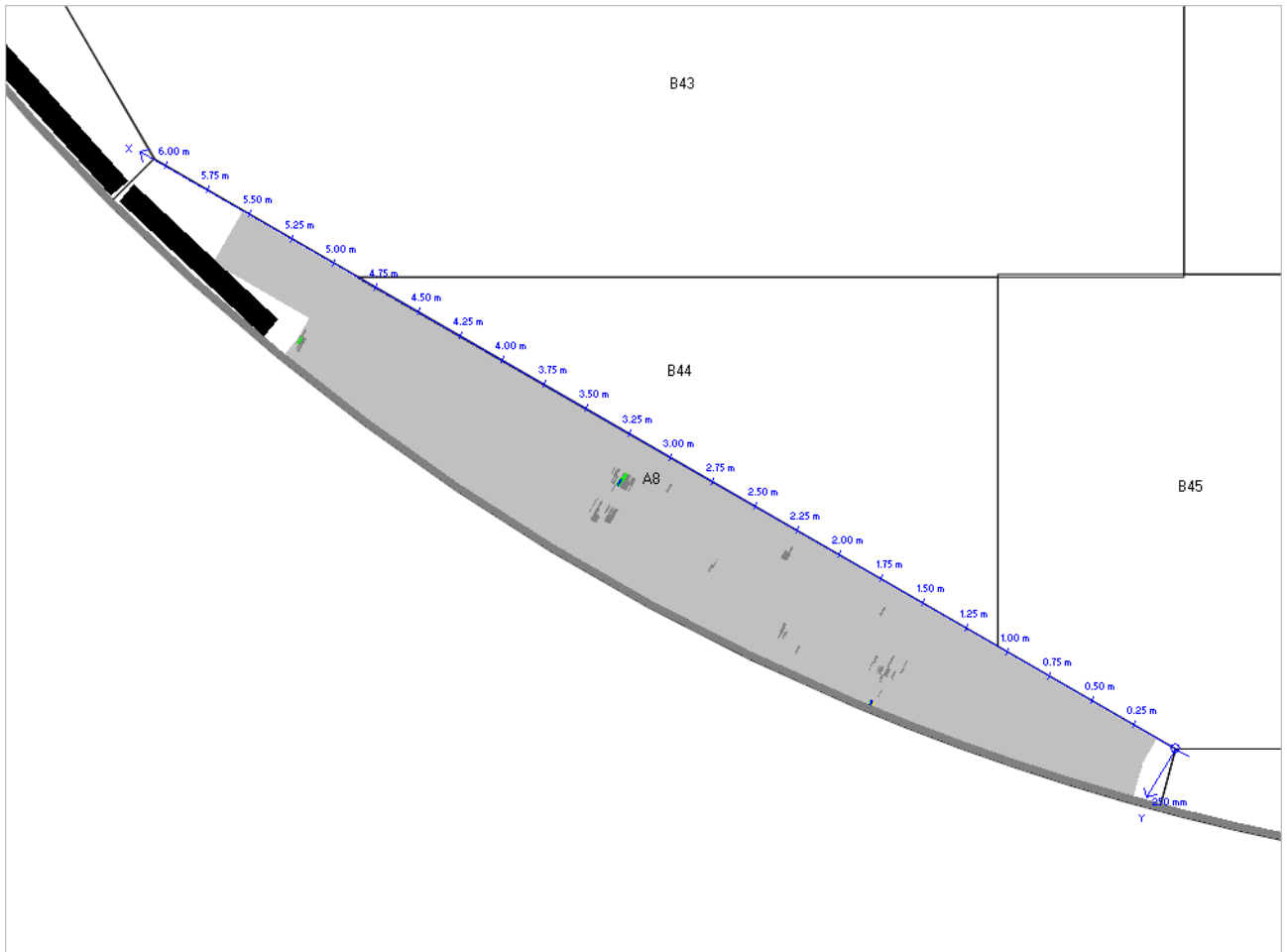

<ul style="list-style-type: none"> : Client a : Site b : 03/05/2016 : A 9 	<ul style="list-style-type: none"> : Tank 123 : K0xx-16 : Jxx86
---	--

Topside-Differential

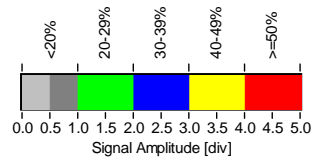
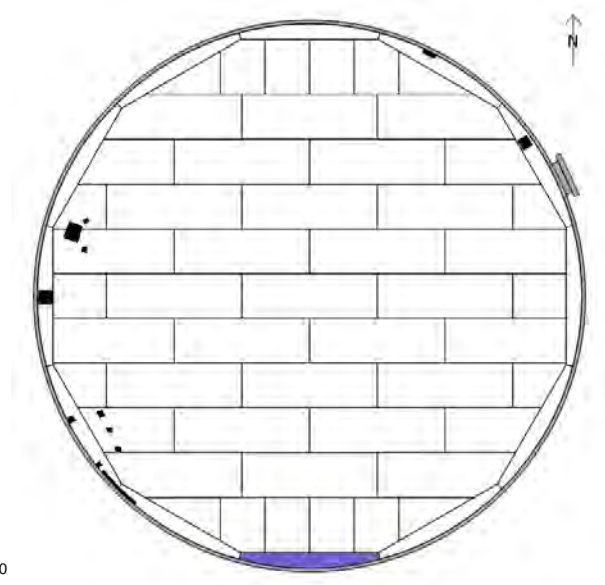
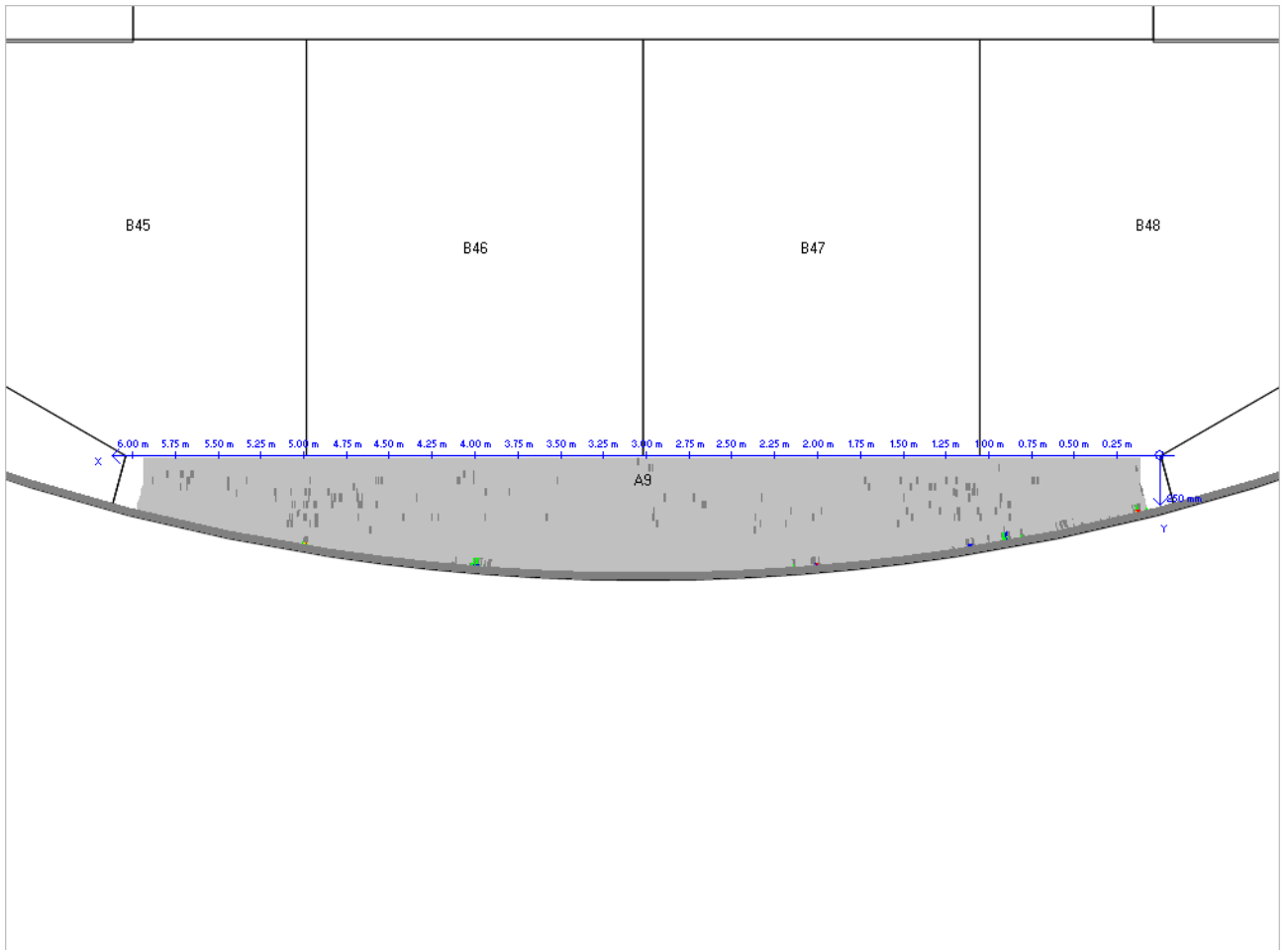

: Client a	: Tank 123
: Site b	: K0xx-16
: 03/05/2016	: Jxx86
: A 10	

Topside-Differential

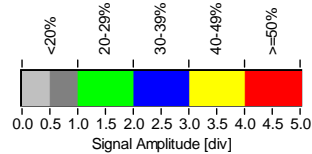
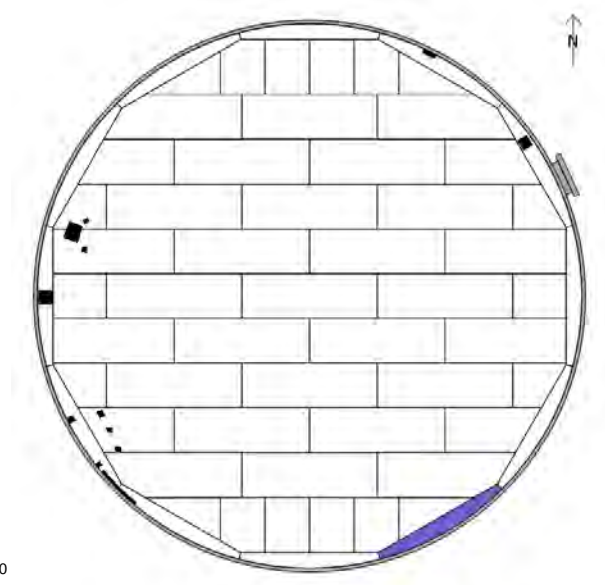
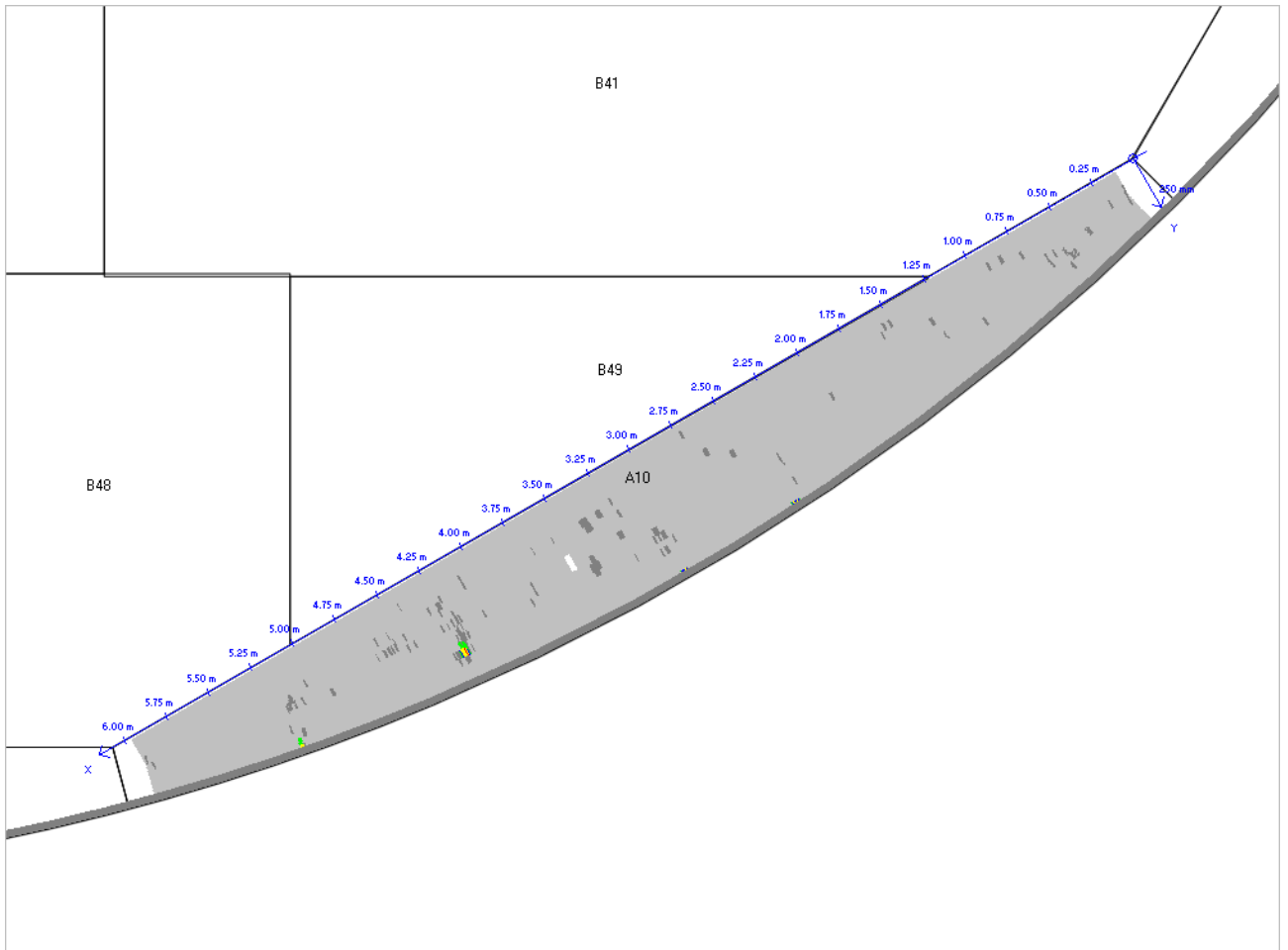

<ul style="list-style-type: none"> : Client a : Site b : 03/05/2016 : A 11 	<ul style="list-style-type: none"> : Tank 123 : K0xx-16 : Jxx86
--	--

Topside-Differential

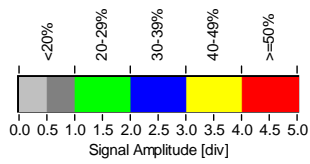
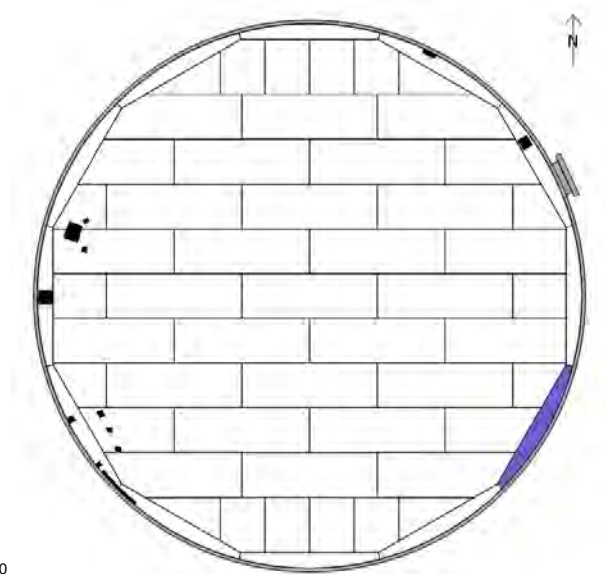
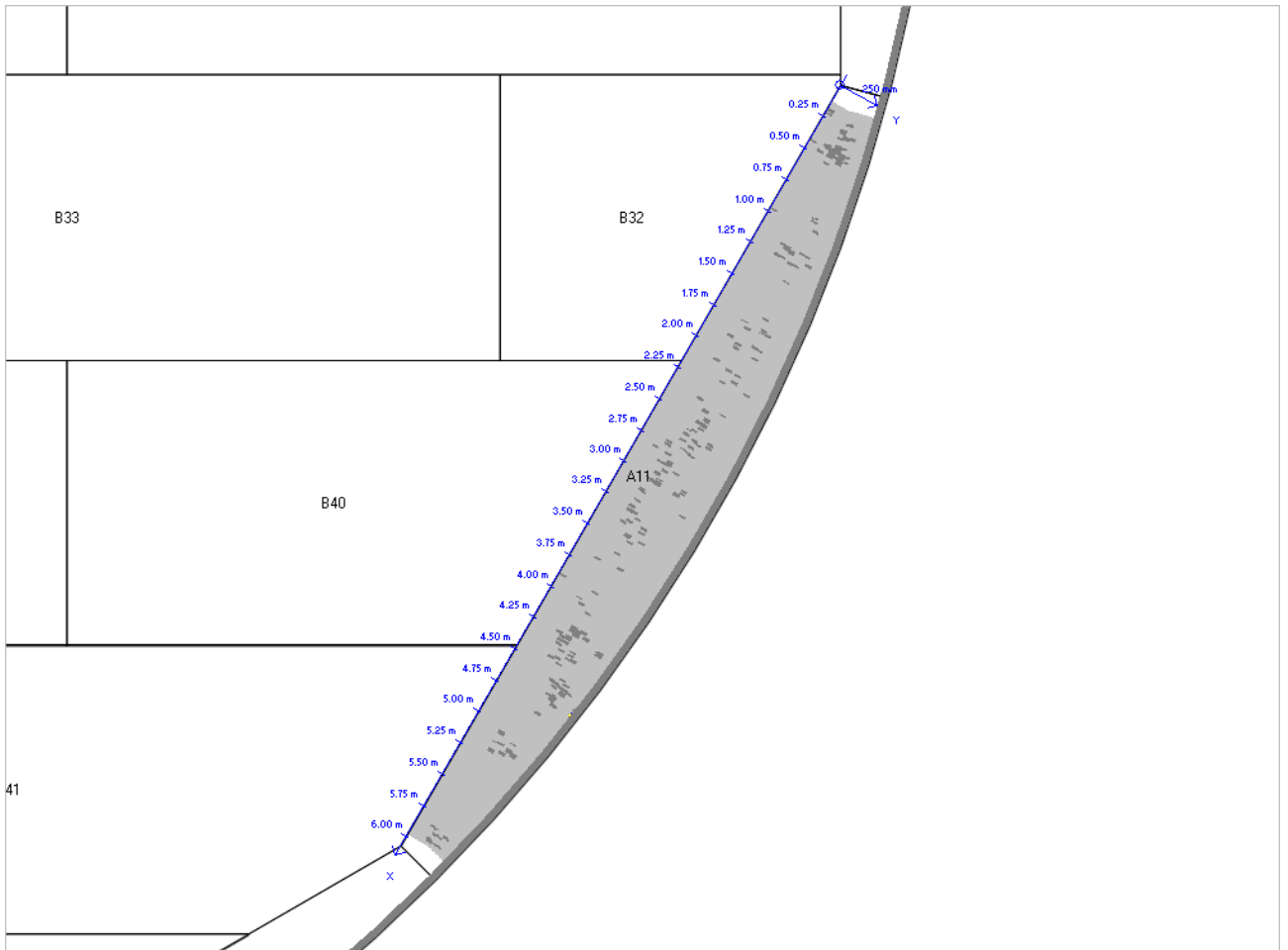

: Client a : Site b : 03/05/2016 : A 12	: Tank 123 : K0xx-16 : Jxx86
--	------------------------------------

Topside-Differential

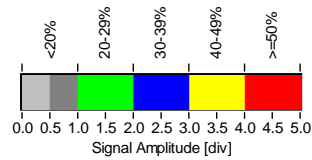
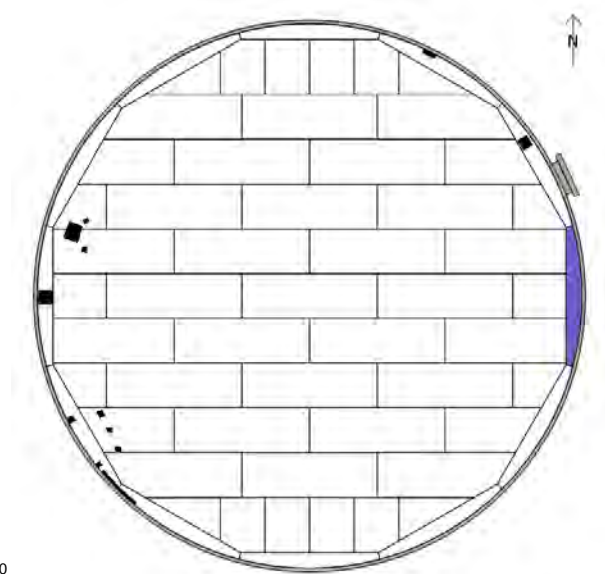
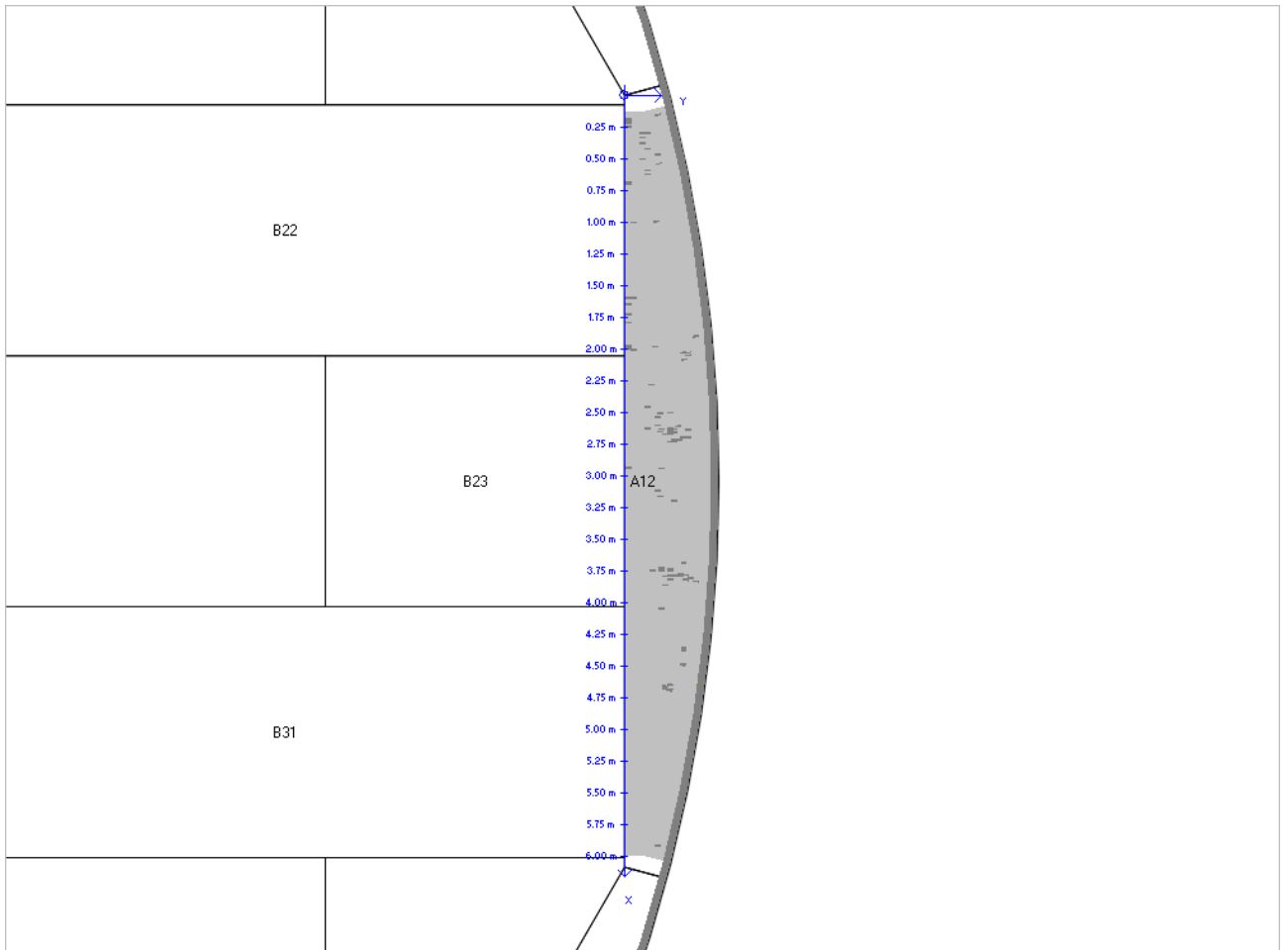

<ul style="list-style-type: none"> : Client a : Site b : 03/05/2016 : B 1 	<ul style="list-style-type: none"> : Tank 123 : K0xx-16 : Jxx86
---	--

Topside-Differential

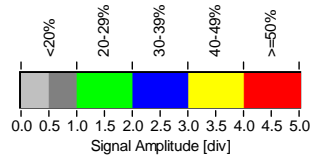
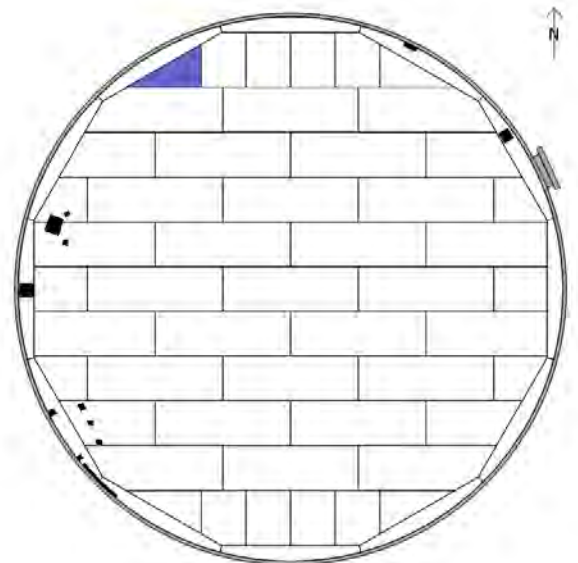
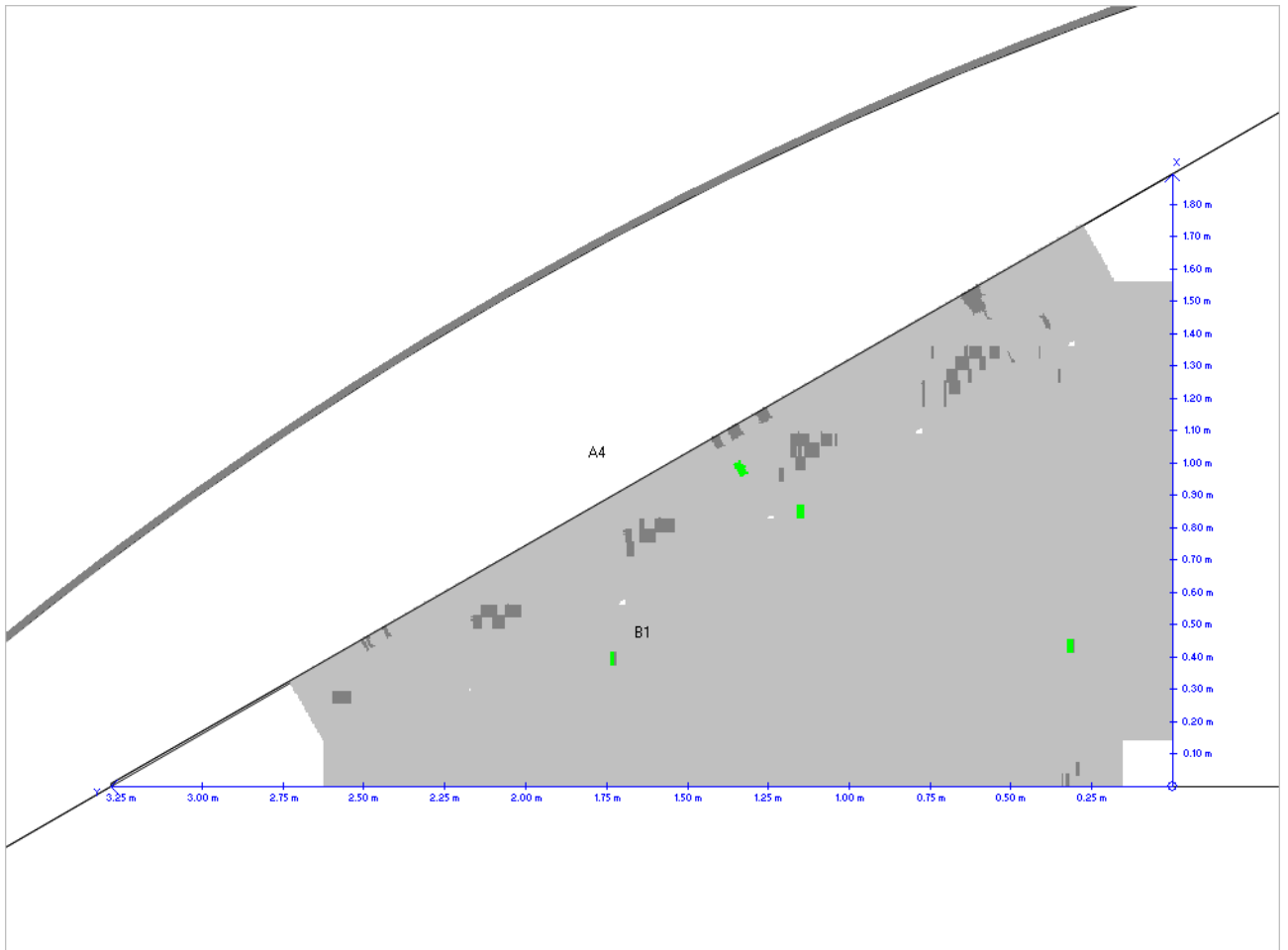

<ul style="list-style-type: none"> : Client a : Site b : 03/05/2016 : B 2 	<ul style="list-style-type: none"> : Tank 123 : K0xx-16 : Jxx86
---	--

Topside-Differential

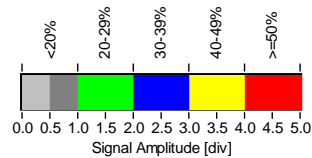
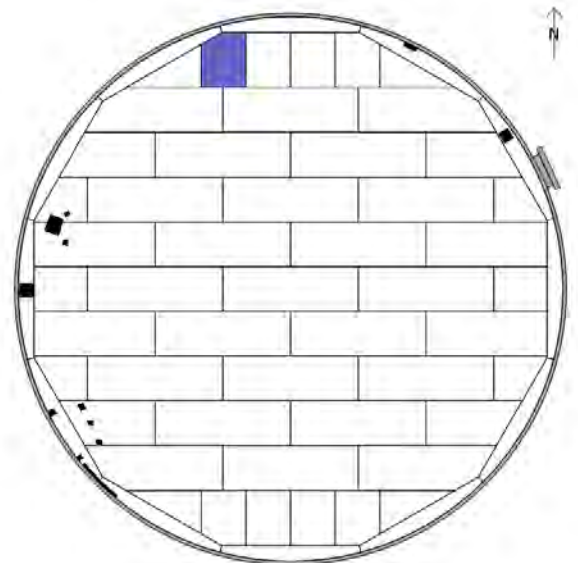
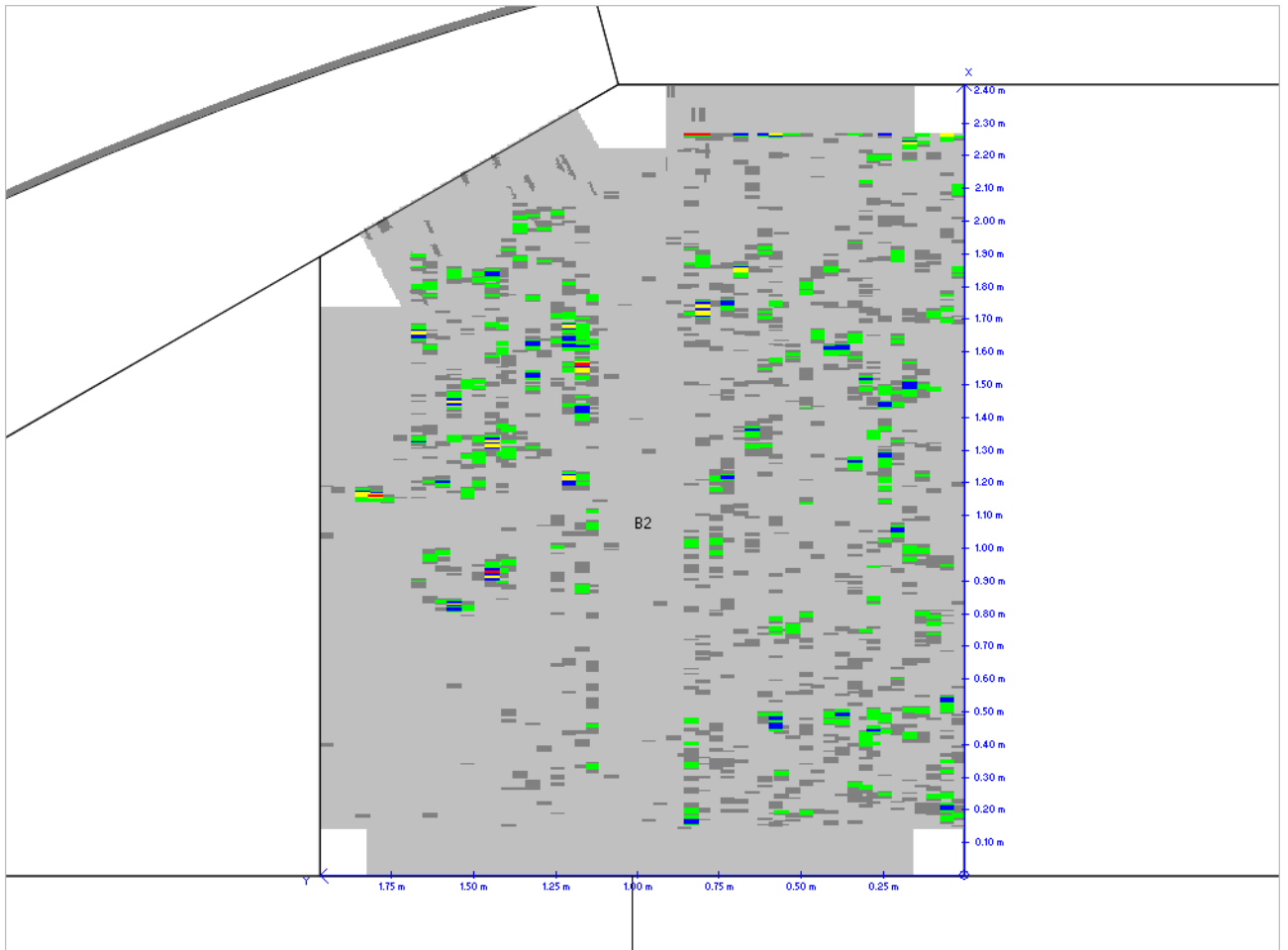

<ul style="list-style-type: none"> : Client a : Site b : 03/05/2016 : B 3 	<ul style="list-style-type: none"> : Tank 123 : K0xx-16 : Jxx86
---	--

Topside-Differential

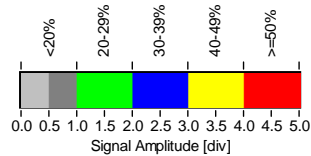
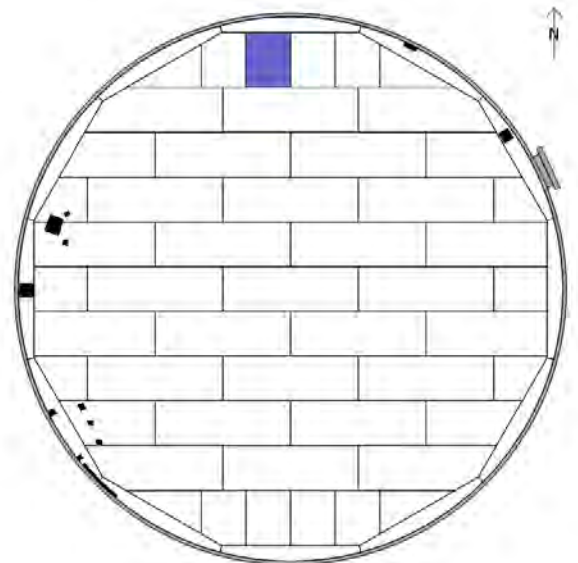
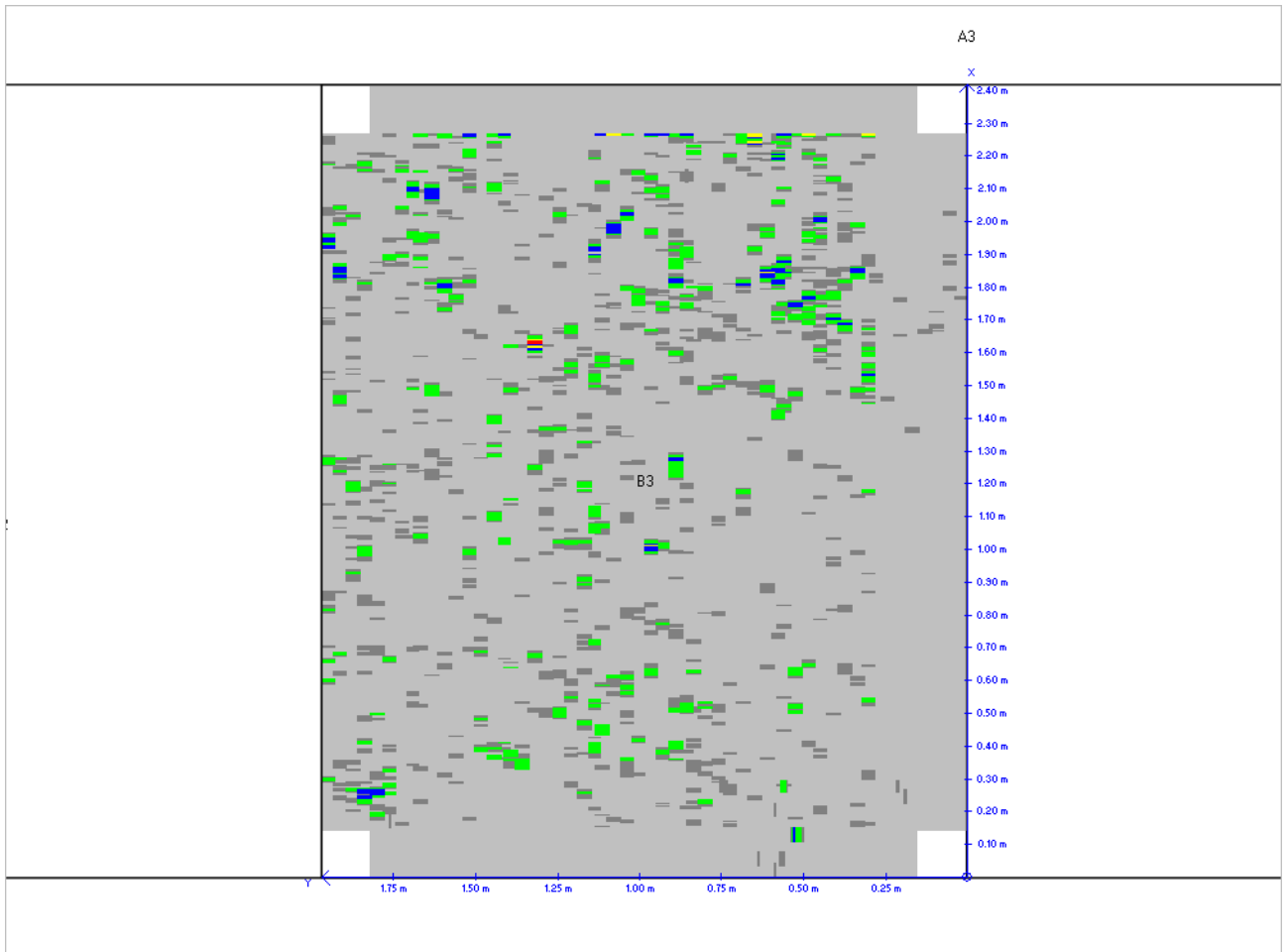

: Client a : Site b : 03/05/2016 : B 4	: Tank 123 : K0xx-16 : Jxx86
---	------------------------------------

Topside-Differential

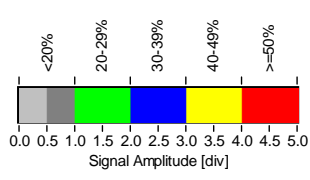
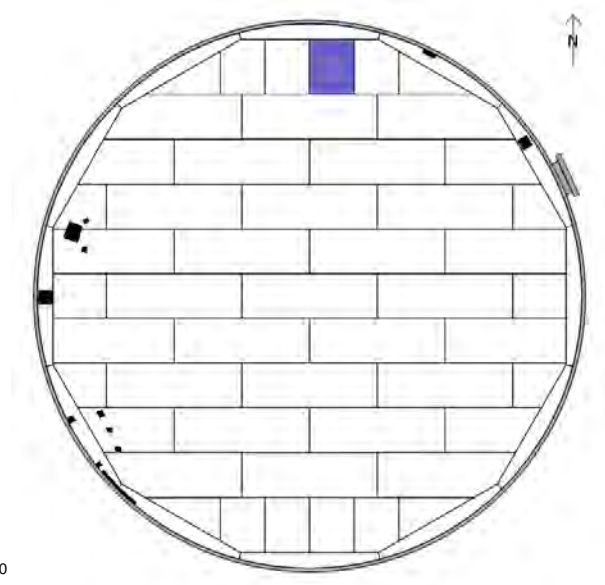
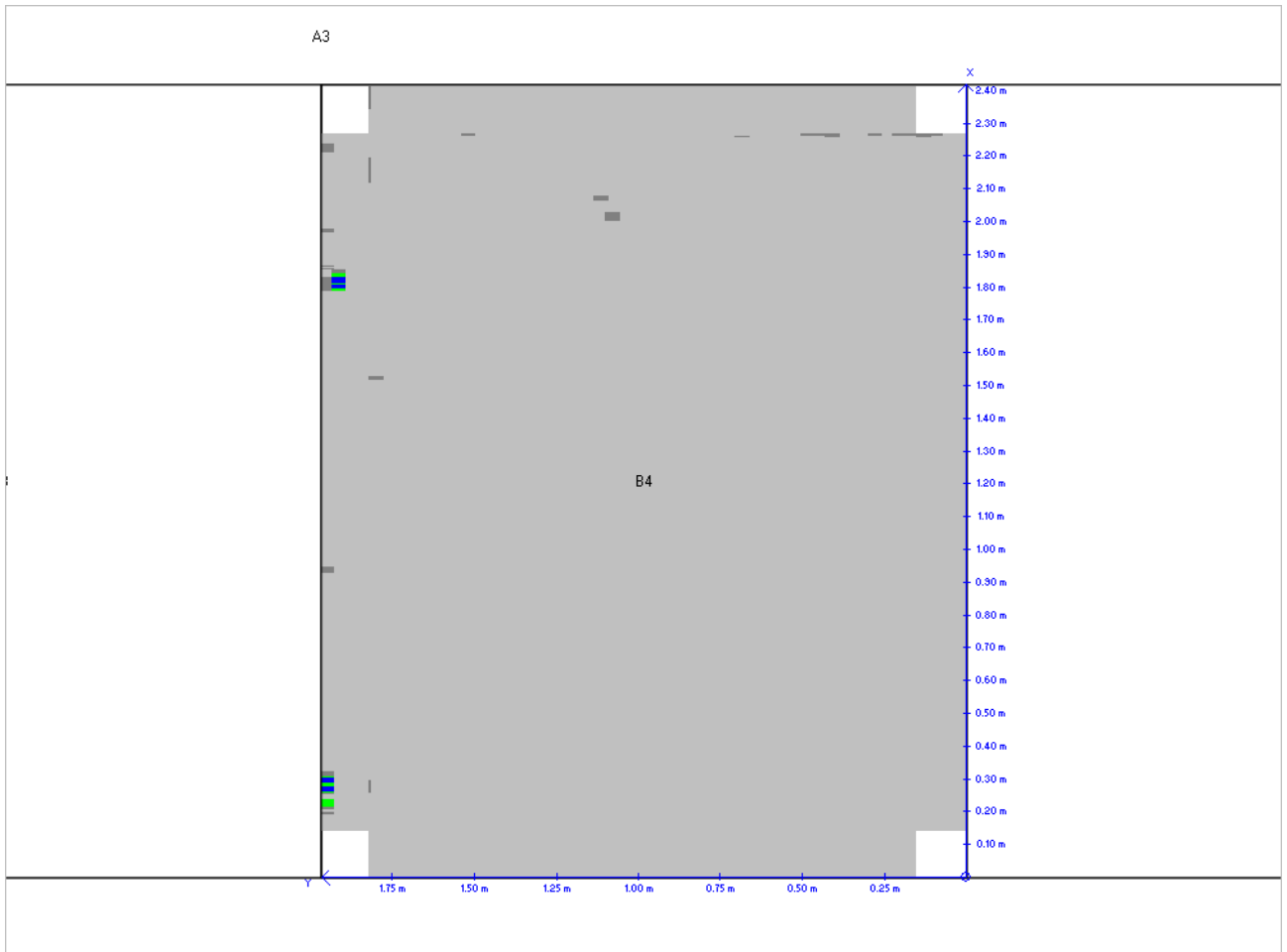

<ul style="list-style-type: none"> : Client a : Site b : 03/05/2016 : B 5 	<ul style="list-style-type: none"> : Tank 123 : K0xx-16 : Jxx86
---	--

Topside-Differential

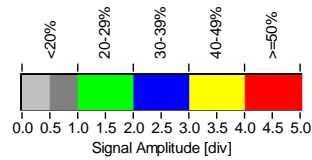
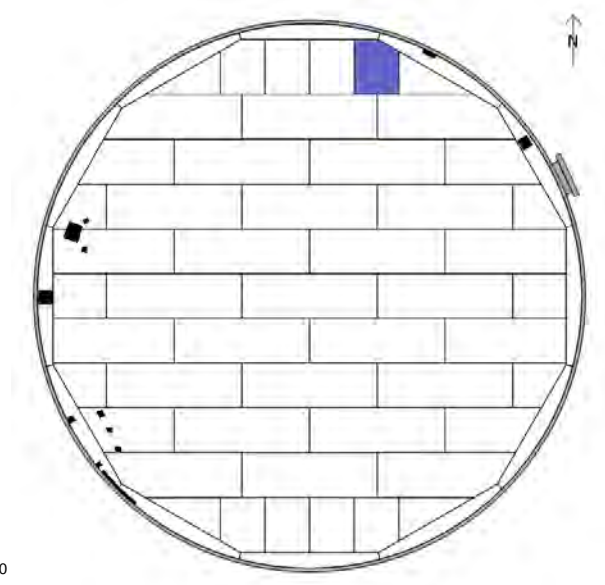
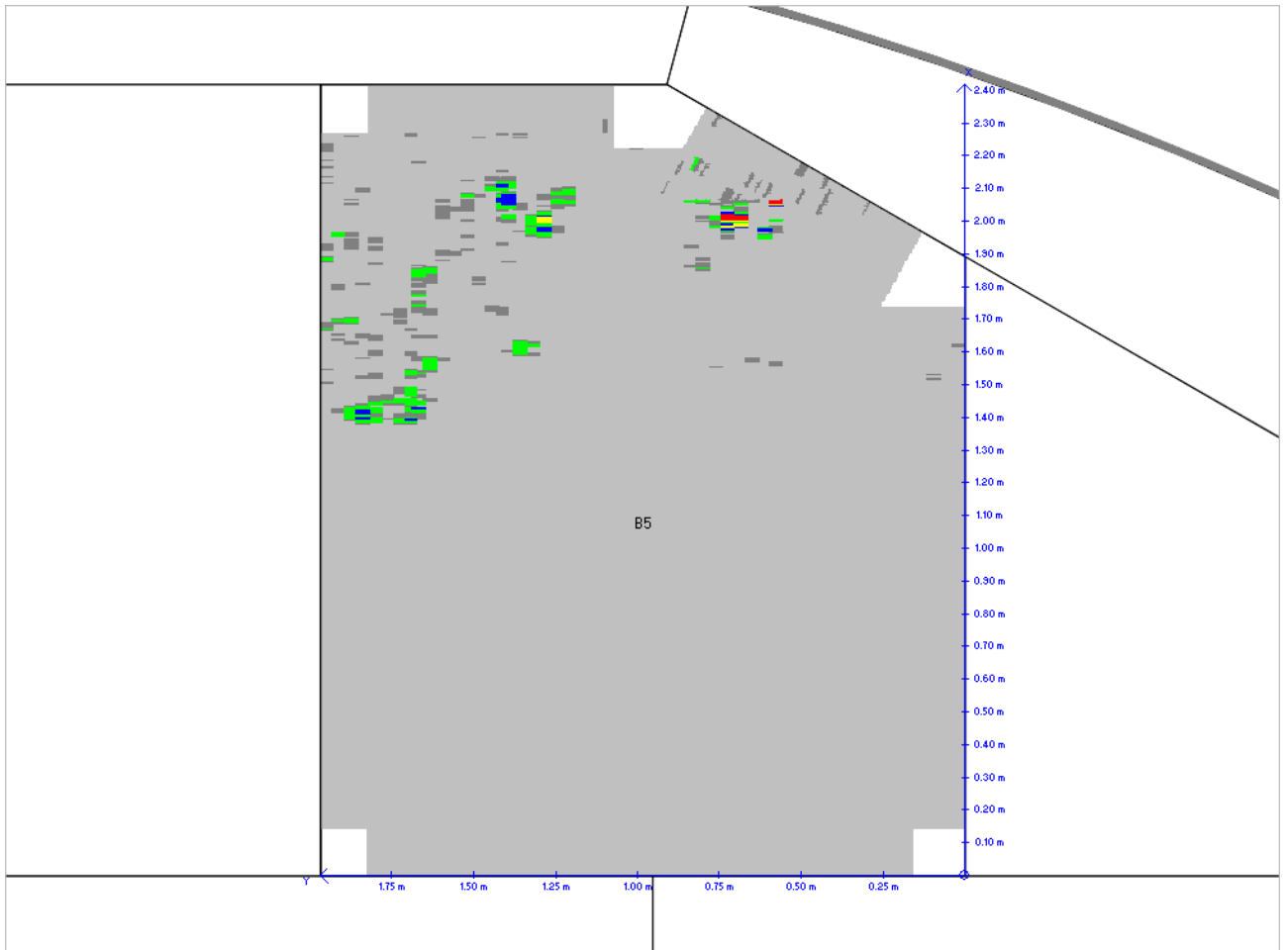

<ul style="list-style-type: none"> : Client a : Site b : 03/05/2016 : B 6 	<ul style="list-style-type: none"> : Tank 123 : K0xx-16 : Jxx86
---	--

Topside-Differential

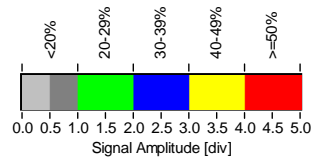
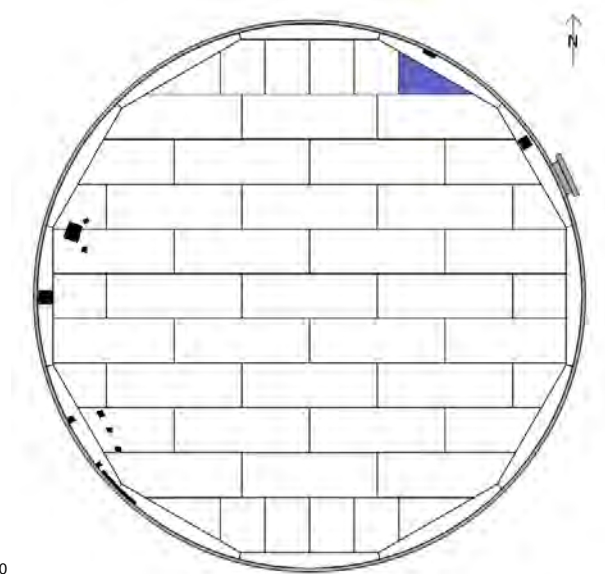
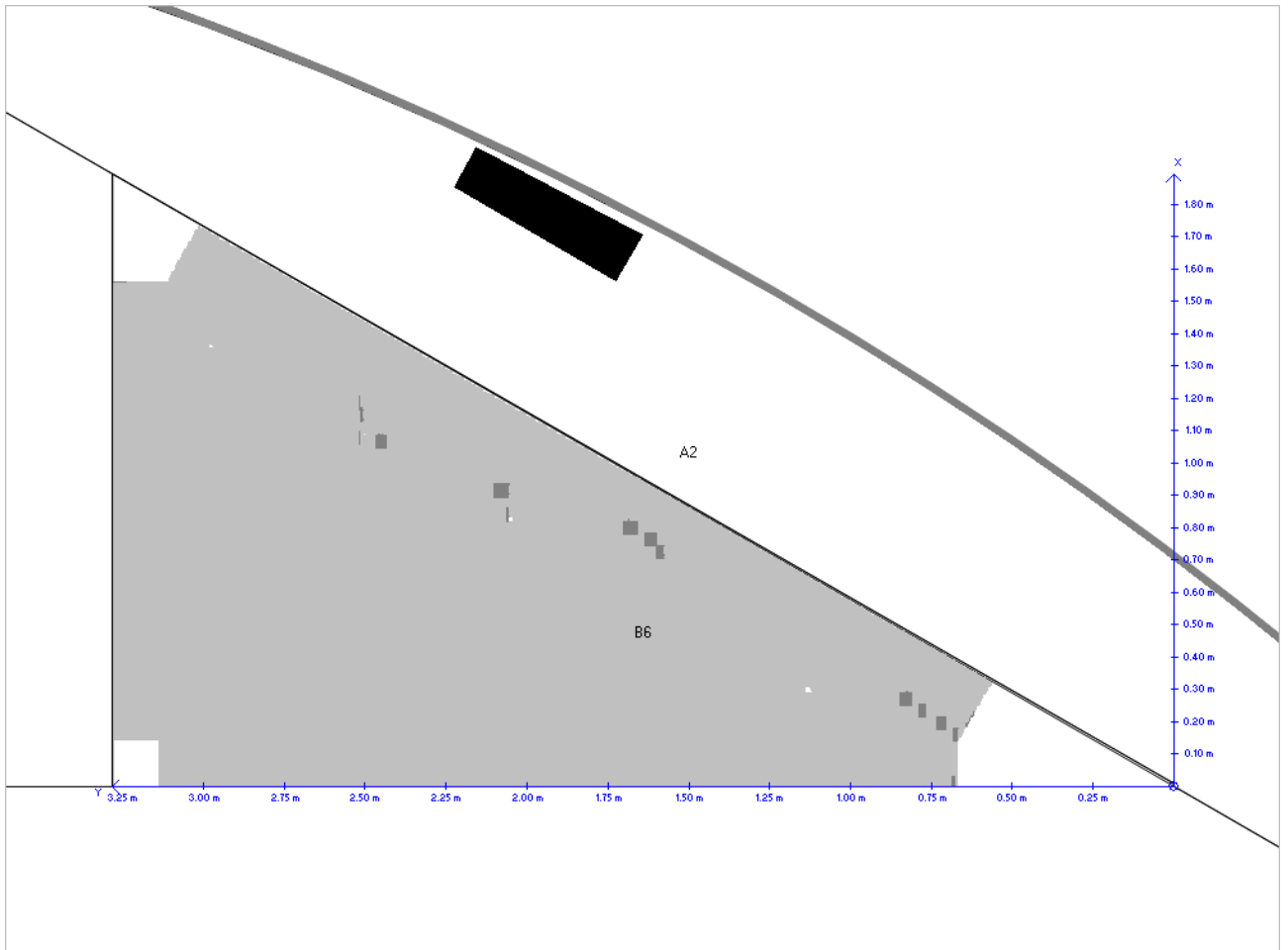

: Client a : Site b : 03/05/2016 : B 7	: Tank 123 : K0xx-16 : Jxx86
---	------------------------------------

Topside-Differential

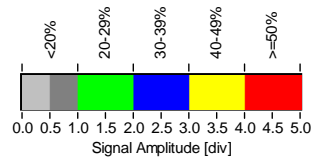
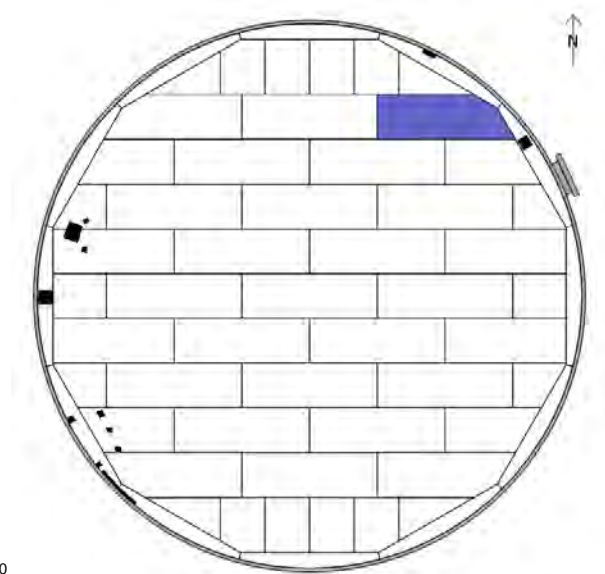
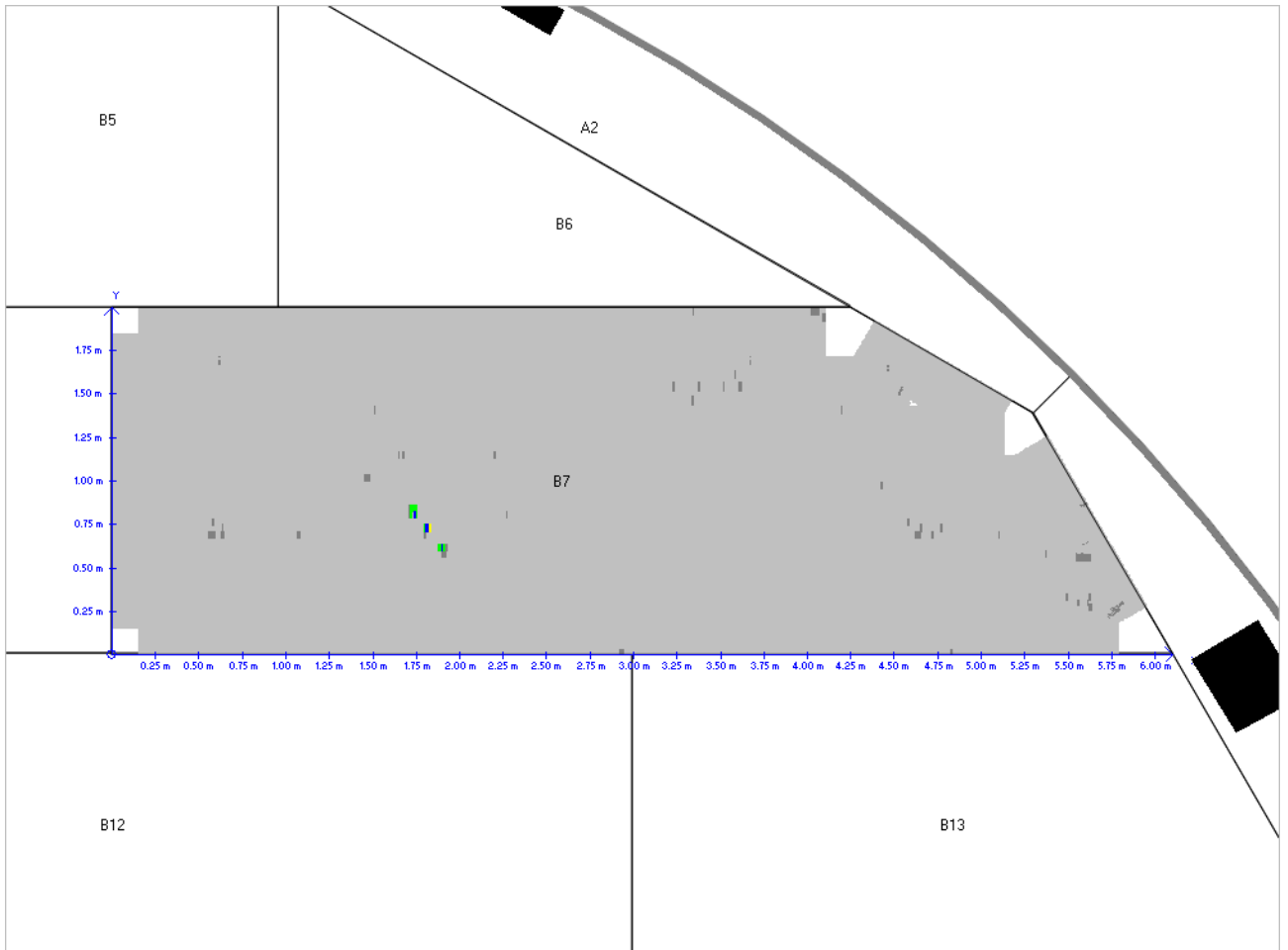

: Client a : Site b : 03/05/2016 : B 8	: Tank 123 : K0xx-16 : Jxx86
---	------------------------------------

Topside-Differential

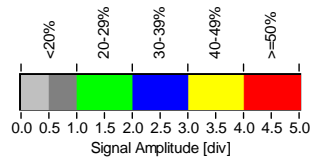
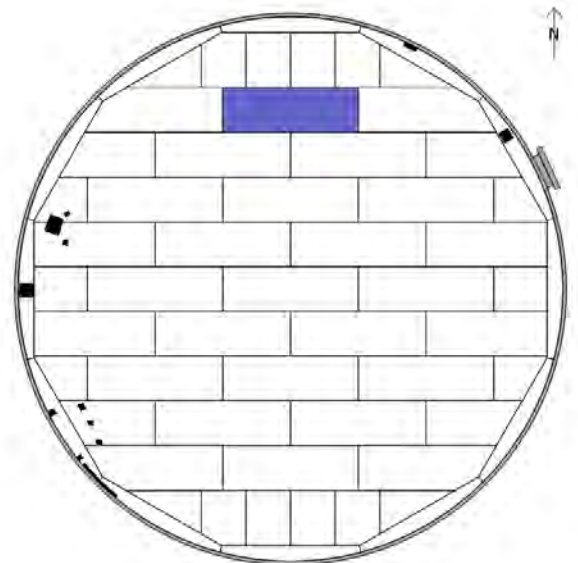
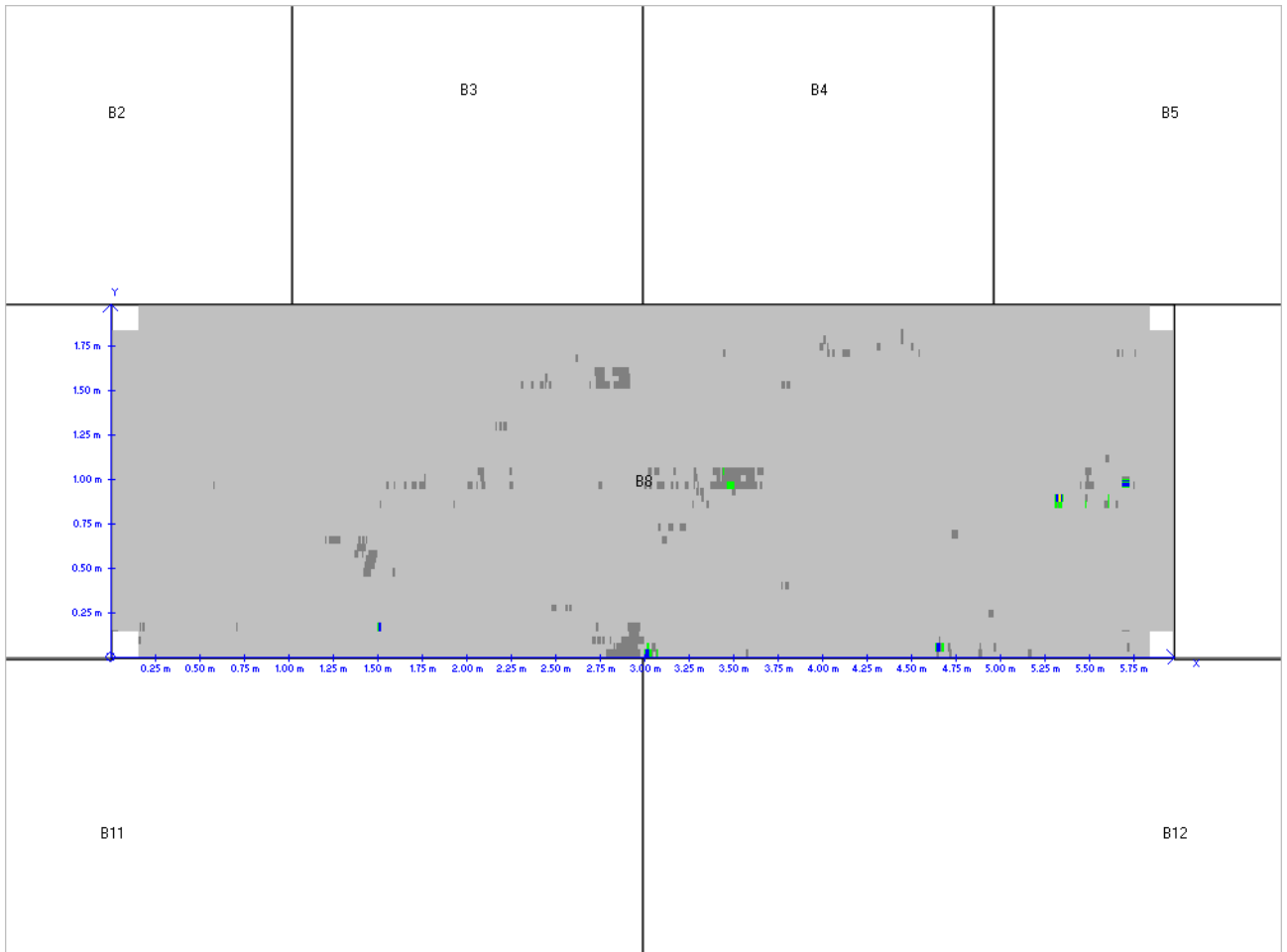

<ul style="list-style-type: none"> : Client a : Site b : 03/05/2016 : B 9 	<ul style="list-style-type: none"> : Tank 123 : K0xx-16 : Jxx86
---	--

Topside-Differential

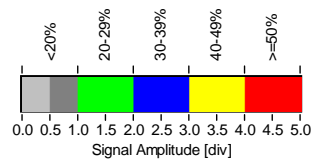
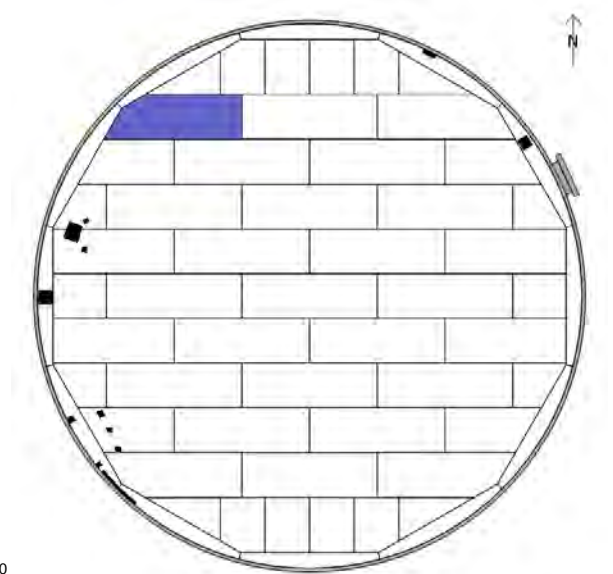
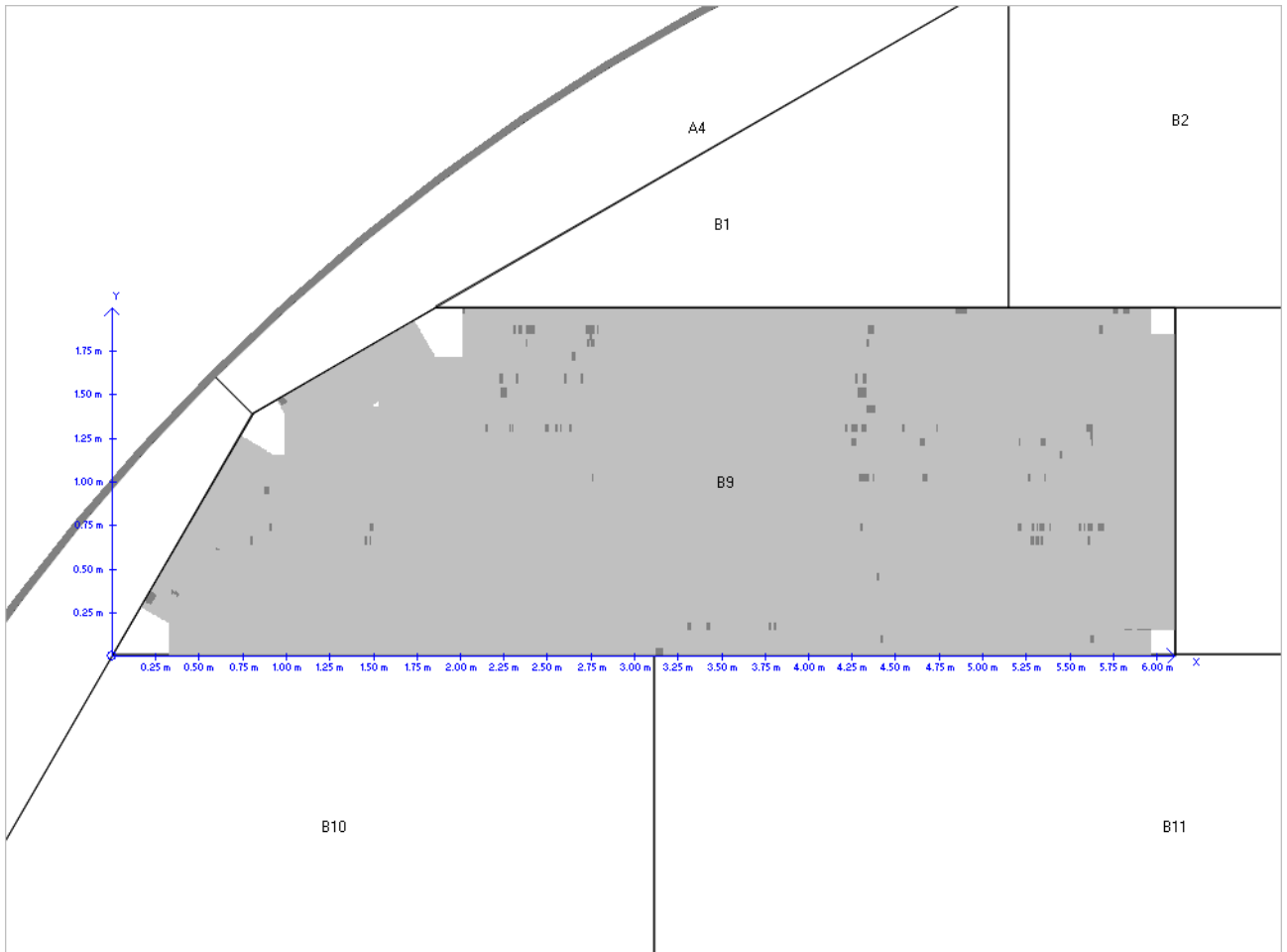

<ul style="list-style-type: none"> : Client a : Site b : 03/05/2016 : B 10 	<ul style="list-style-type: none"> : Tank 123 : K0xx-16 : Jxx86
--	--

Topside-Differential

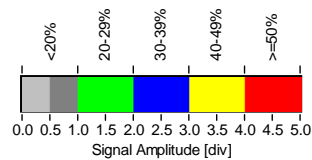
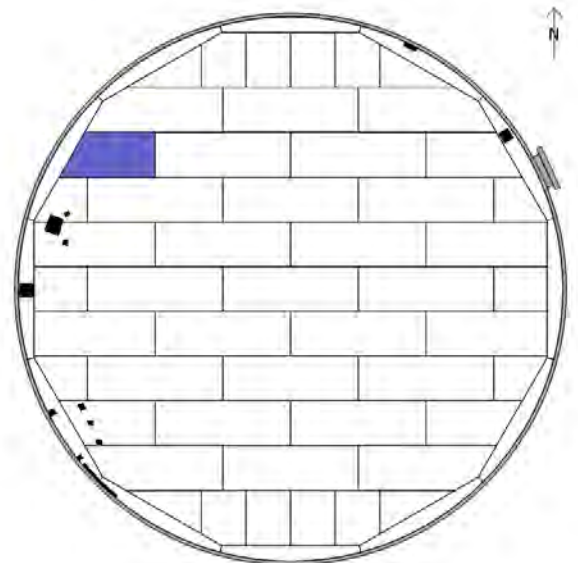
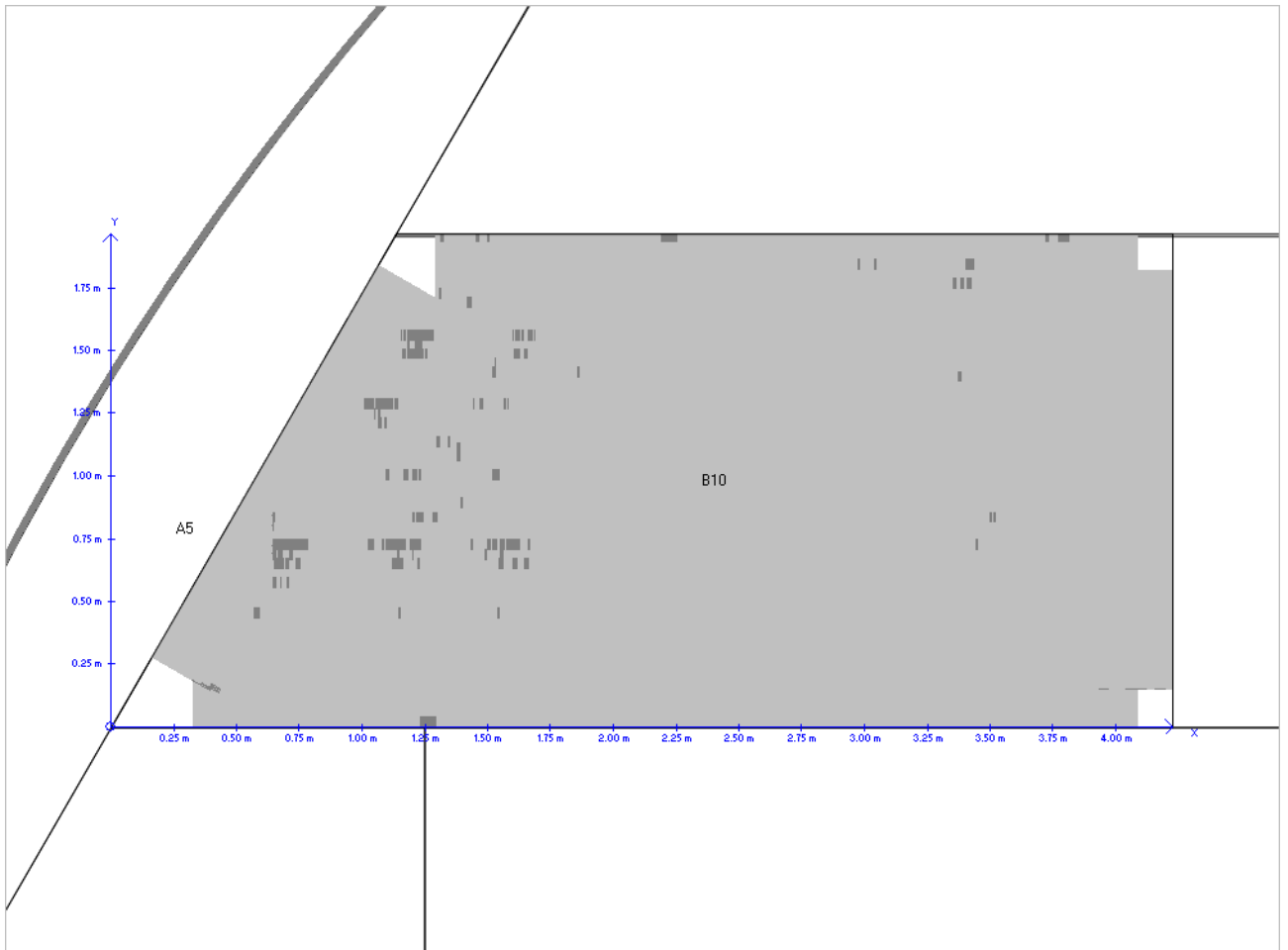

: Client a : Site b : 03/05/2016 : B 11	: Tank 123 : K0xx-16 : Jxx86
--	------------------------------------

Topside-Differential

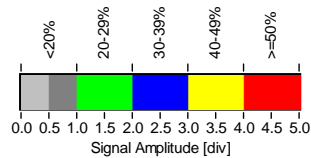
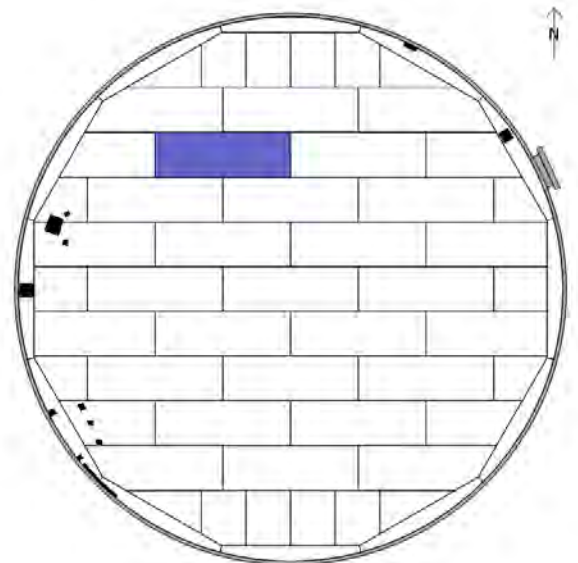
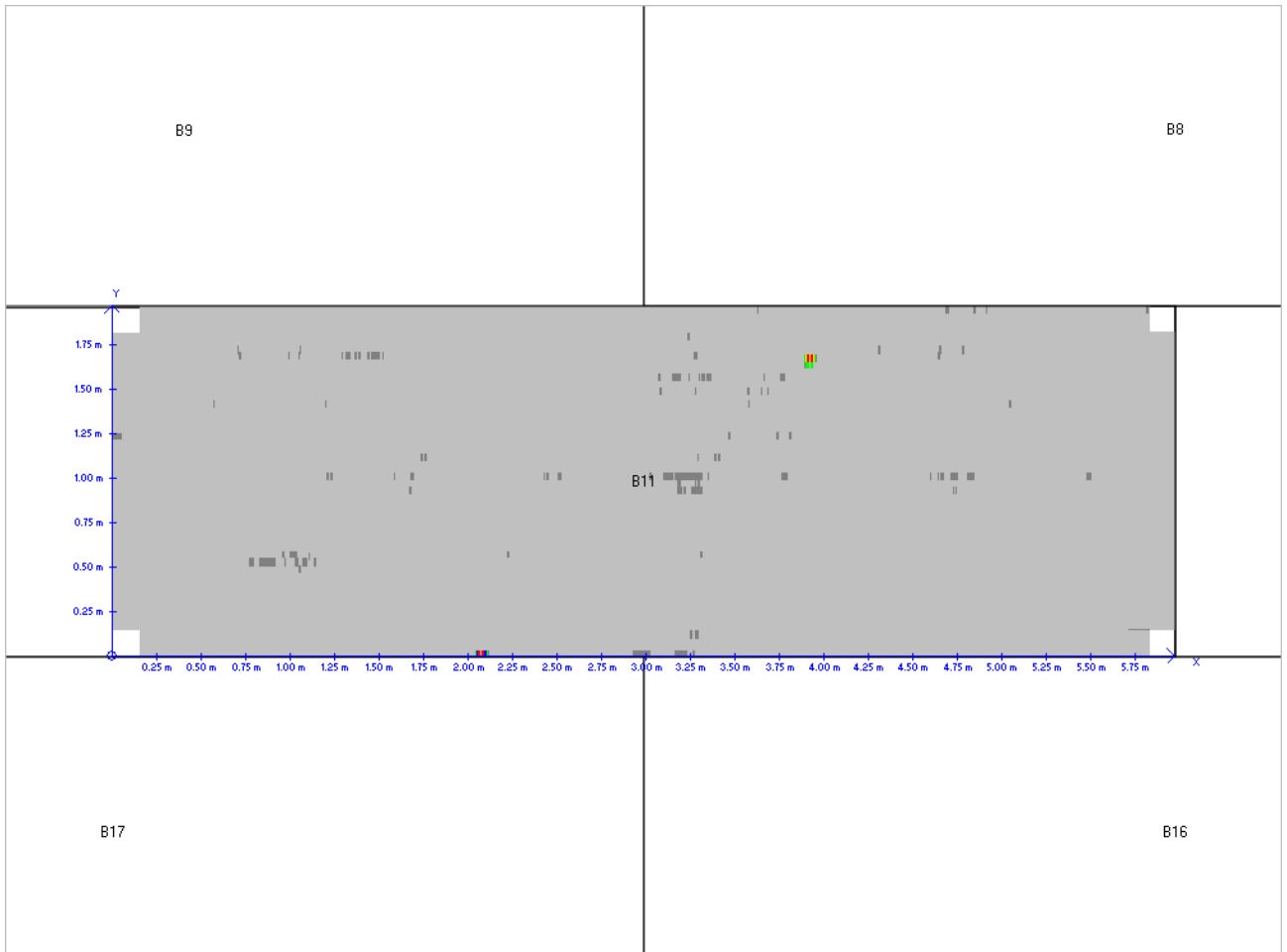

: Client a : Site b : 03/05/2016 : B 12	: Tank 123 : K0xx-16 : Jxx86
--	------------------------------------

Topside-Differential

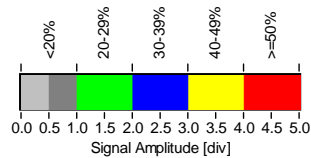
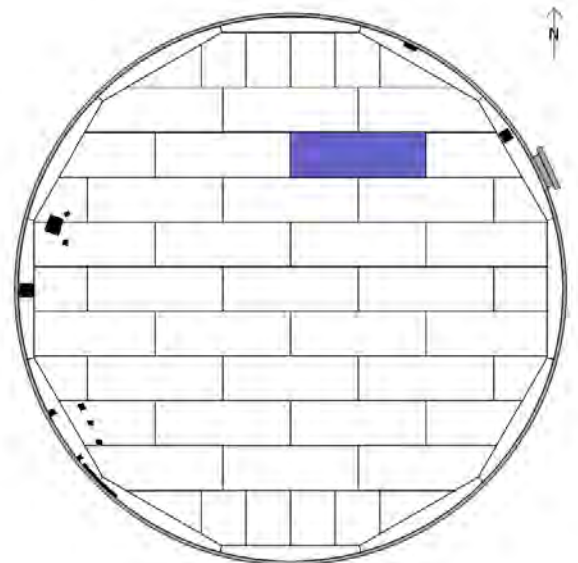
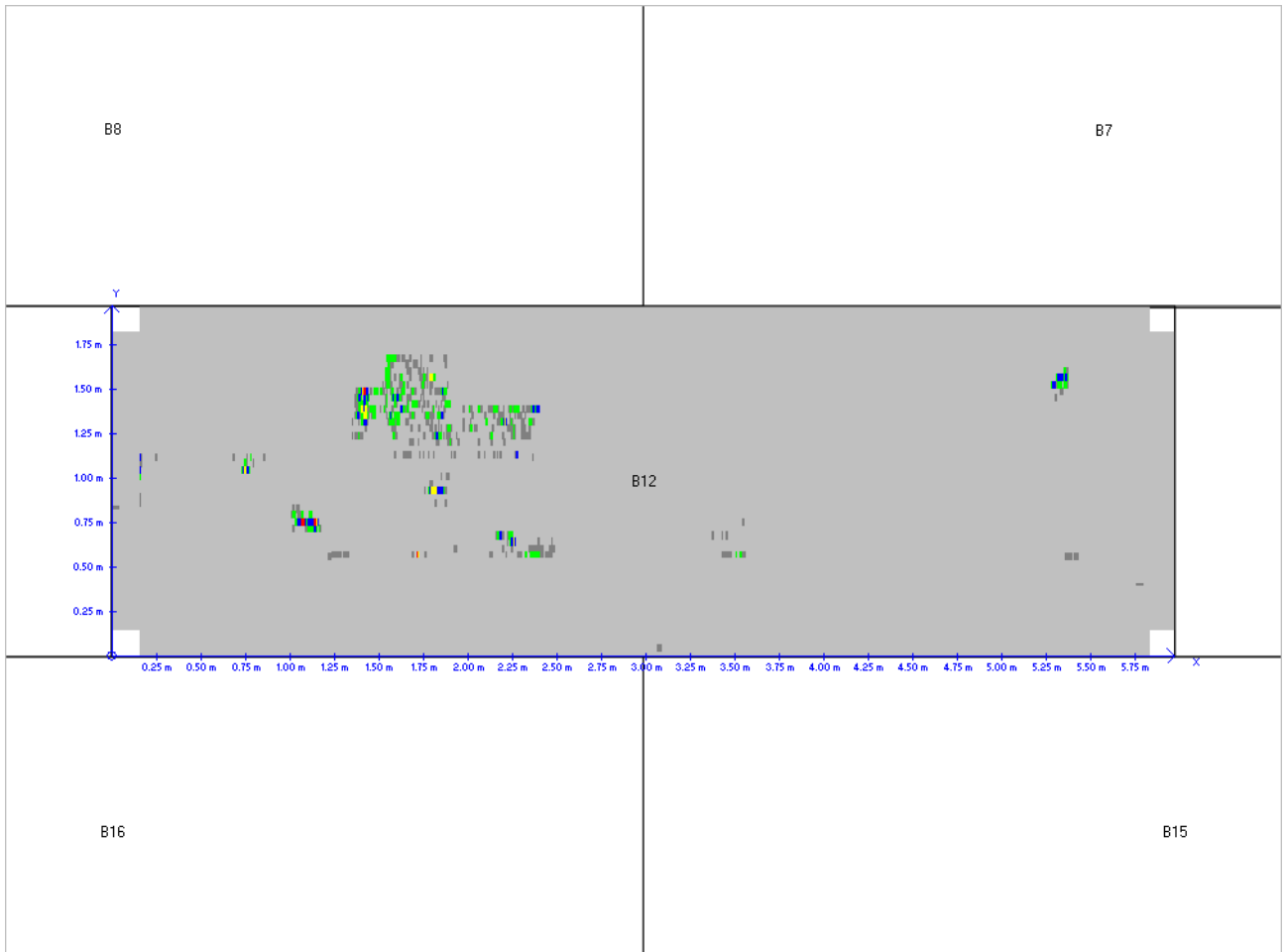

: Client a : Site b : 03/05/2016 : B 13	: Tank 123 : K0xx-16 : Jxx86
--	------------------------------------

Topside-Differential

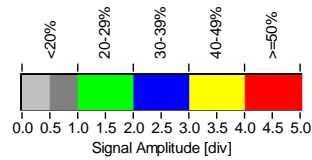
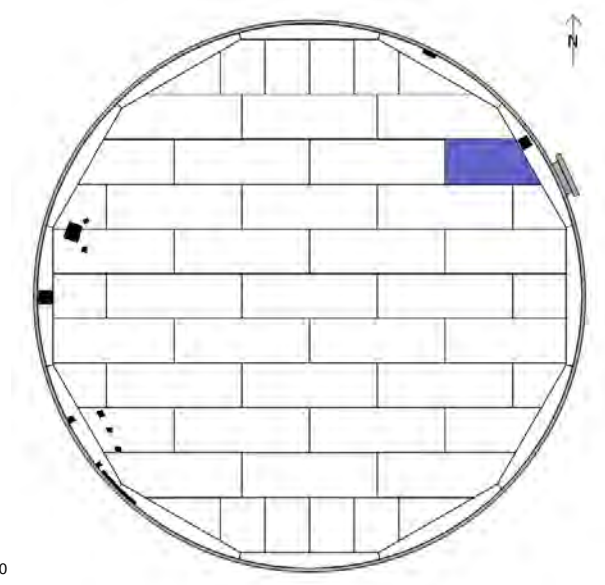
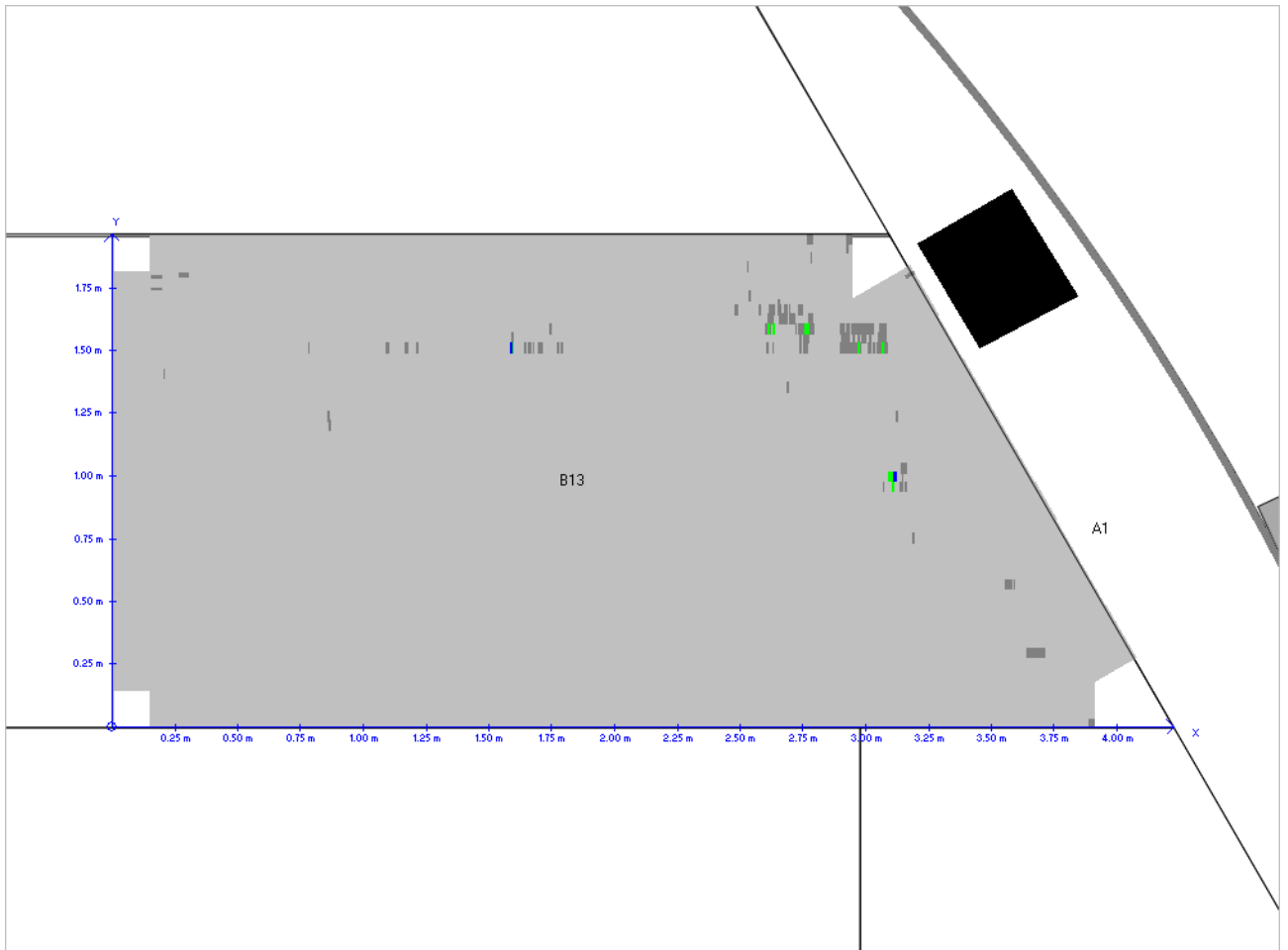

<ul style="list-style-type: none"> : Client a : Site b : 03/05/2016 : B 14 	<ul style="list-style-type: none"> : Tank 123 : K0xx-16 : Jxx86
--	--

Topside-Differential

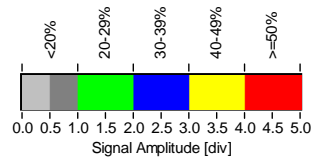
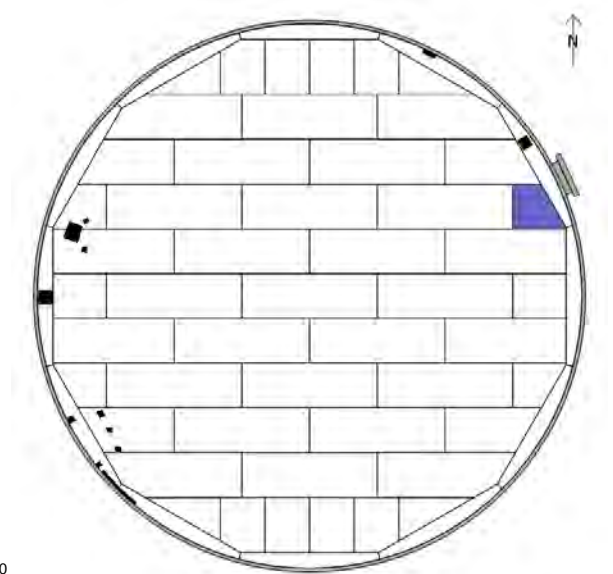
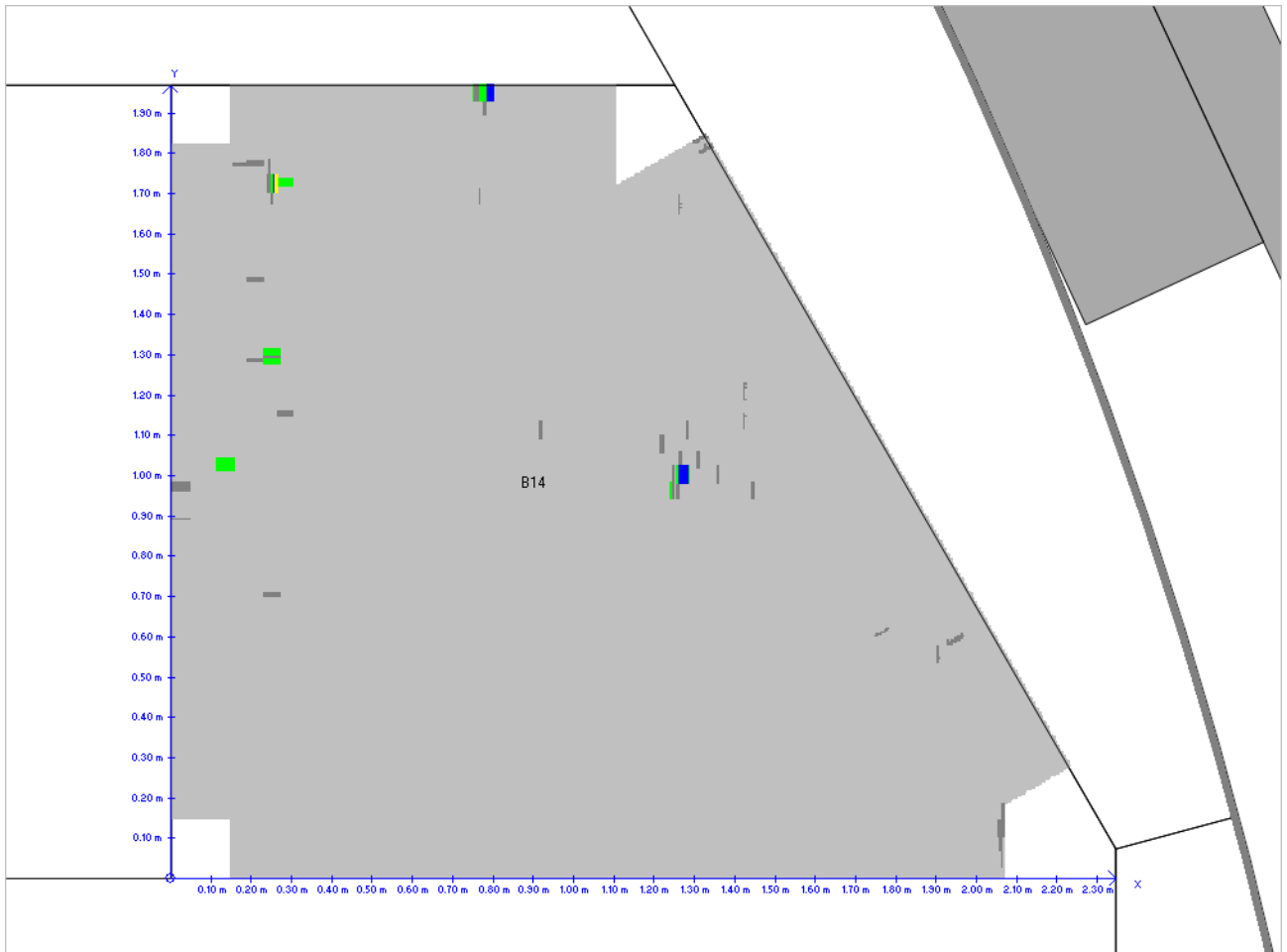

: Client a : Site b : 03/05/2016 : B 15	: Tank 123 : K0xx-16 : Jxx86
--	------------------------------------

Topside-Differential

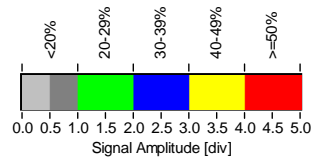
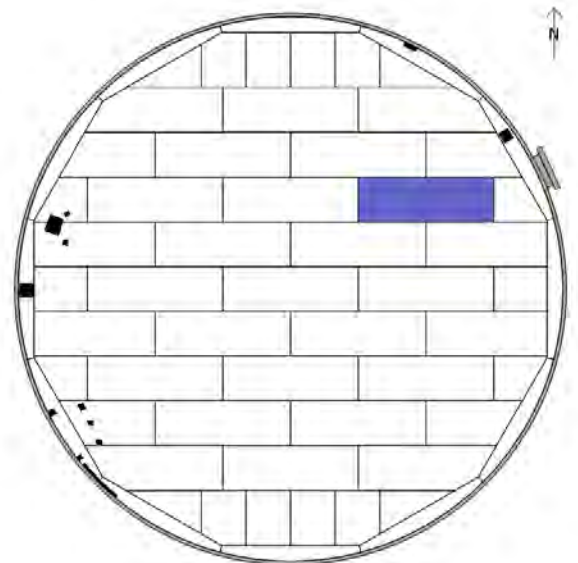
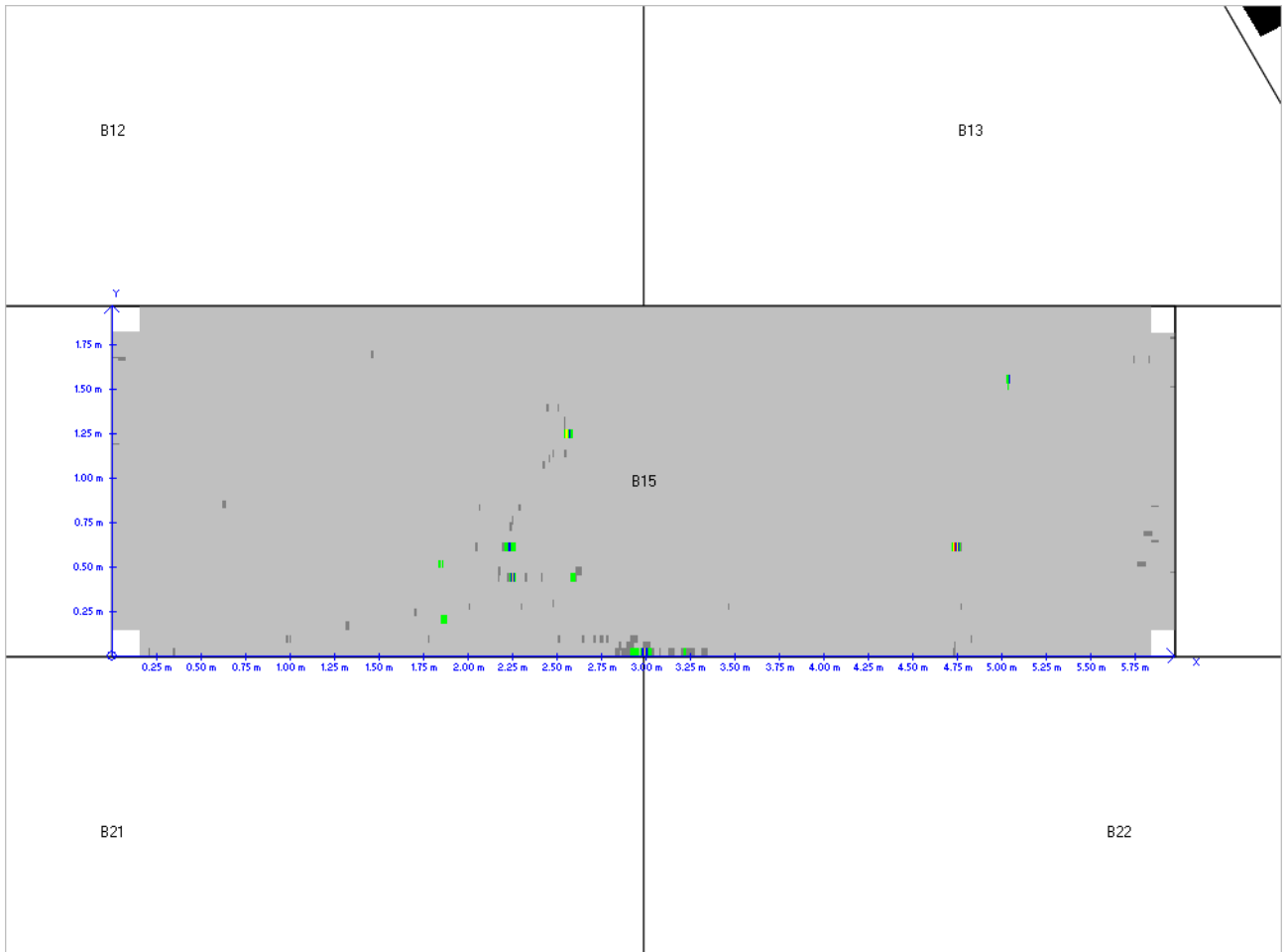

<ul style="list-style-type: none"> : Client a : Site b : 03/05/2016 : B 16 	<ul style="list-style-type: none"> : Tank 123 : K0xx-16 : Jxx86
--	--

Topside-Differential

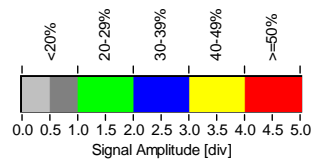
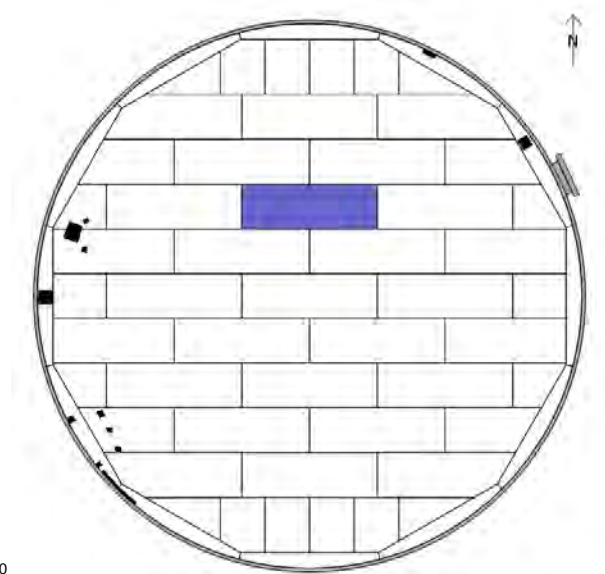
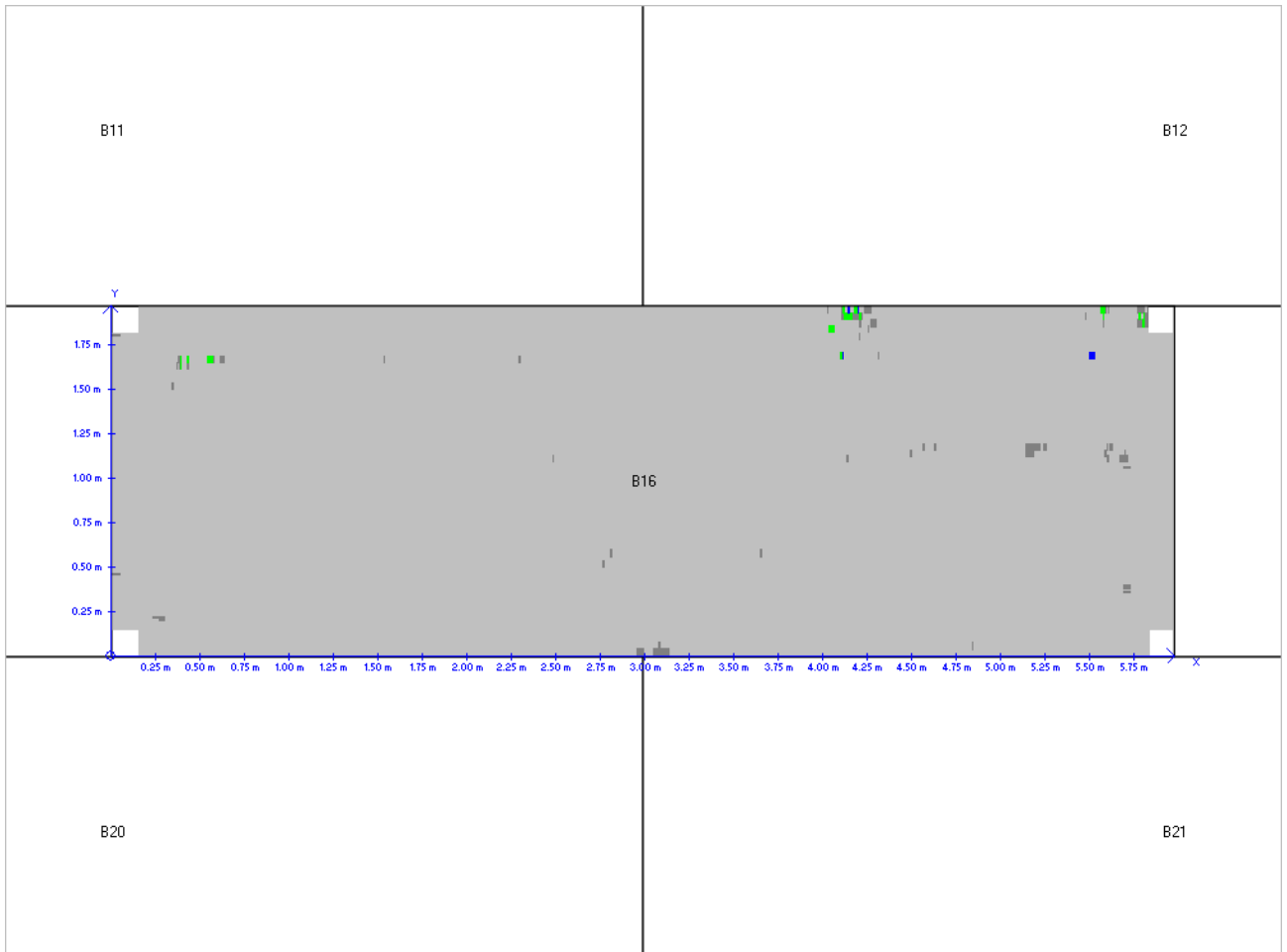

: Client a : Site b : 03/05/2016 : B 17	: Tank 123 : K0xx-16 : Jxx86
--	------------------------------------

Topside-Differential

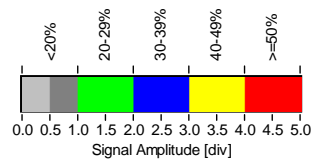
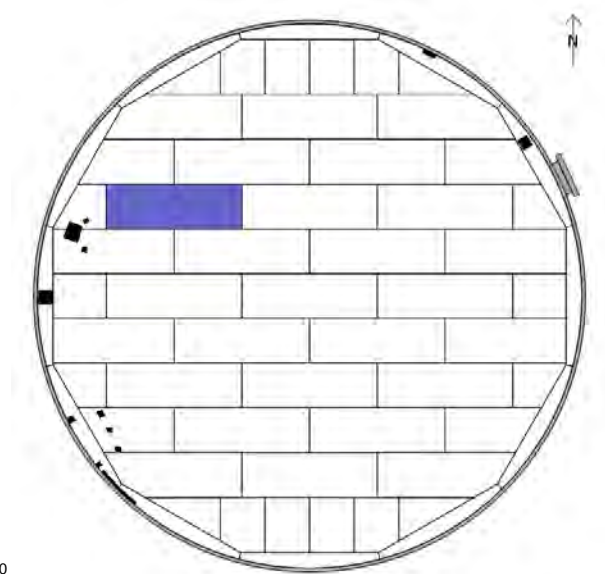
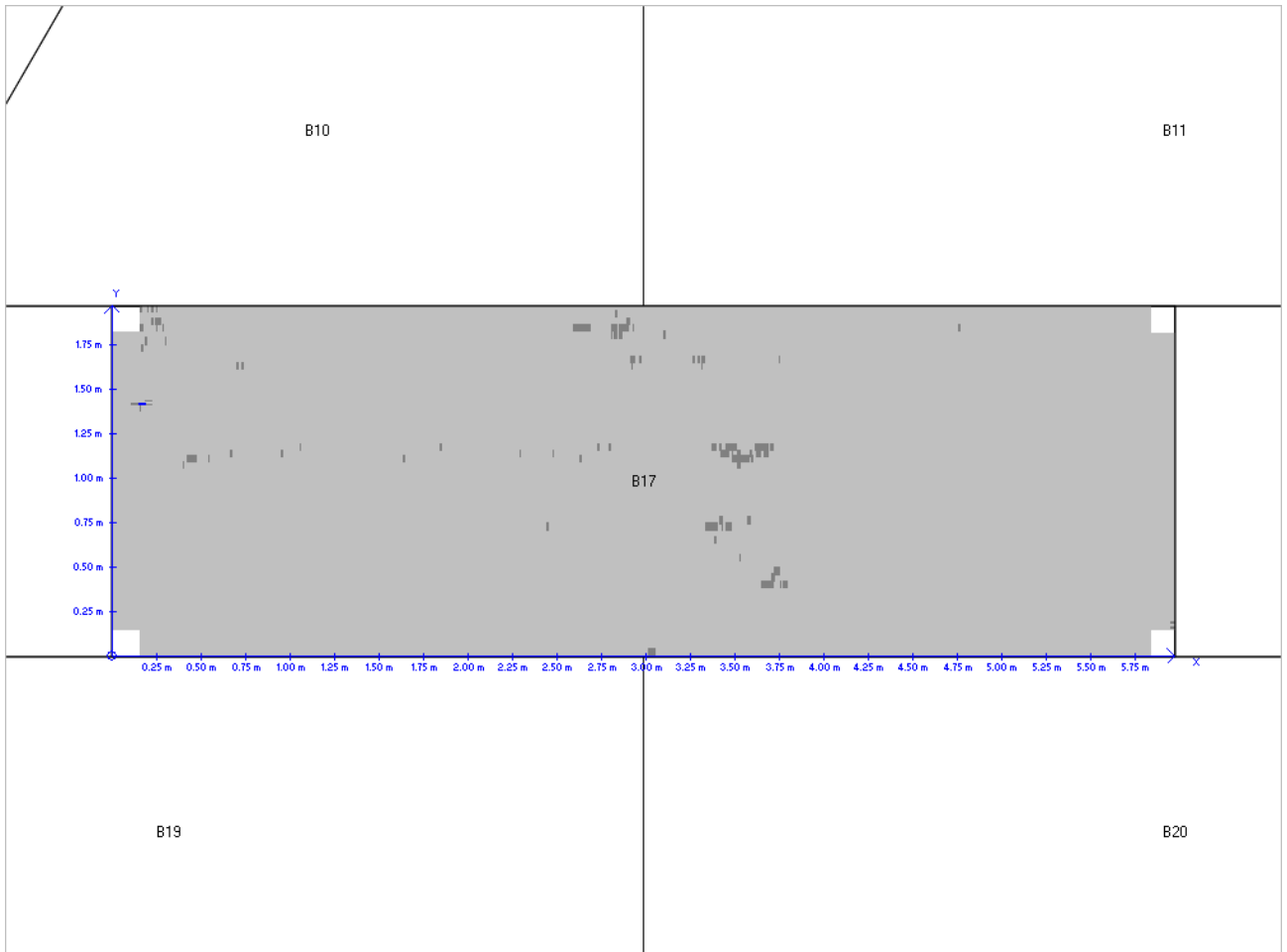

<ul style="list-style-type: none"> : Client a : Site b : 03/05/2016 : B 18 	<ul style="list-style-type: none"> : Tank 123 : K0xx-16 : Jxx86
--	--

Topside-Differential

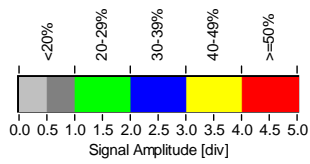
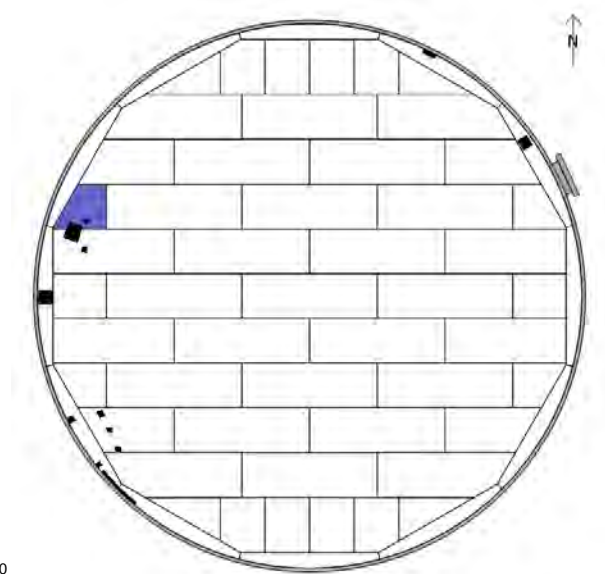
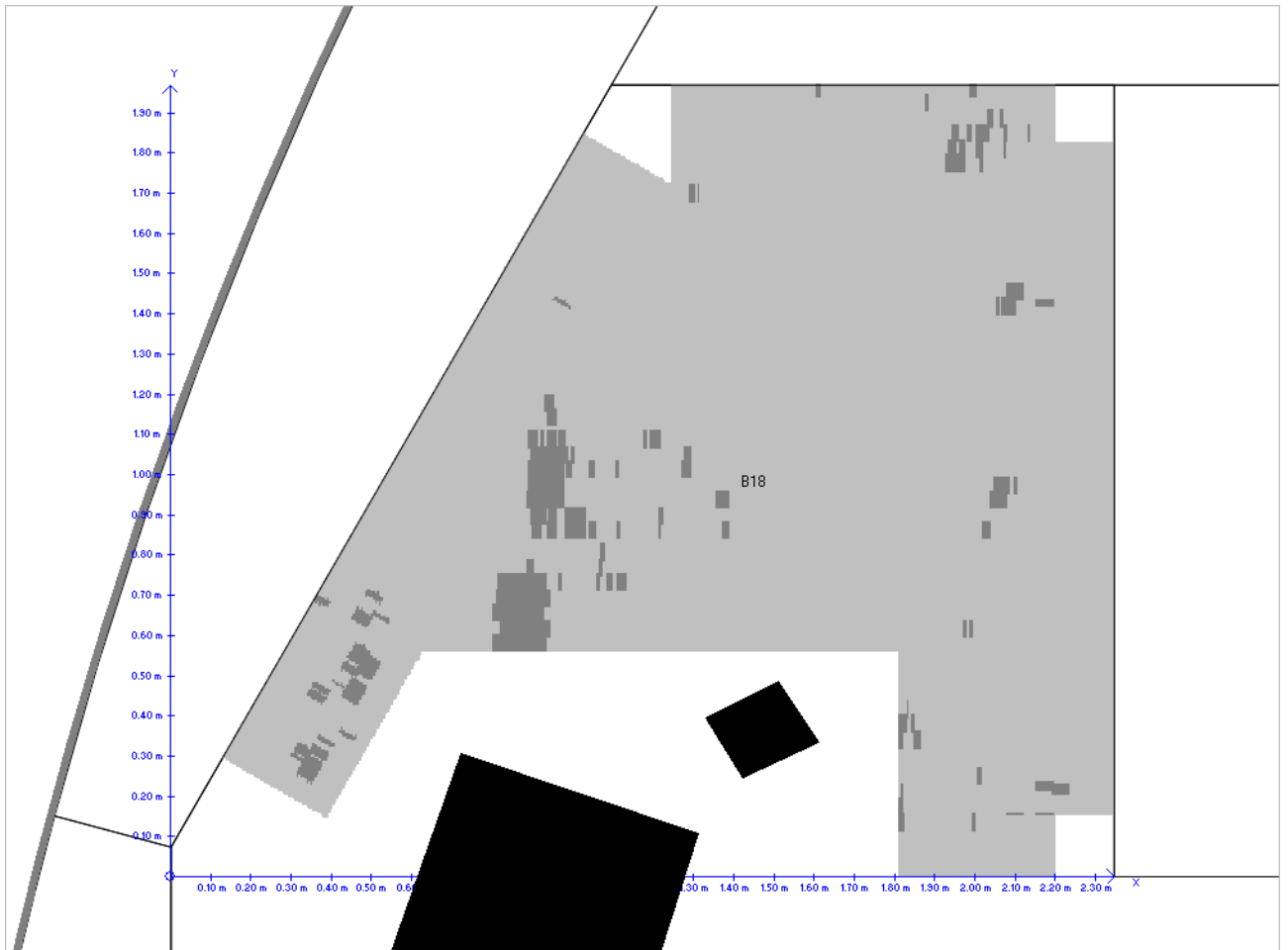

: Client a : Site b : 03/05/2016 : B 19	: Tank b : K0xx-16 : Jxx86
--	----------------------------------

Topside-Differential

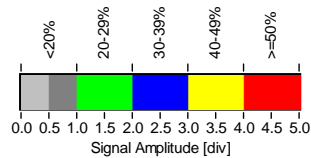
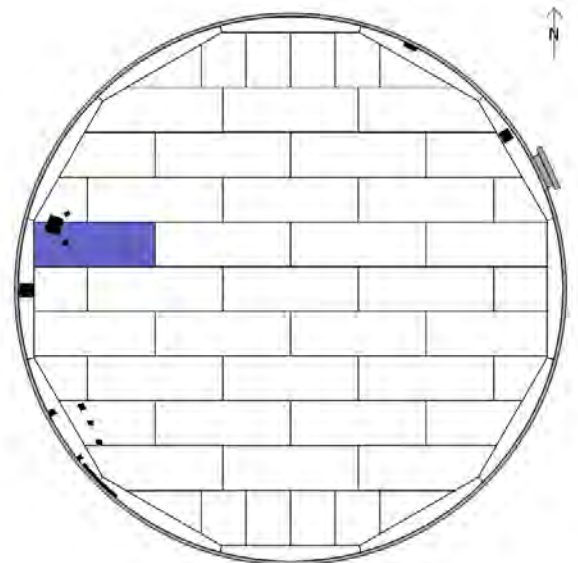
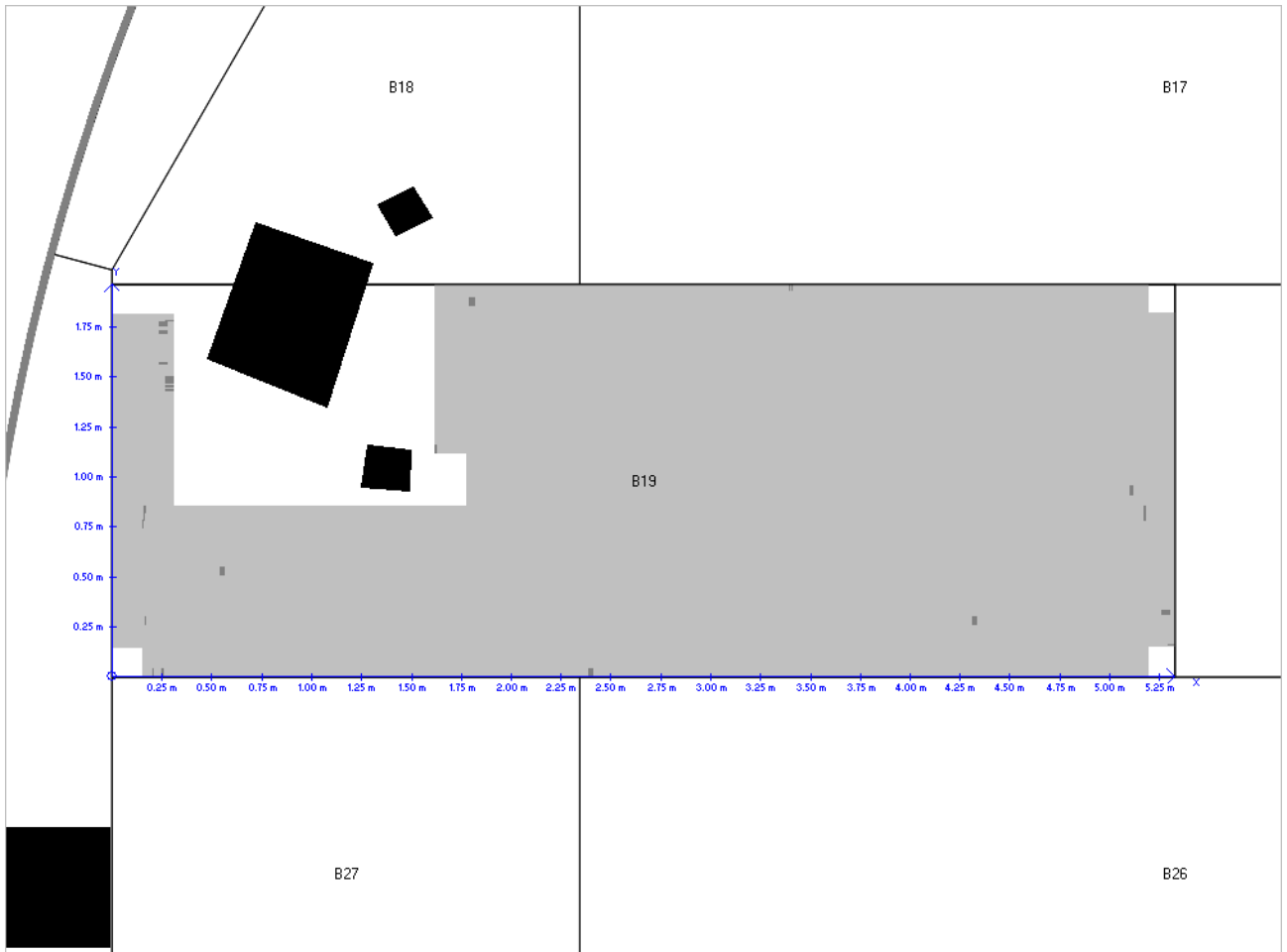

: Client a : Site b : 03/05/2016 : B 20	: Tank 123 : K0xx-16 : Jxx86
--	------------------------------------

Topside-Differential

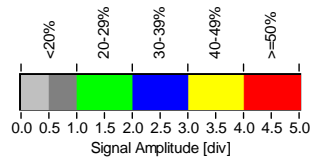
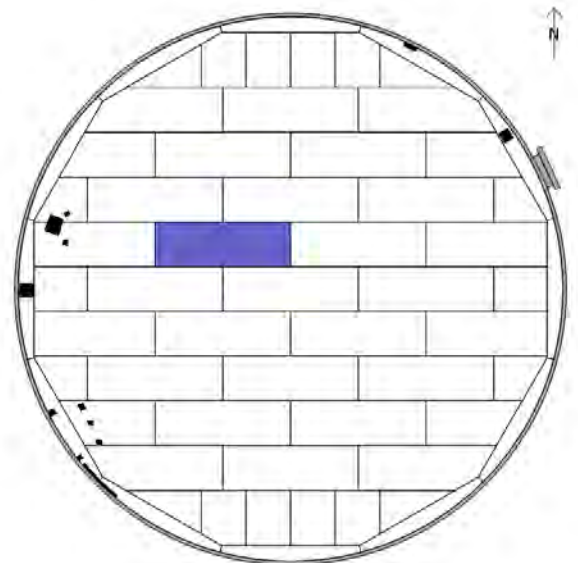
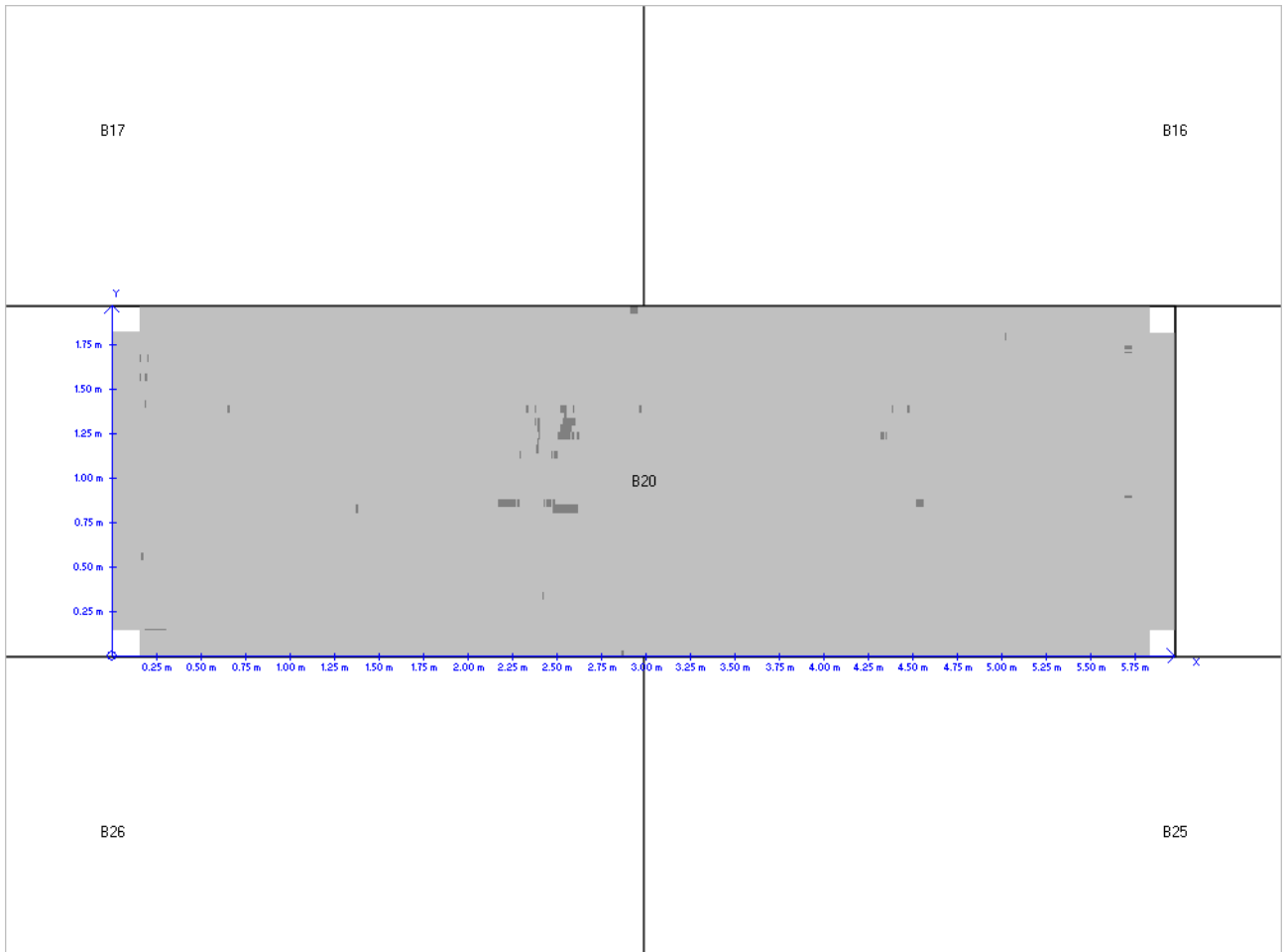

: Client a : Site b : 03/05/2016 : B 21	: Tank 123 : K0xx-16 : Jxx86
--	------------------------------------

Topside-Differential

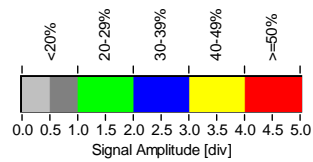
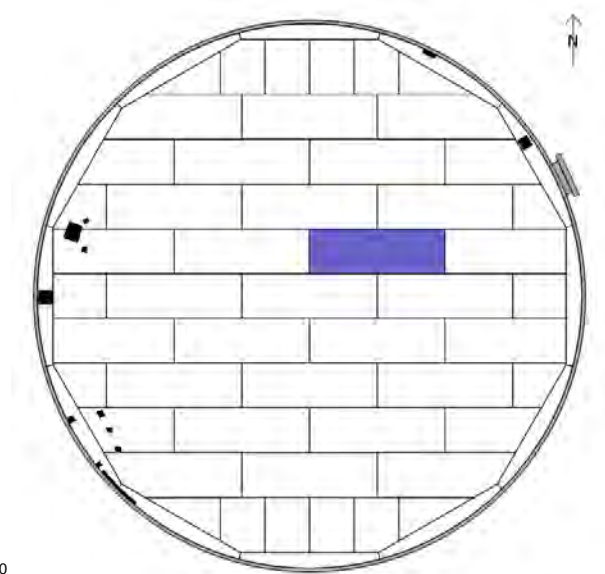
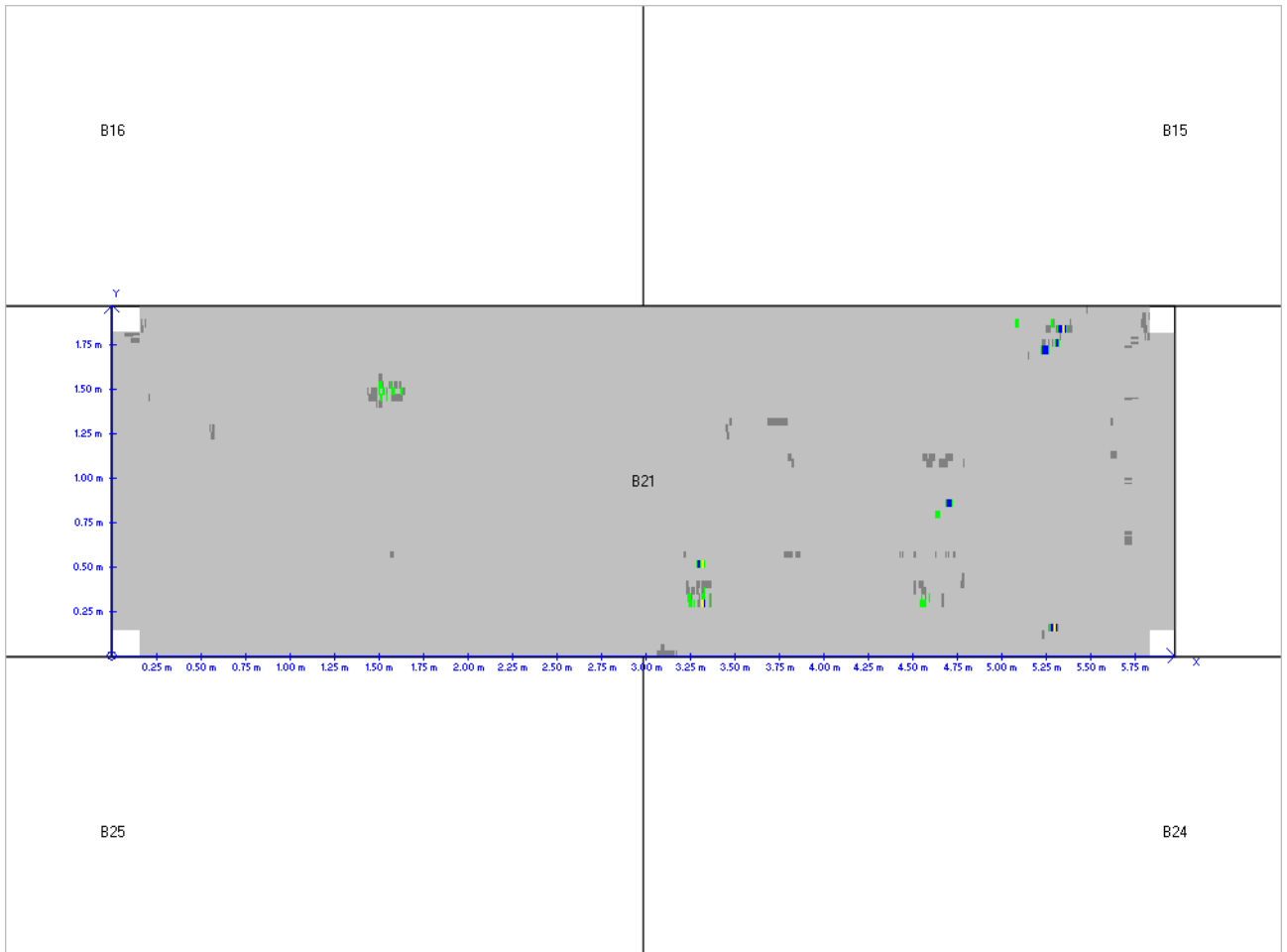

: Client a : Site b : 03/05/2016 : B 22	: Tank 123 : K0xx-16 : Jxx86
--	------------------------------------

Topside-Differential

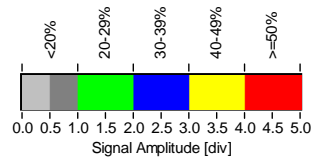
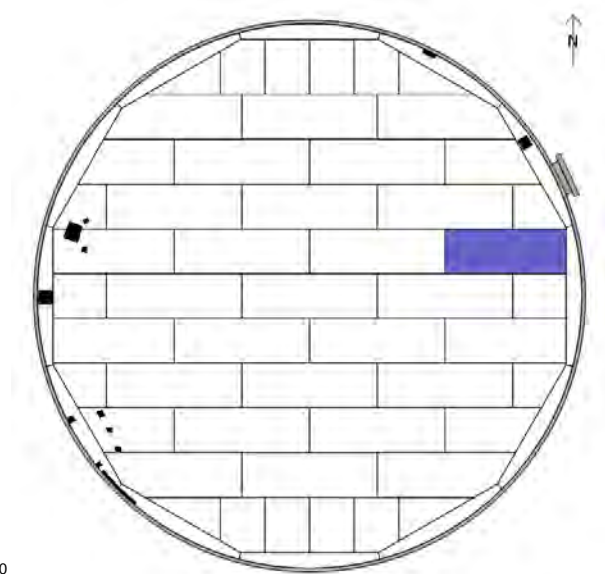
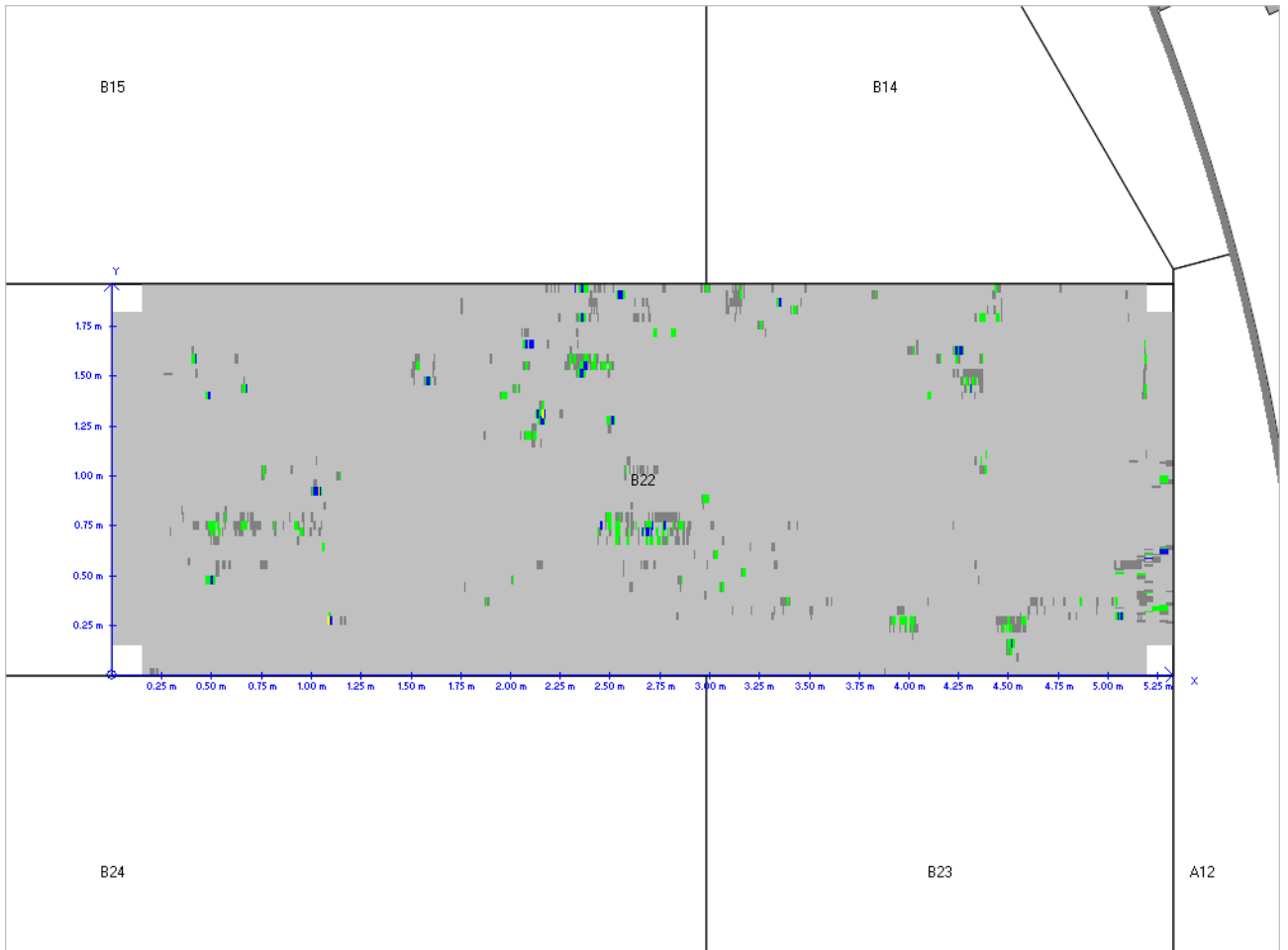

<ul style="list-style-type: none"> : Client a : Site b : 03/05/2016 : B 23 	<ul style="list-style-type: none"> : Tank 123 : K0xx-16 : Jxx86
--	--

Topside-Differential

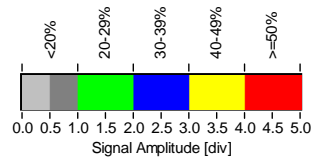
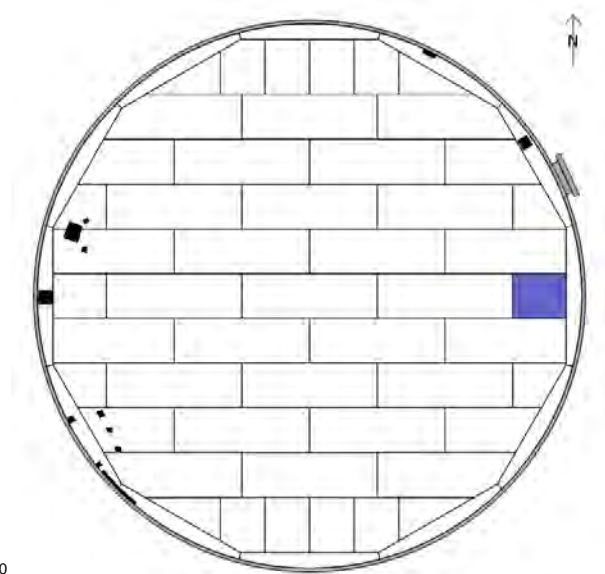
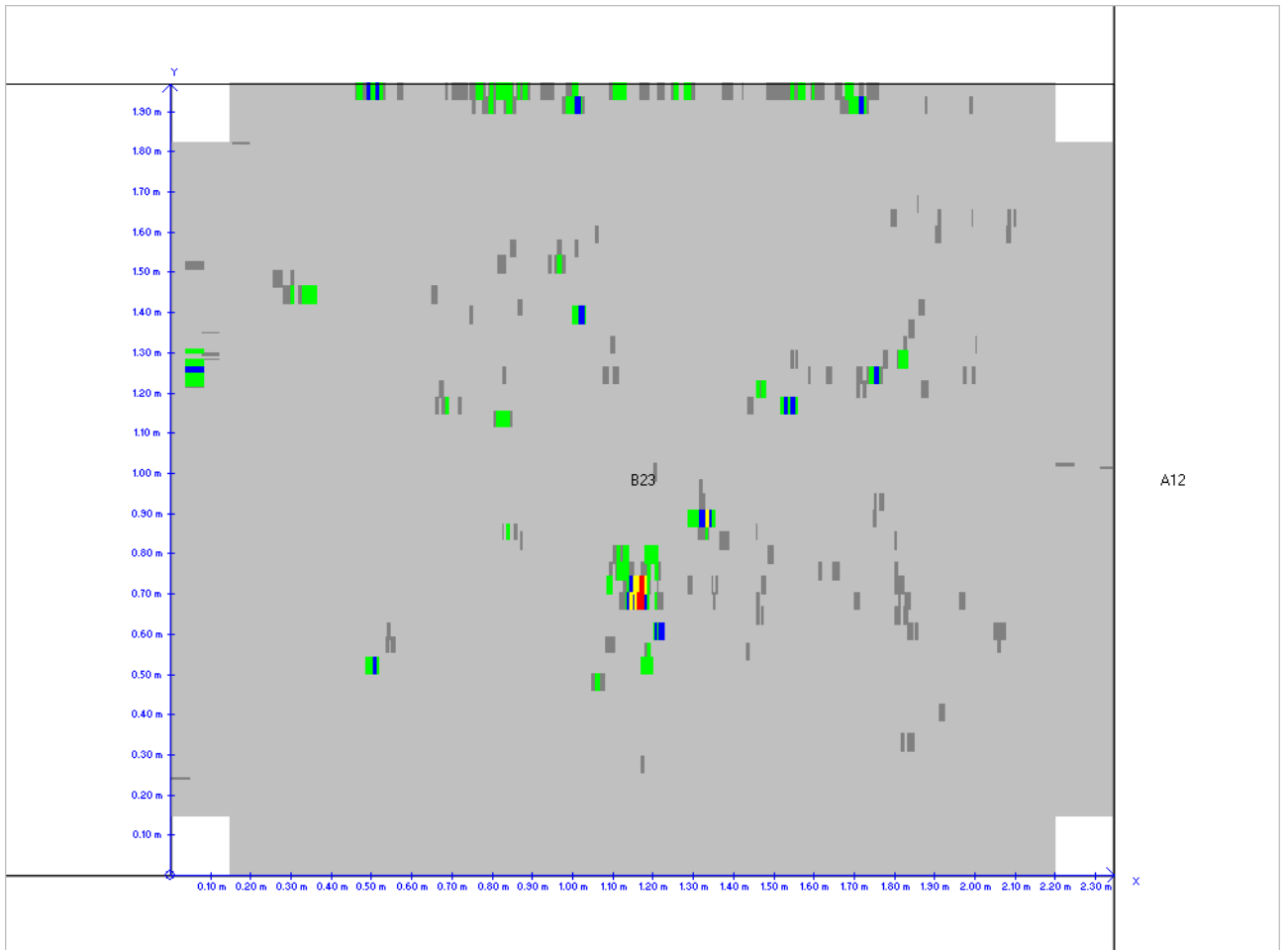

: Client a : Site b : 03/05/2016 : B 24	: Tank 123 : K0xx-16 : Jxx86
--	------------------------------------

Topside-Differential

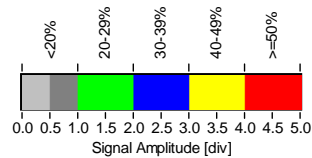
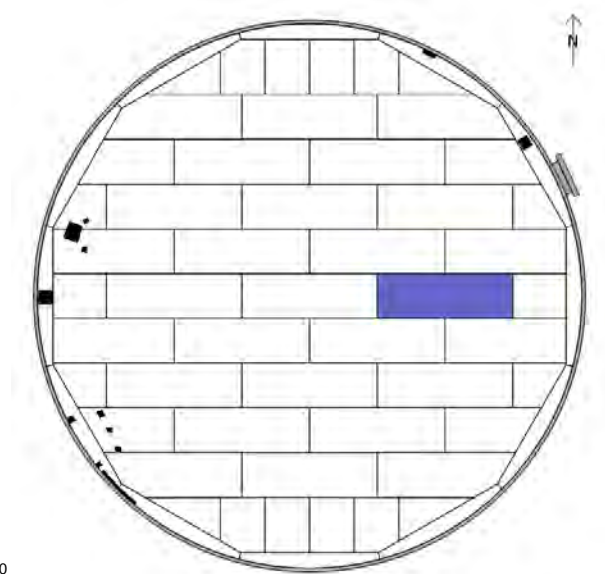
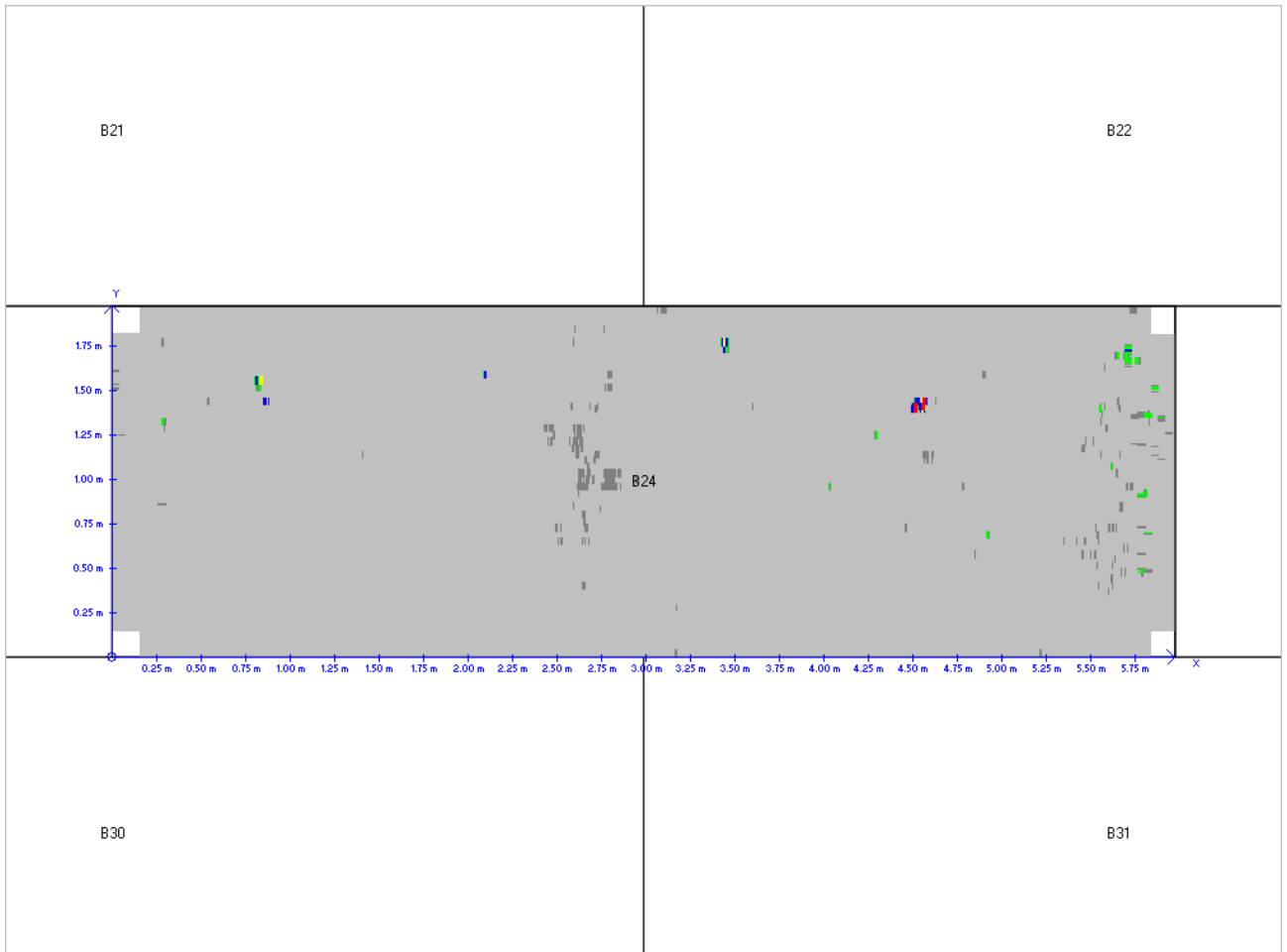

: Client a : Site b : 03/05/2016 : B 25	: Tank 123 : K0xx-16 : Jxx86
--	------------------------------------

Topside-Differential

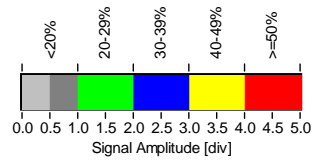
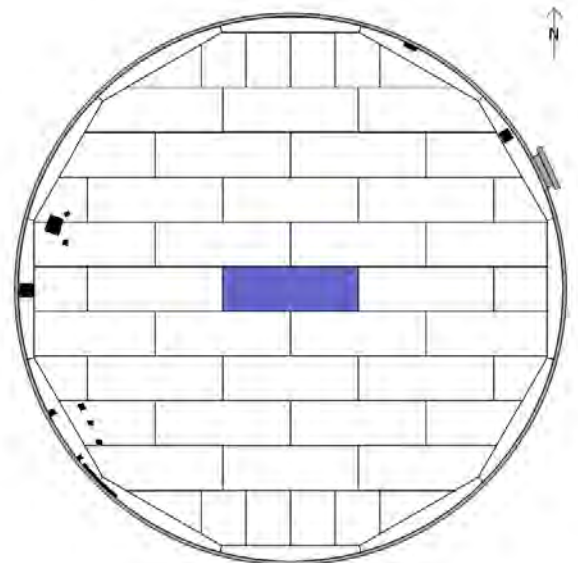
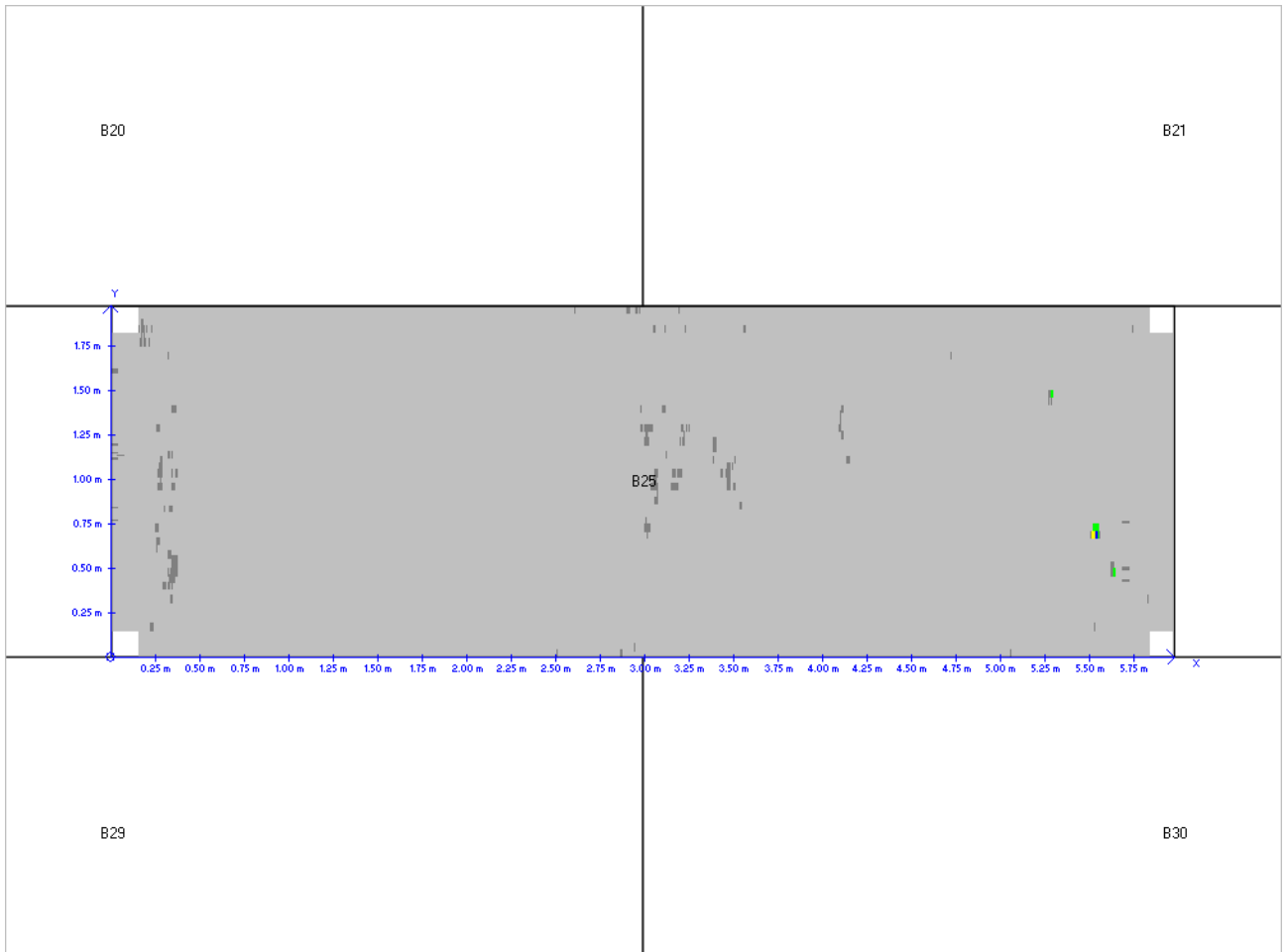

: Client a : Site b : 03/05/2016 : B 26	: Tank 123 : K0xx-16 : Jxx86
--	------------------------------------

Topside-Differential

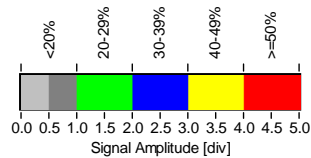
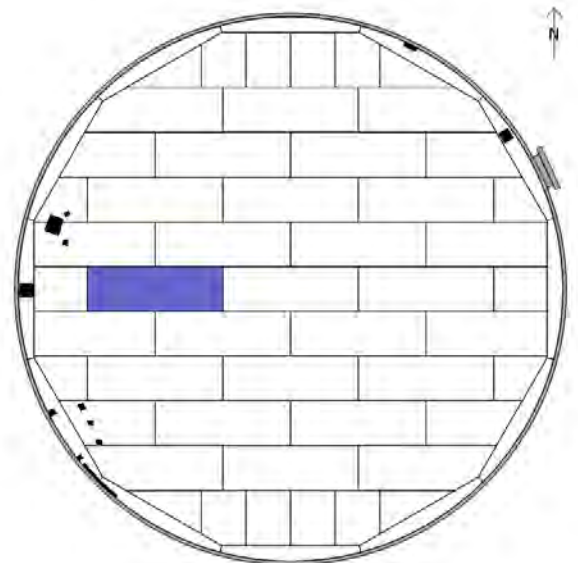
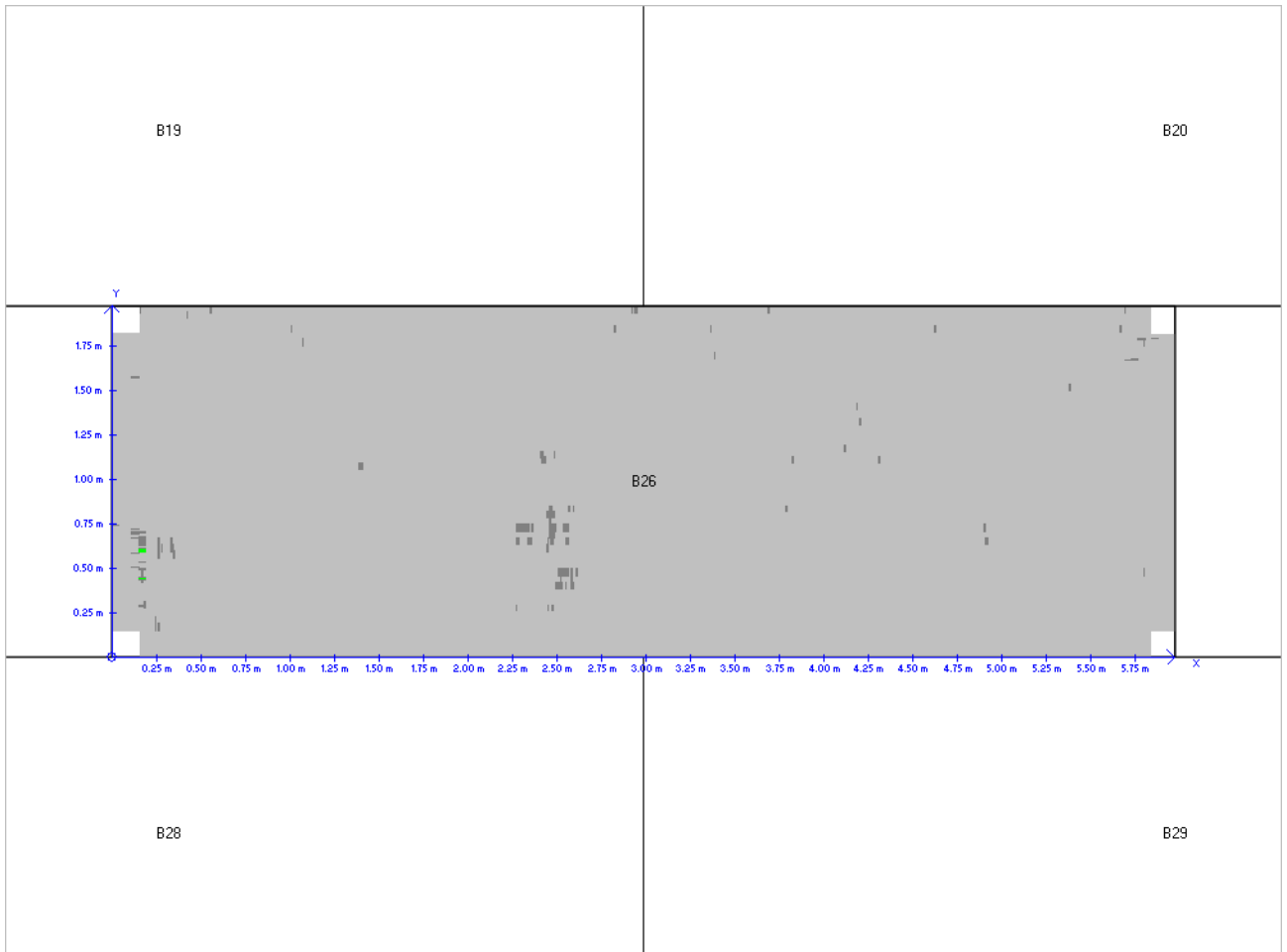

<ul style="list-style-type: none"> : Client a : Site b : 03/05/2016 : B 27 	<ul style="list-style-type: none"> : Tank 123 : K0xx-16 : Jxx86
--	--

Topside-Differential

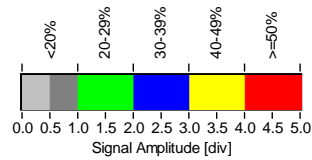
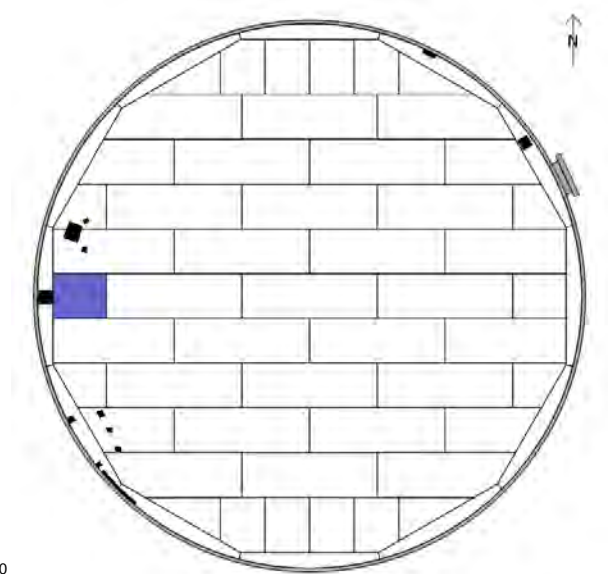
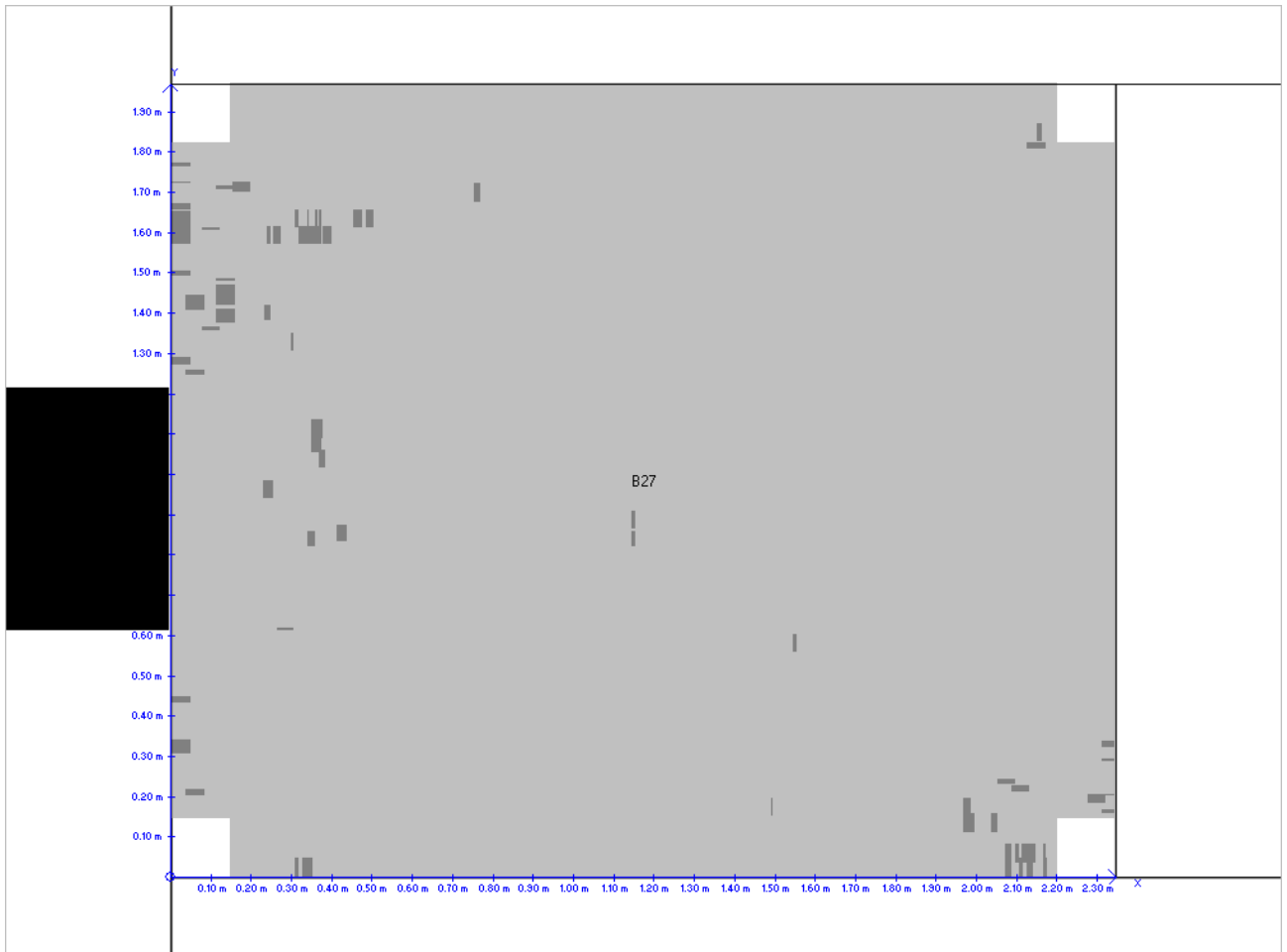

<ul style="list-style-type: none"> : Client a : Site b : 03/05/2016 : B 28 	<ul style="list-style-type: none"> : Tank 123 : K0xx-16 : Jxx86
--	--

Topside-Differential

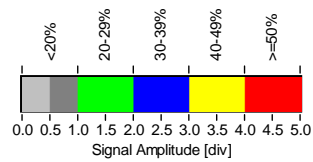
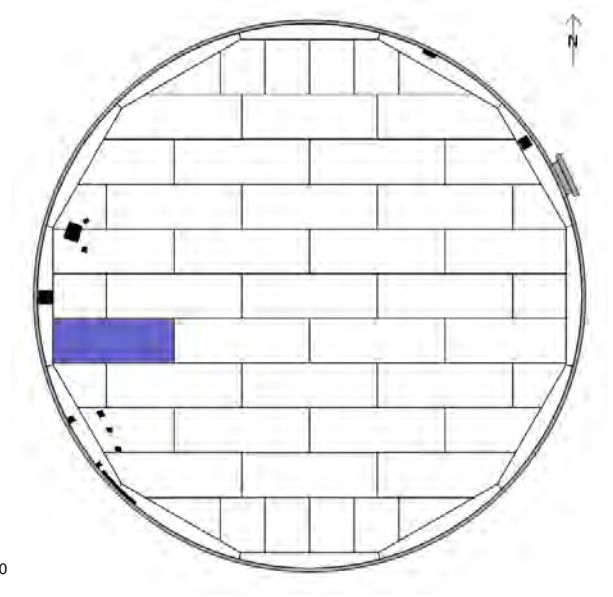
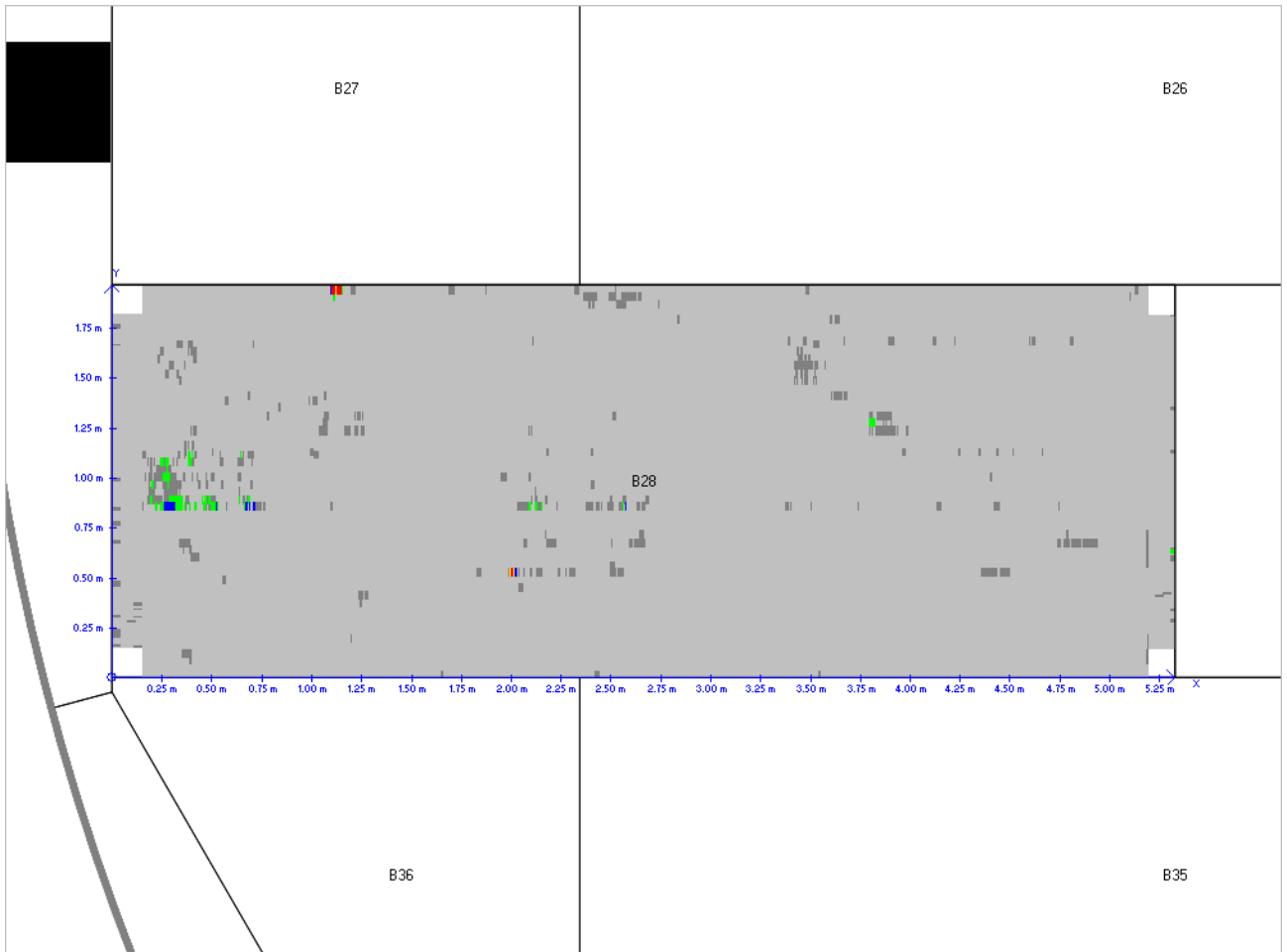

: Client a : Site b : 03/05/2016 : B 29	: Tank 123 : K0xx-16 : Jxx86
--	------------------------------------

Topside-Differential

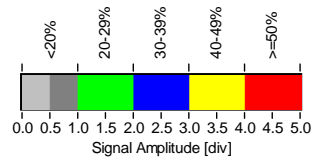
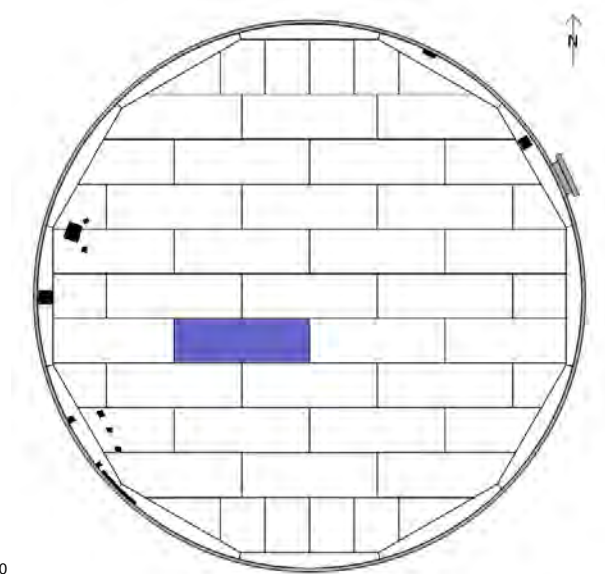
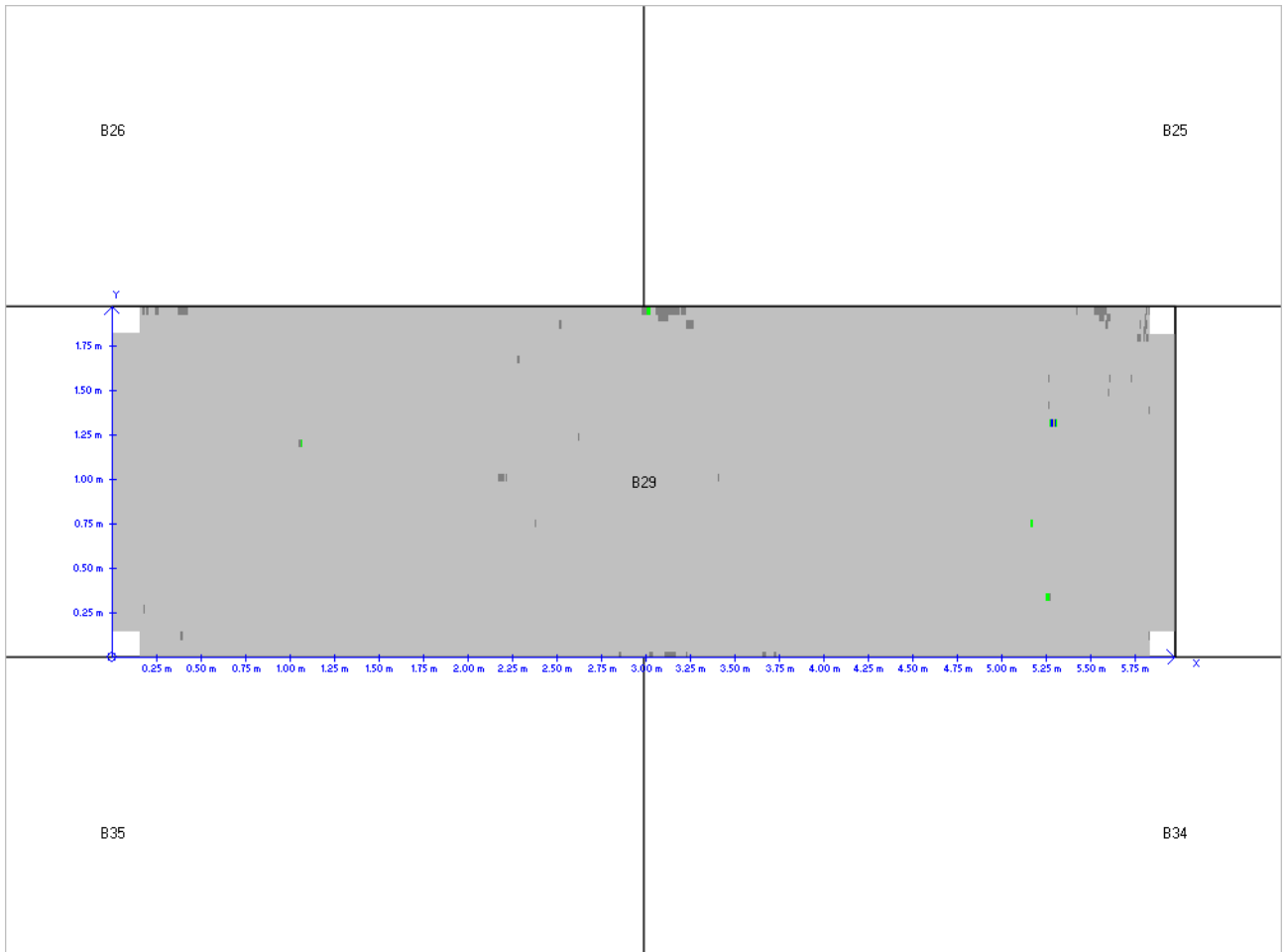

: Client a : Site b : 03/05/2016 : B 30	: Tank 123 : K0xx-16 : Jxx86
--	------------------------------------

Topside-Differential

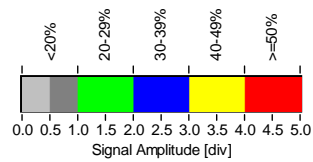
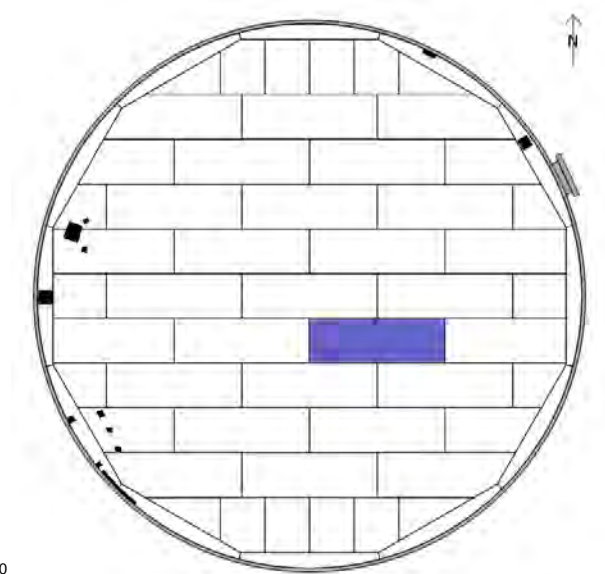
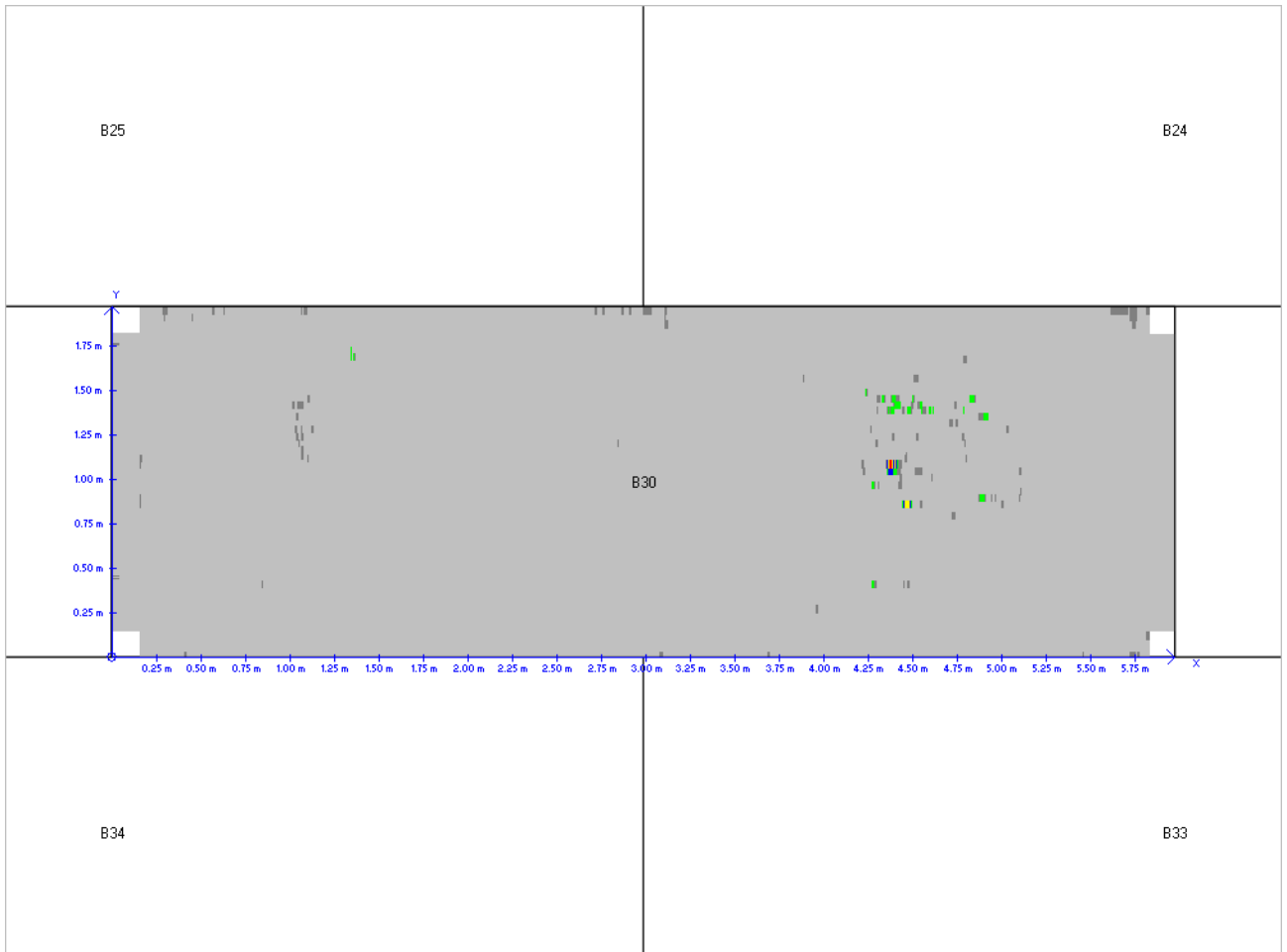

<ul style="list-style-type: none"> : Client a : Site b : 03/05/2016 : B 31 	<ul style="list-style-type: none"> : Tank 123 : K0xx-16 : Jxx86
--	--

Topside-Differential

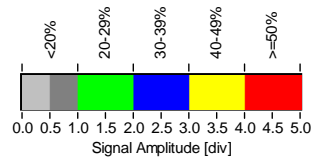
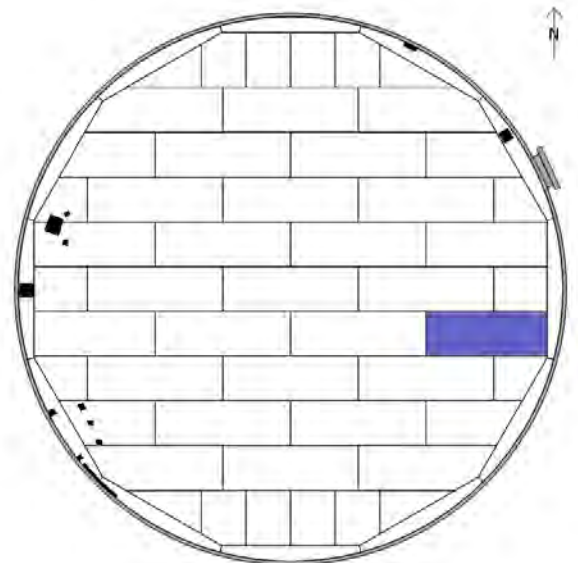
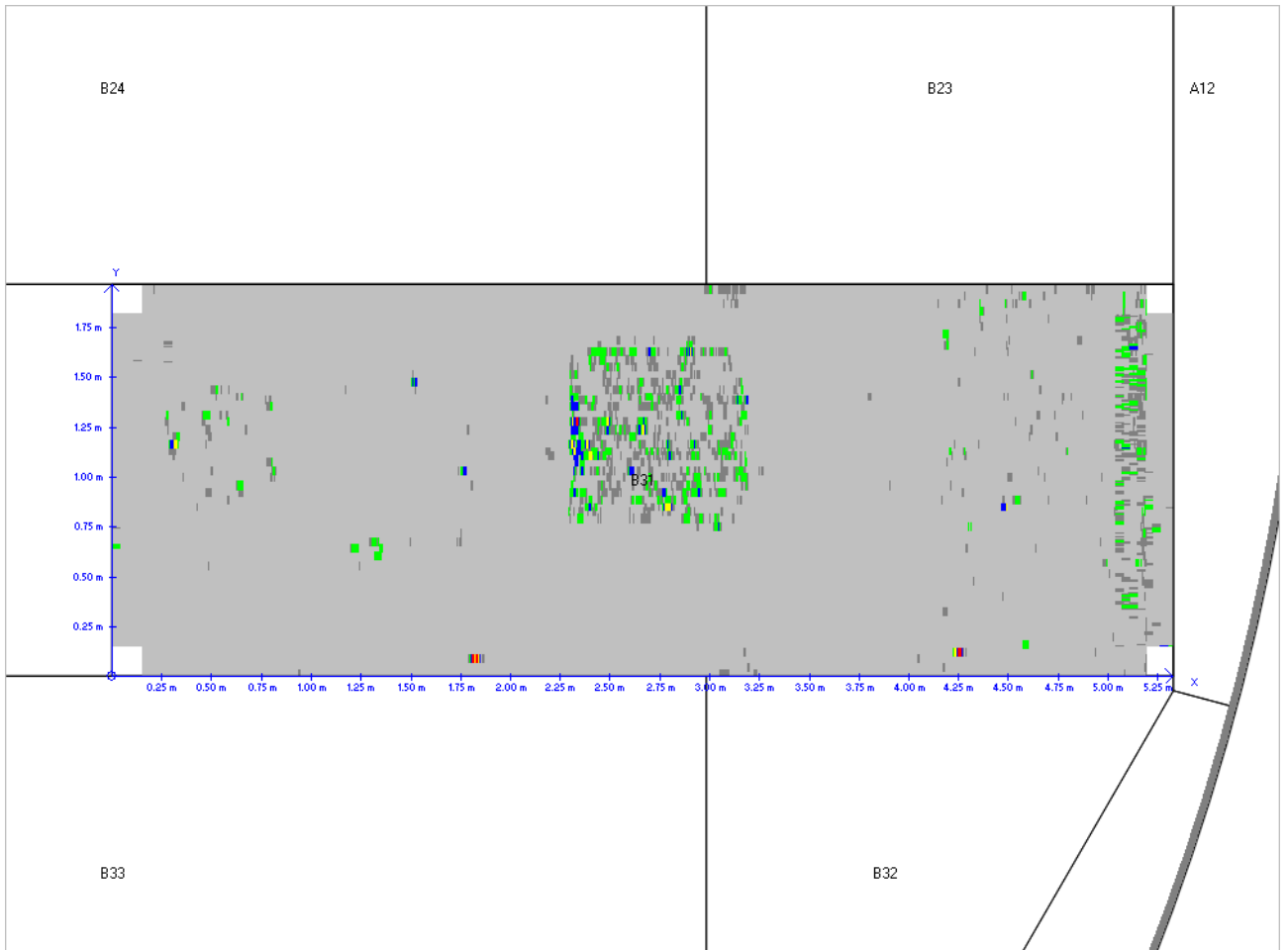

<ul style="list-style-type: none"> : Client a : Site b : 03/05/2016 : B 32 	<ul style="list-style-type: none"> : Tank 123 : K0xx-16 : Jxx86
--	--

Topside-Differential

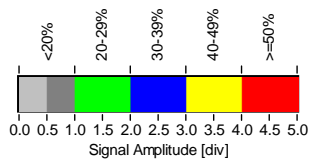
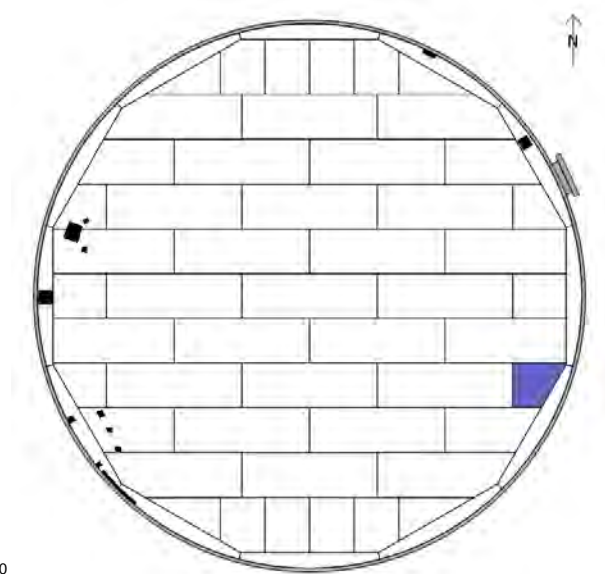
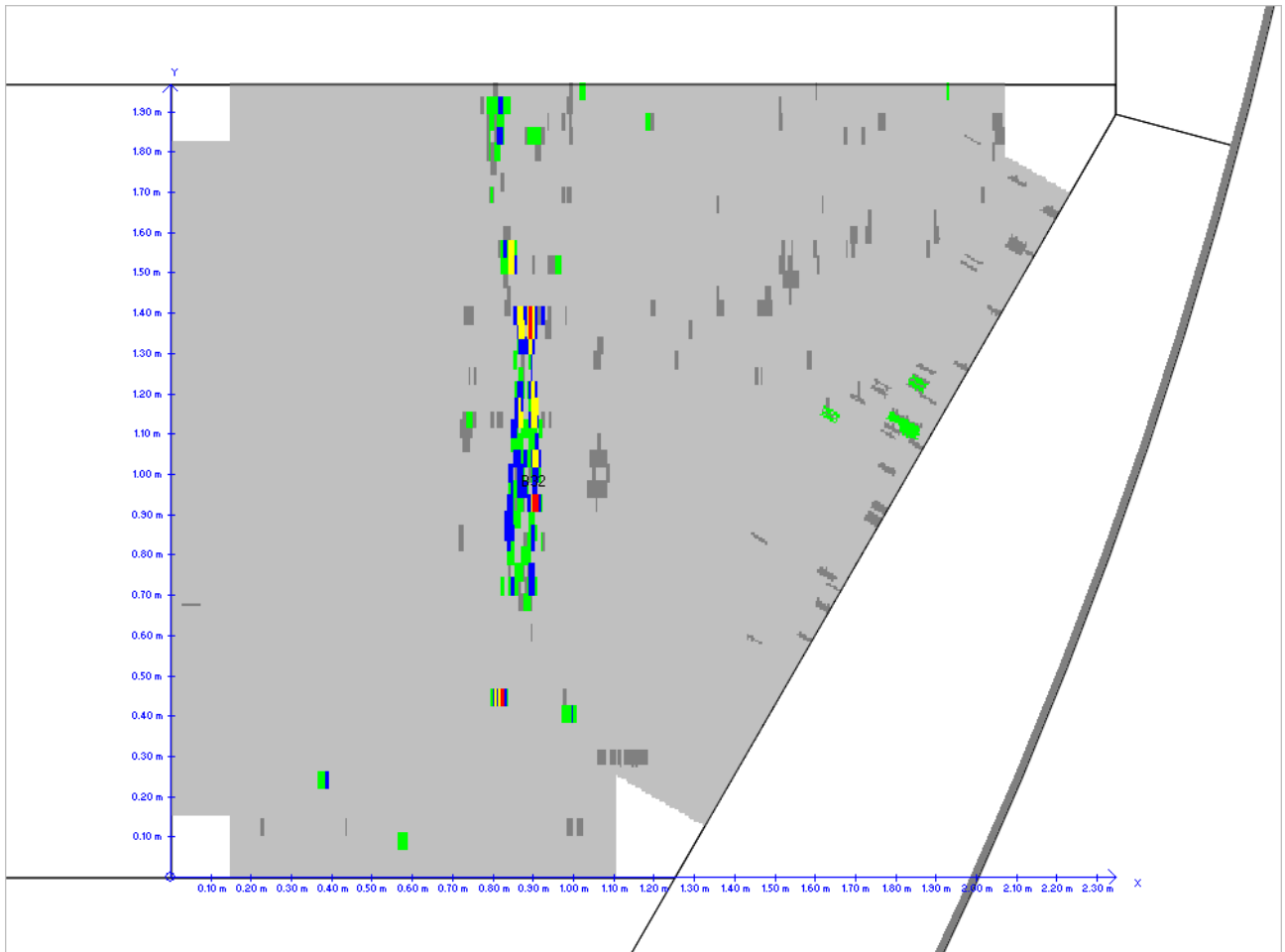

<ul style="list-style-type: none"> : Client a : Site b : 03/05/2016 : B 33 	<ul style="list-style-type: none"> : Tank 123 : K0xx-16 : Jxx86
--	--

Topside-Differential

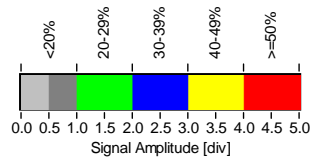
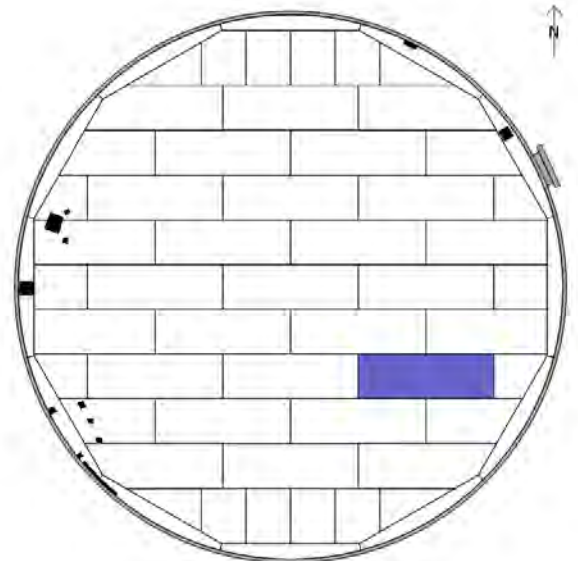
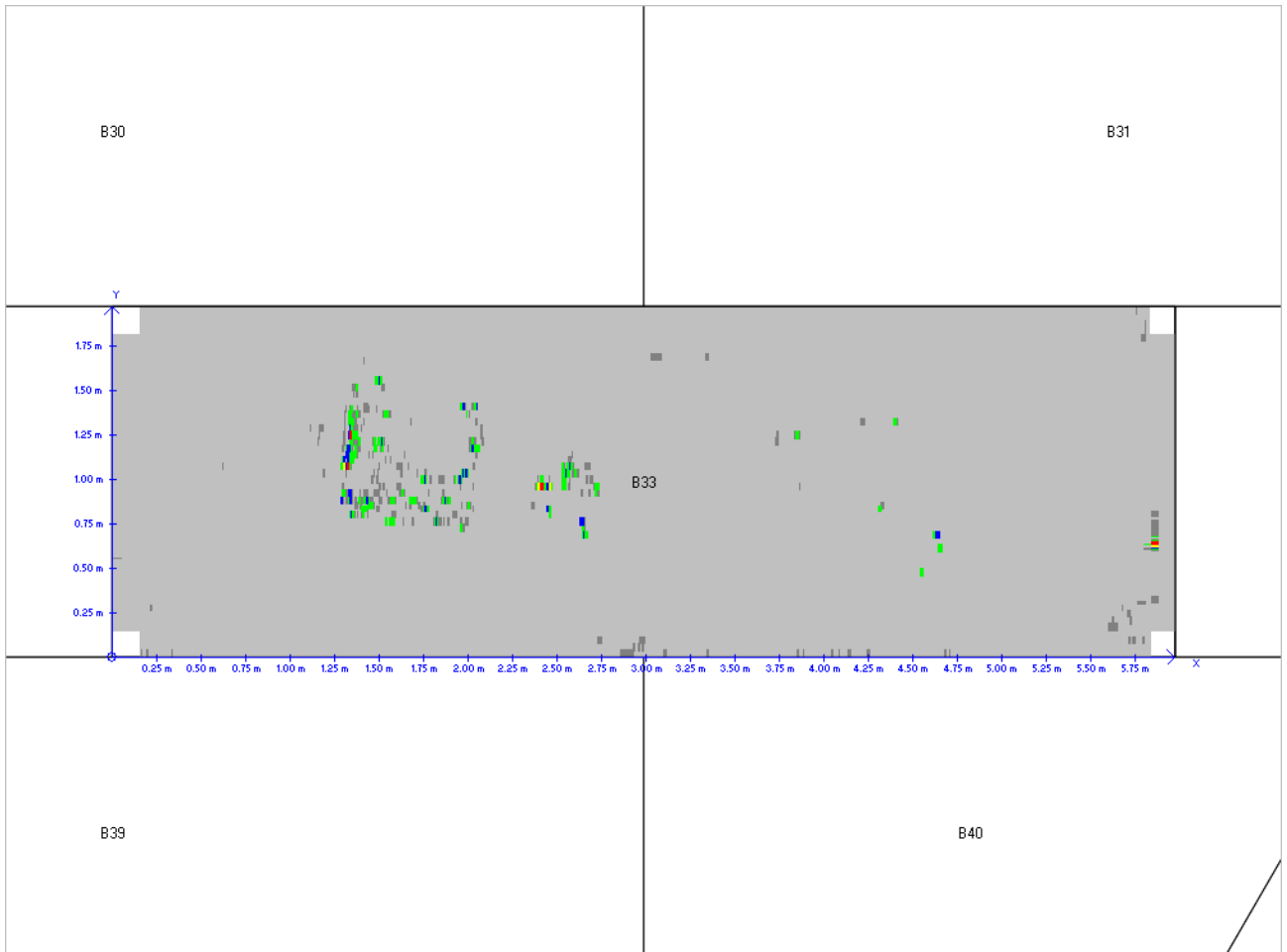

: Client a : Site b : 03/05/2016 : B 34	: Tank 123 : K0xx-16 : Jxx86
--	------------------------------------

Topside-Differential

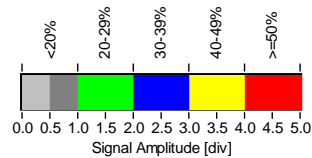
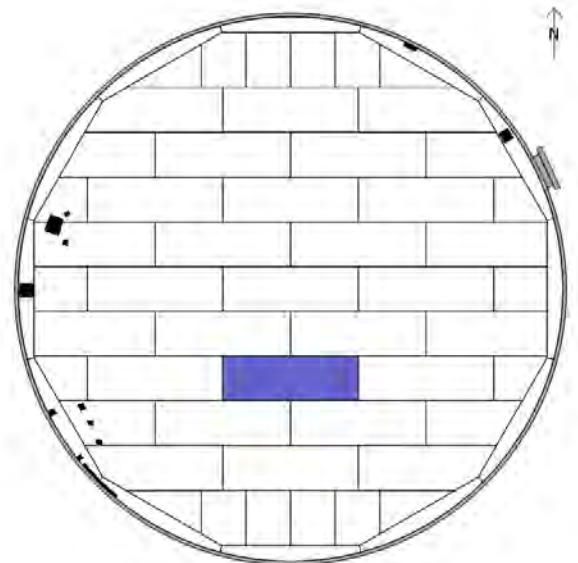
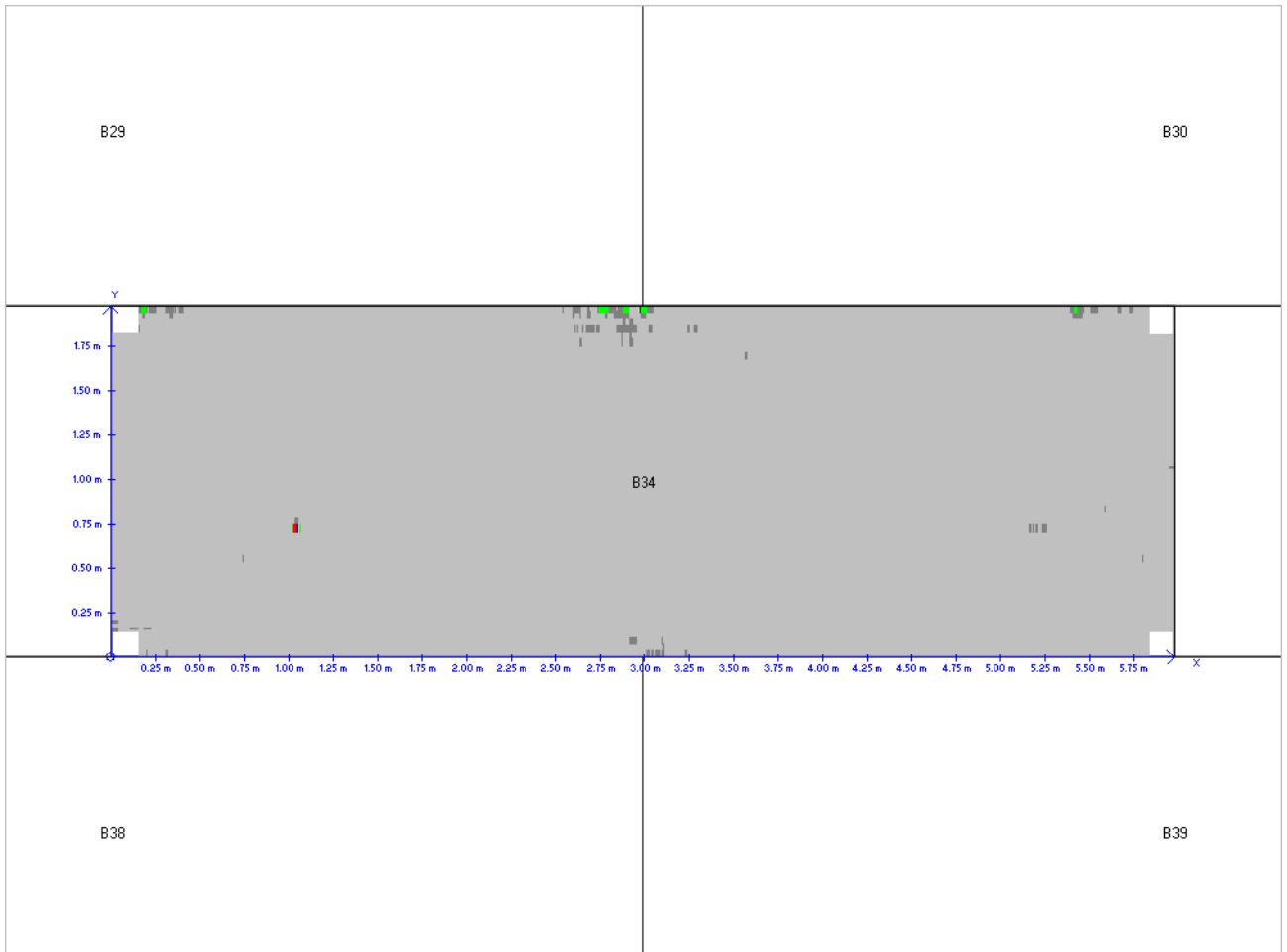

: Client a : Site b : 03/05/2016 : B 35	: Tank 123 : K0xx-16 : Jxx86
--	------------------------------------

Topside-Differential

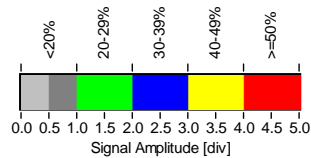
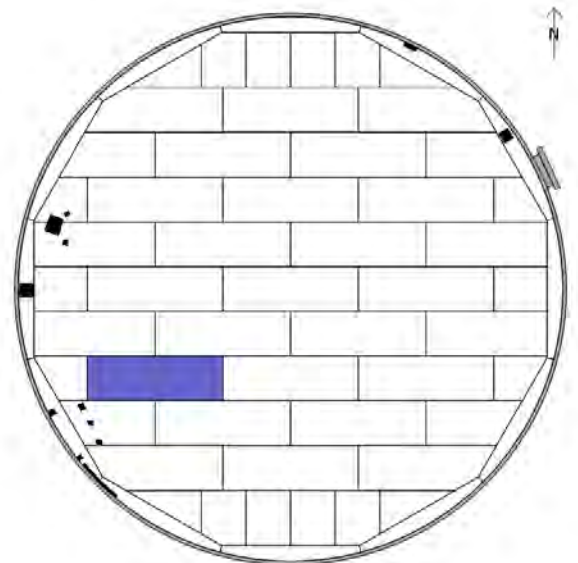
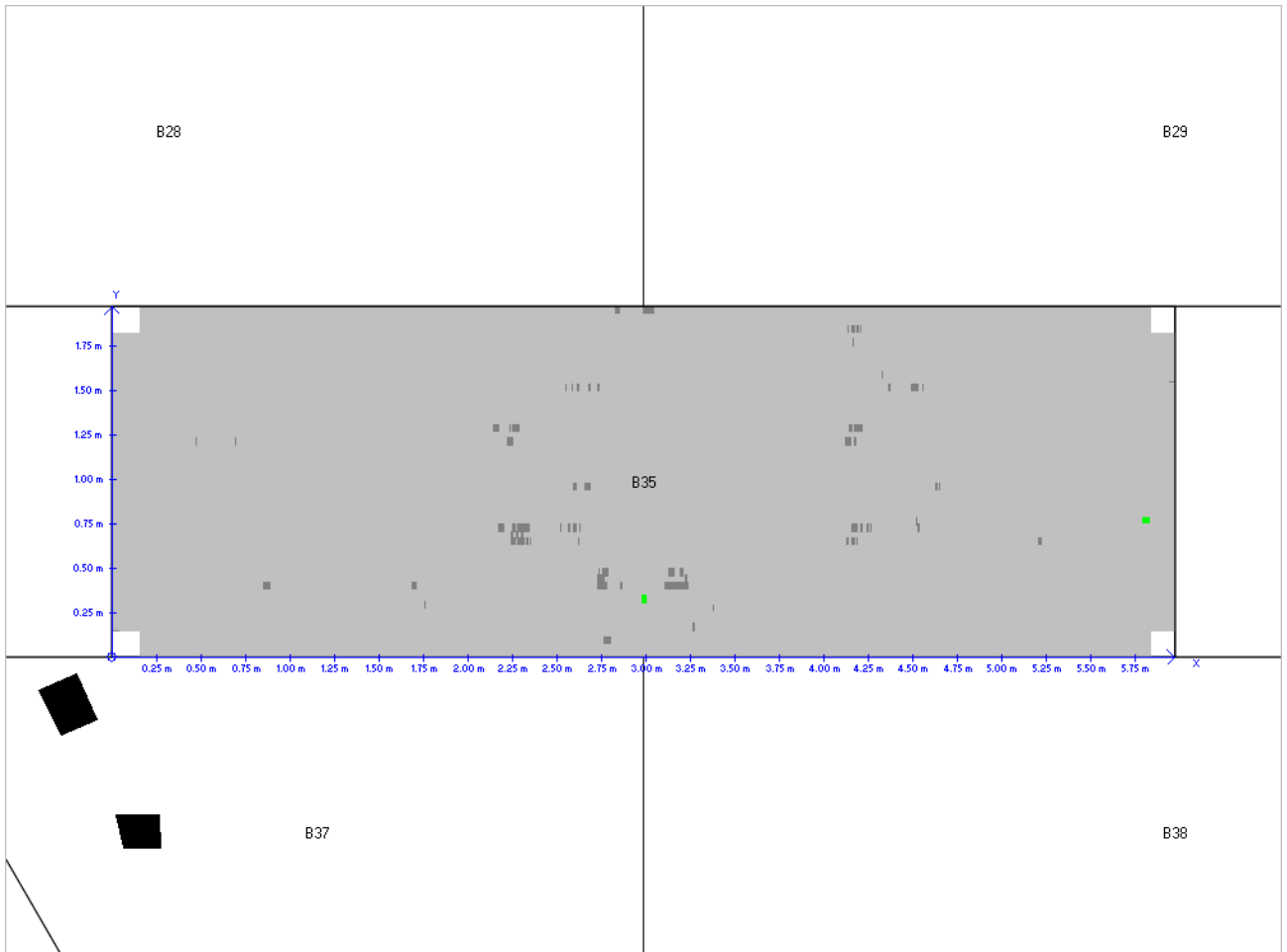

<ul style="list-style-type: none"> : Client a : Site b : 03/05/2016 : B 36 	<ul style="list-style-type: none"> : Tank 123 : K0xx-16 : Jxx86
--	--

Topside-Differential

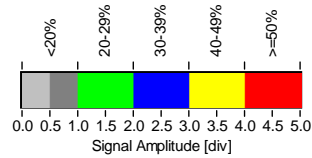
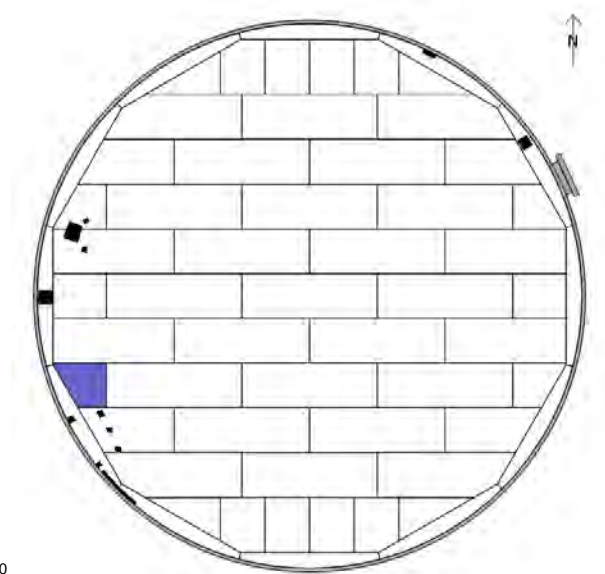
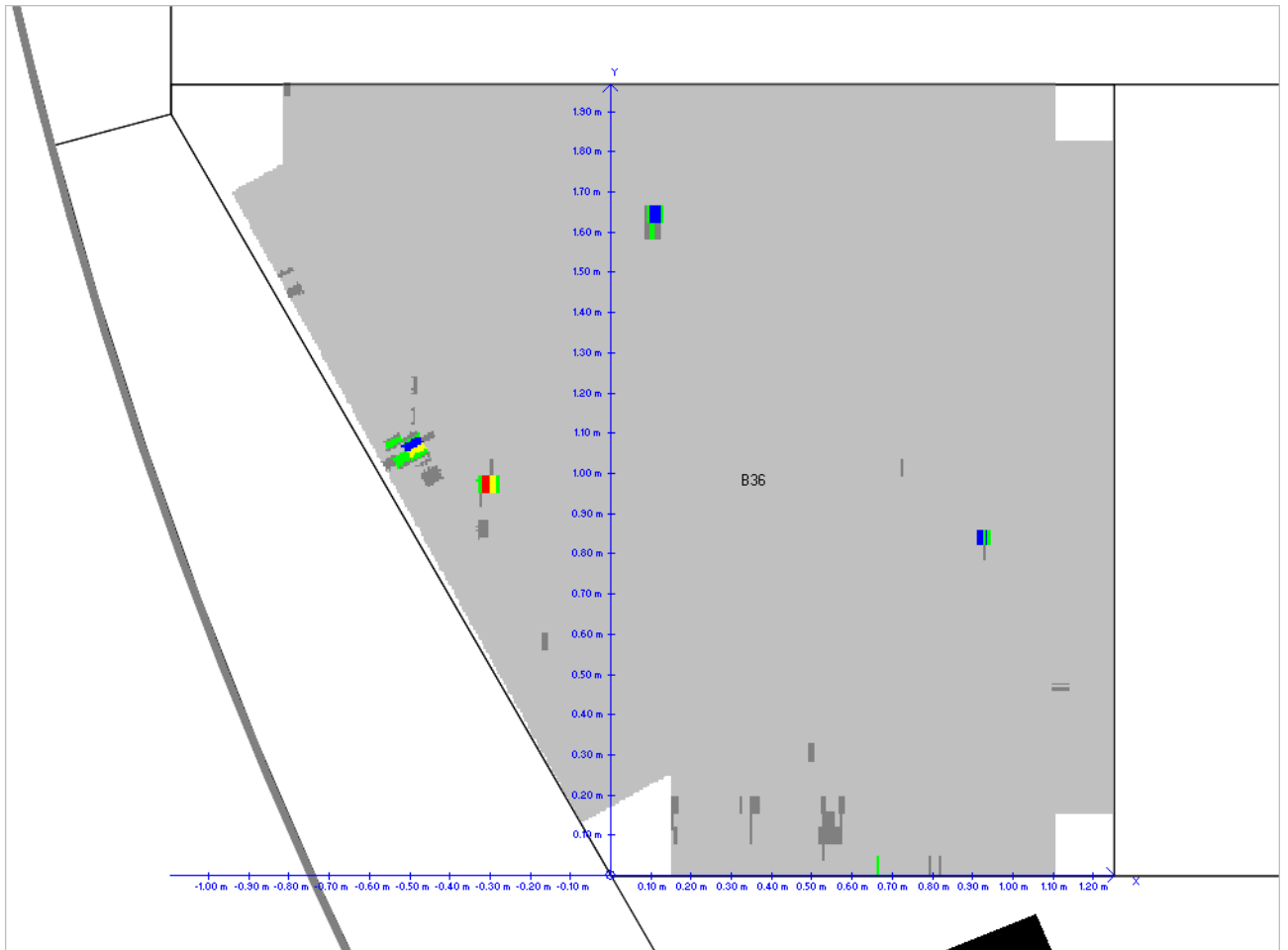

: Client a : Site b : 03/05/2016 : B 37	: Tank 123 : K0xx-16 : Jxx86
--	------------------------------------

Topside-Differential

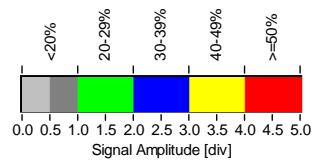
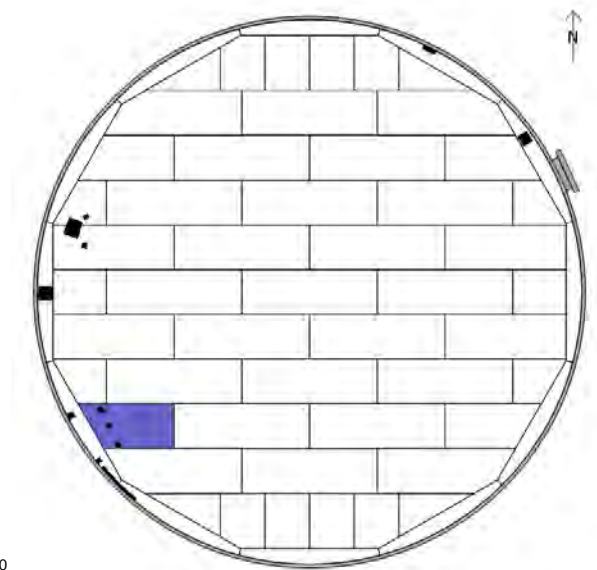
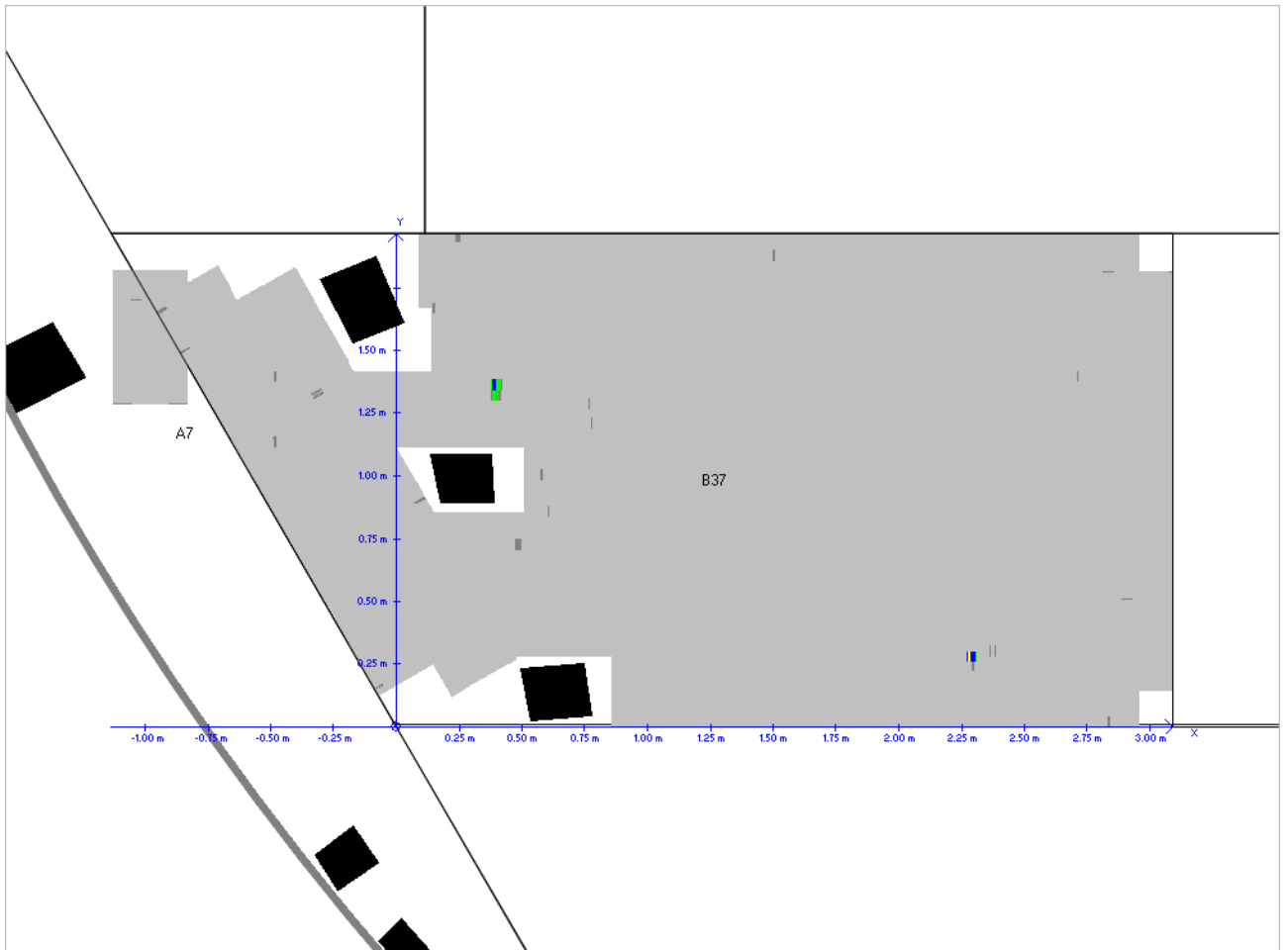

: Client a : Site b : 03/05/2016 : B 38	: Tank 123 : K0xx-16 : Jxx86
--	------------------------------------

Topside-Differential

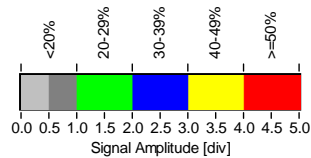
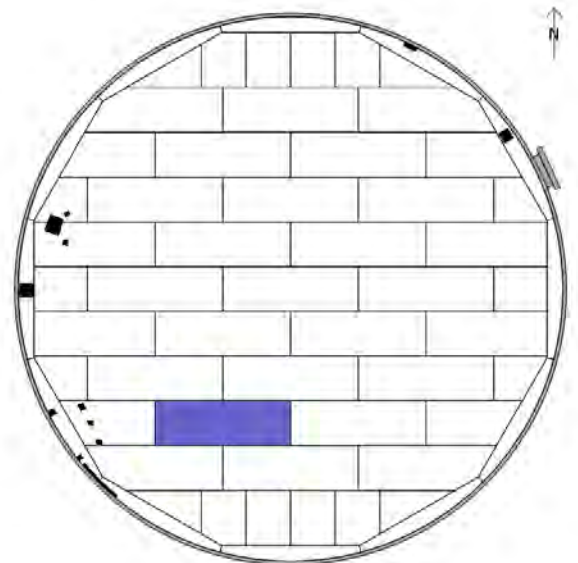
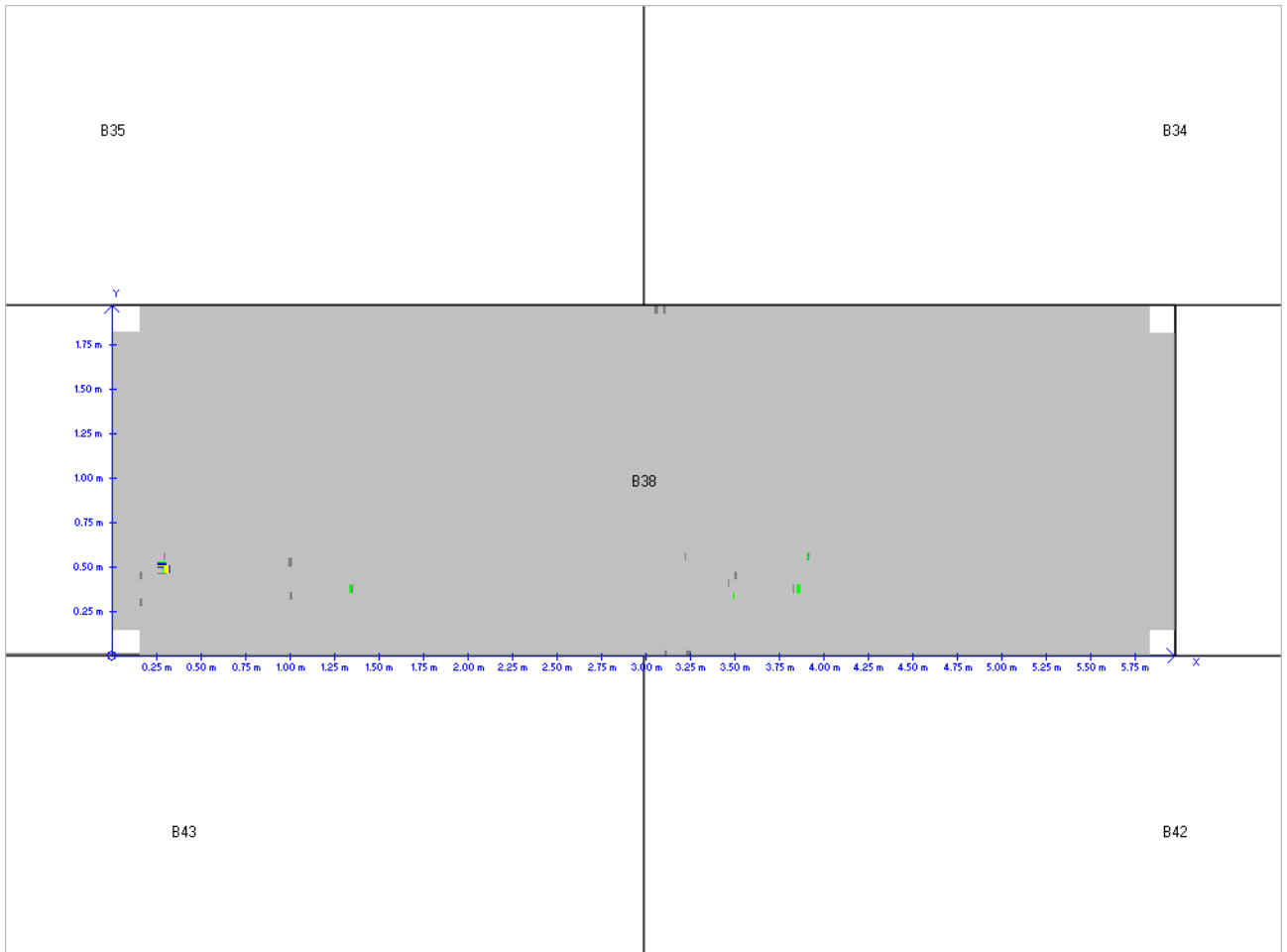

: Client a : Site b : 03/05/2016 : B 39	: Tank 123 : K0xx-16 : Jxx86
--	------------------------------------

Topside-Differential

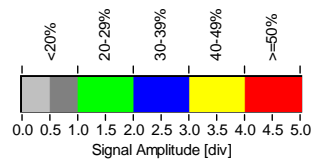
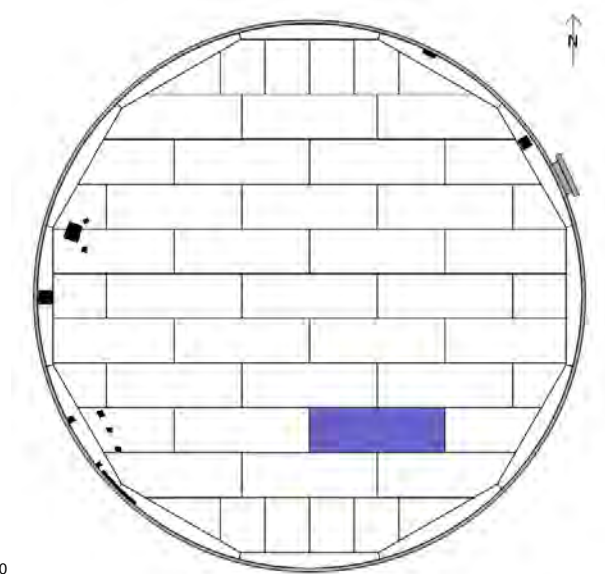
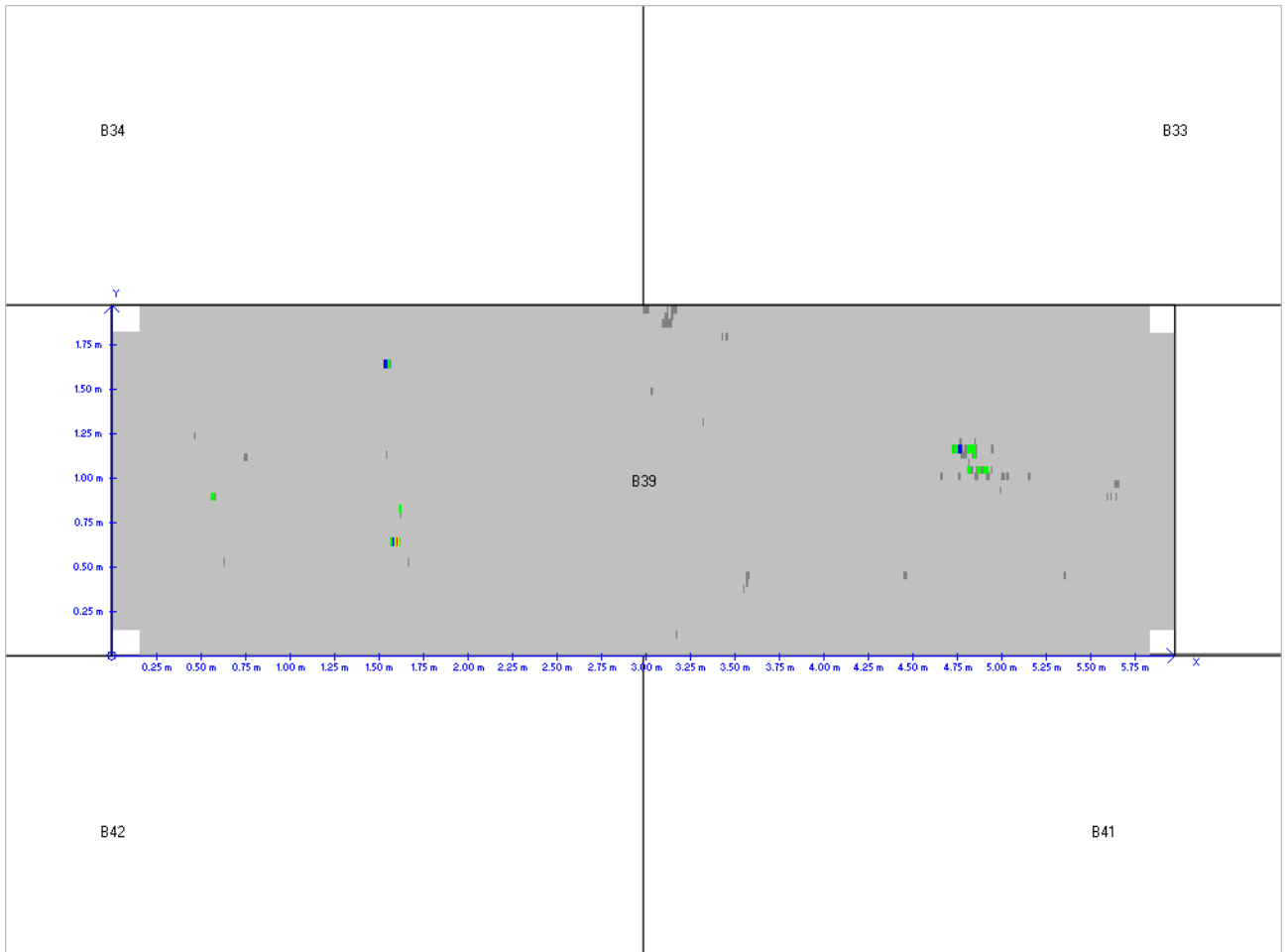

<ul style="list-style-type: none"> : Client a : Site b : 03/05/2016 : B 40 	<ul style="list-style-type: none"> : Tank 123 : K0xx-16 : Jxx86
--	--

Topside-Differential

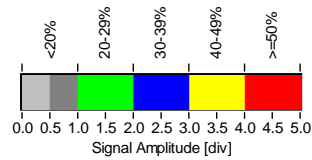
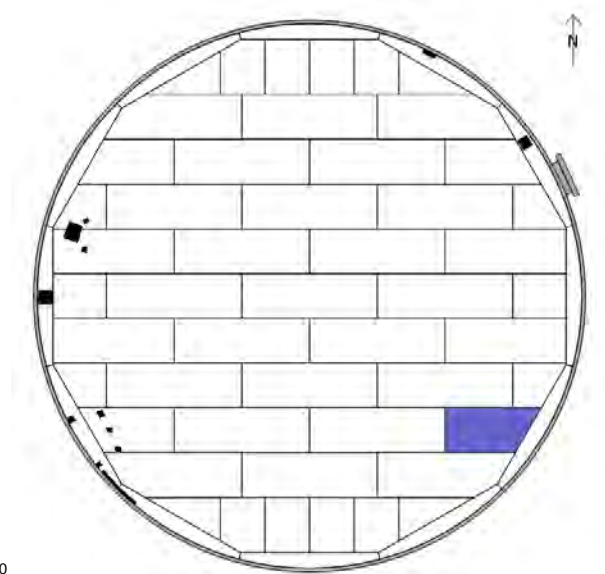
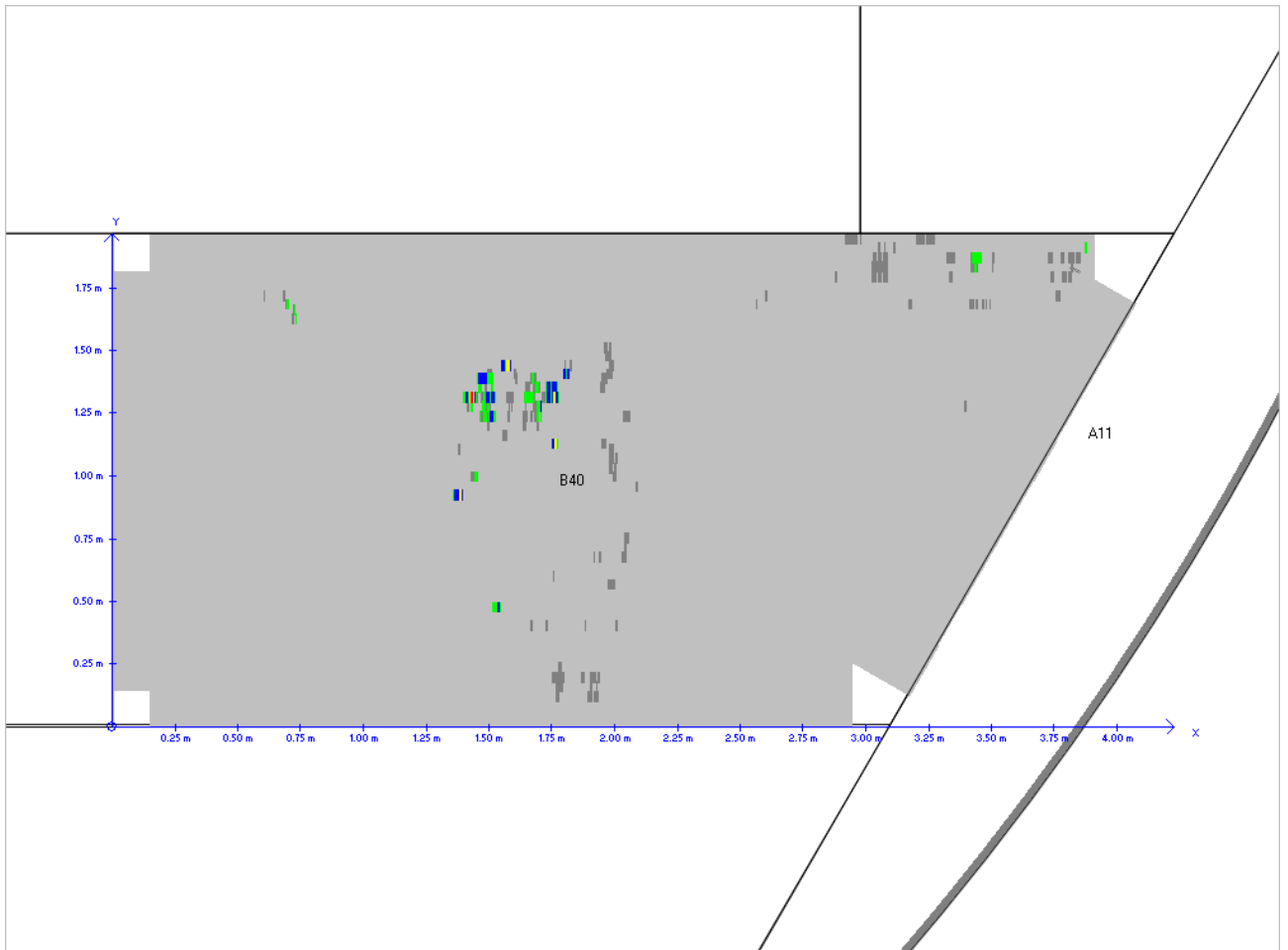

: Client a : Site b : 03/05/2016 : B 41	: Tank 123 : K0xx-16 : Jxx86
--	------------------------------------

Topside-Differential

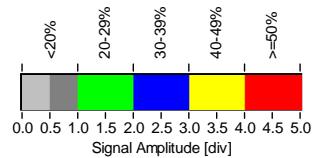
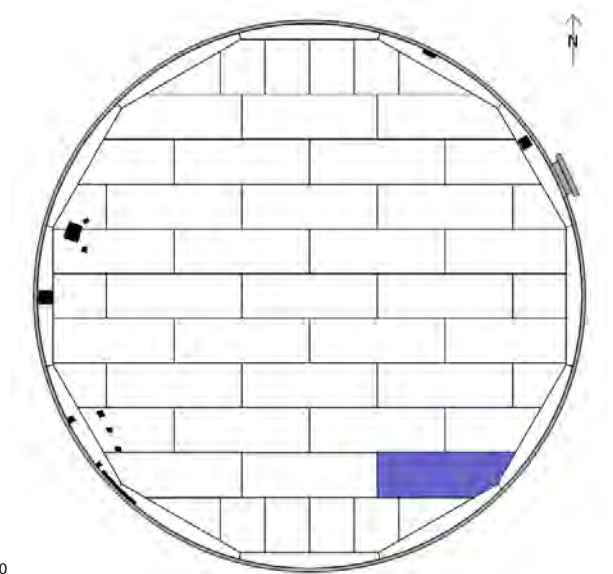
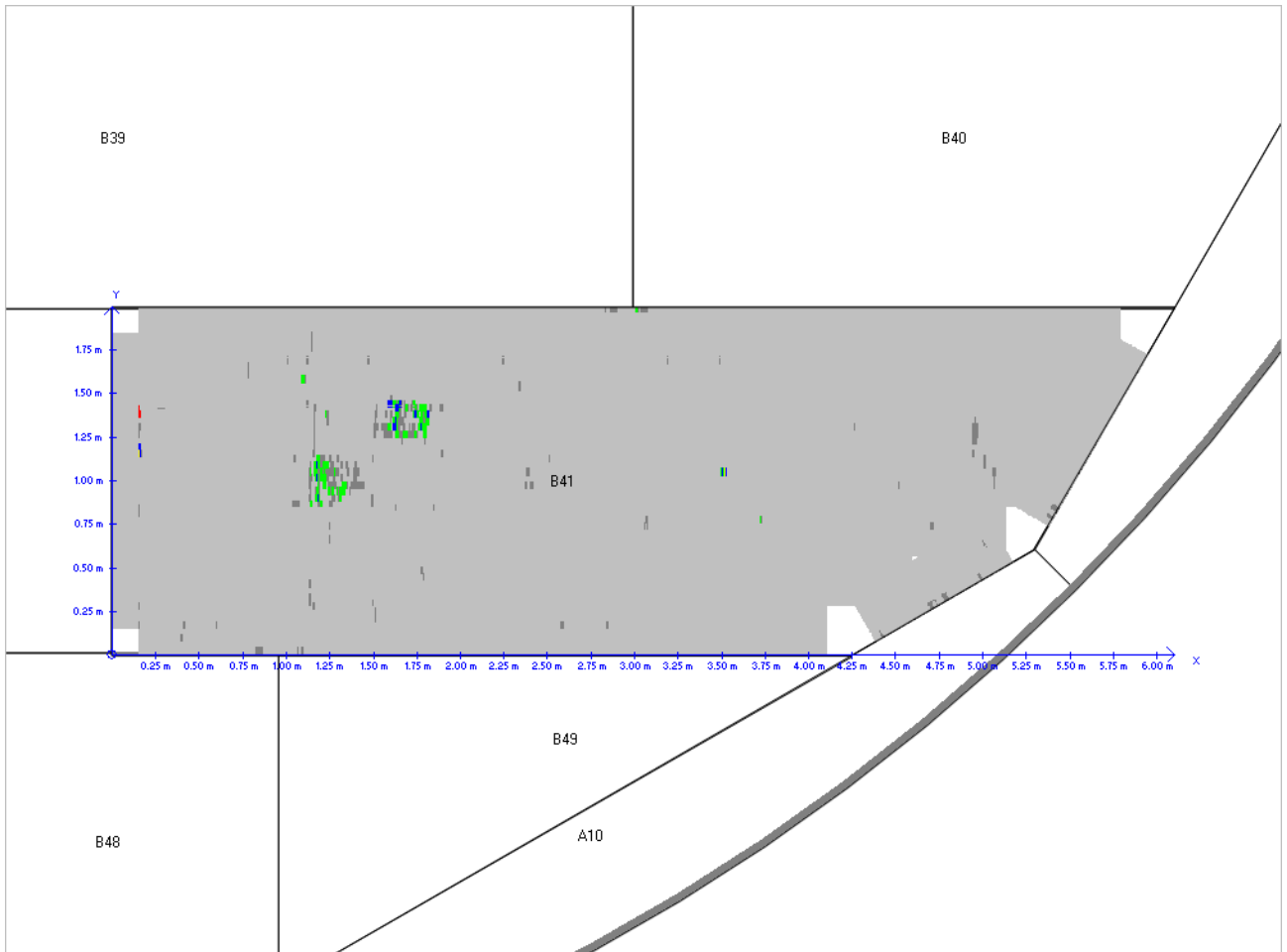

: Client a : Site b : 03/05/2016 : B 42	: Tank 123 : K0xx-16 : Jxx86
--	------------------------------------

Topside-Differential

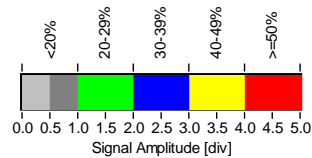
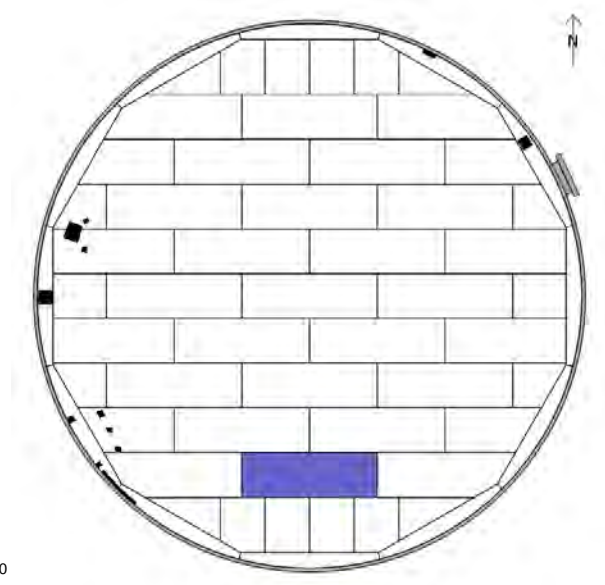
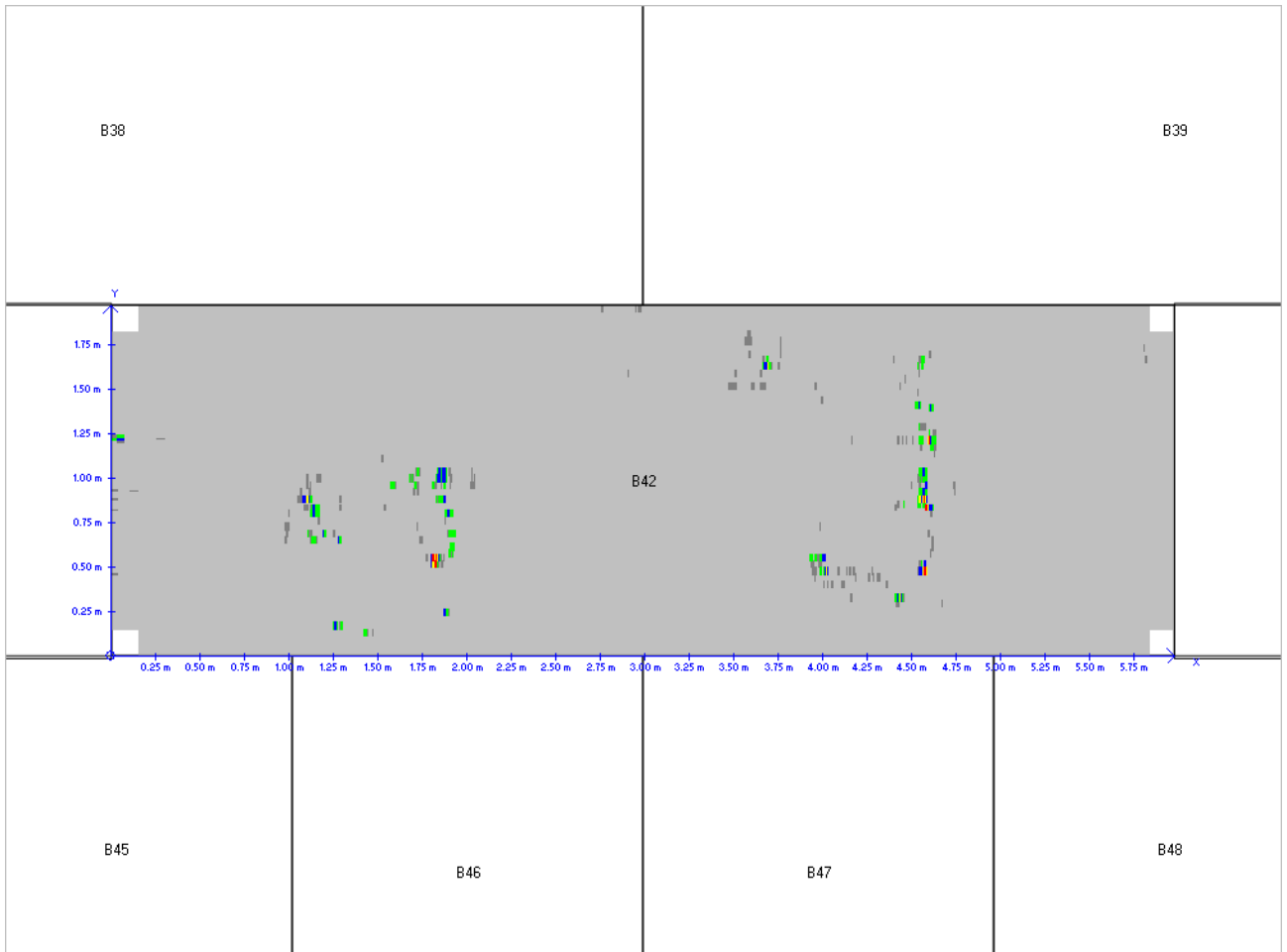

<ul style="list-style-type: none"> : Client a : Site b : 03/05/2016 : B 43 	<ul style="list-style-type: none"> : Tank 123 : K0xx-16 : Jxx86
--	--

Topside-Differential

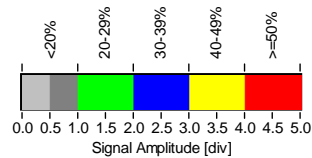
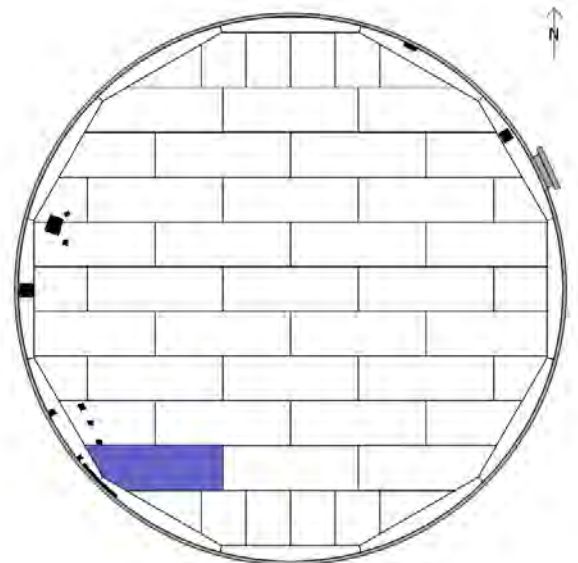
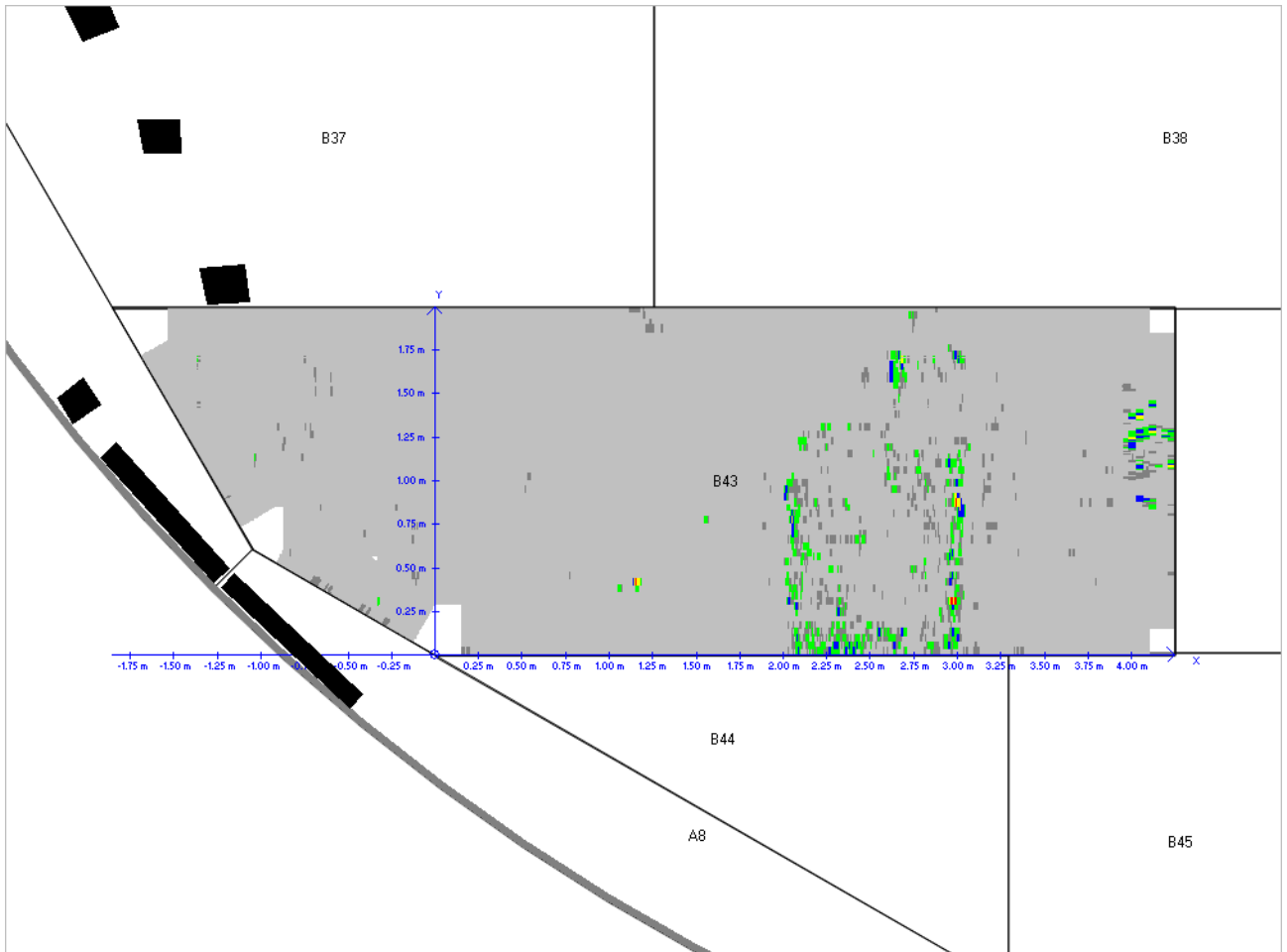

<ul style="list-style-type: none"> : Client a : Site b : 03/05/2016 : B 44 	<ul style="list-style-type: none"> : Tank 123 : K0xx-16 : Jxx86
--	--

Topside-Differential

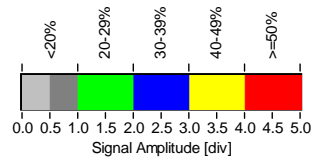
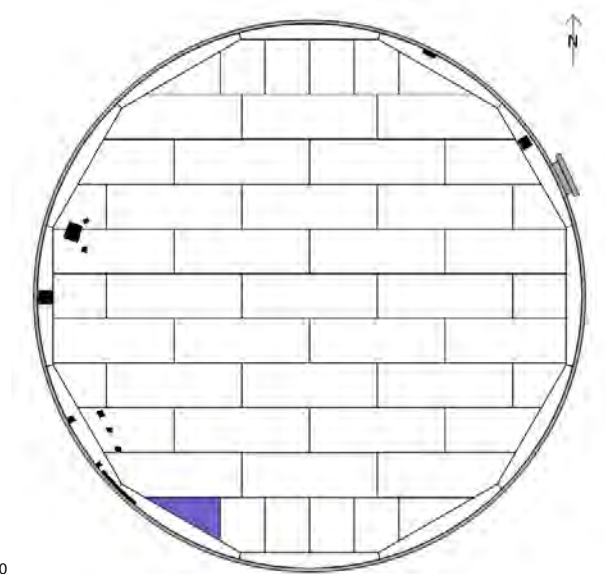
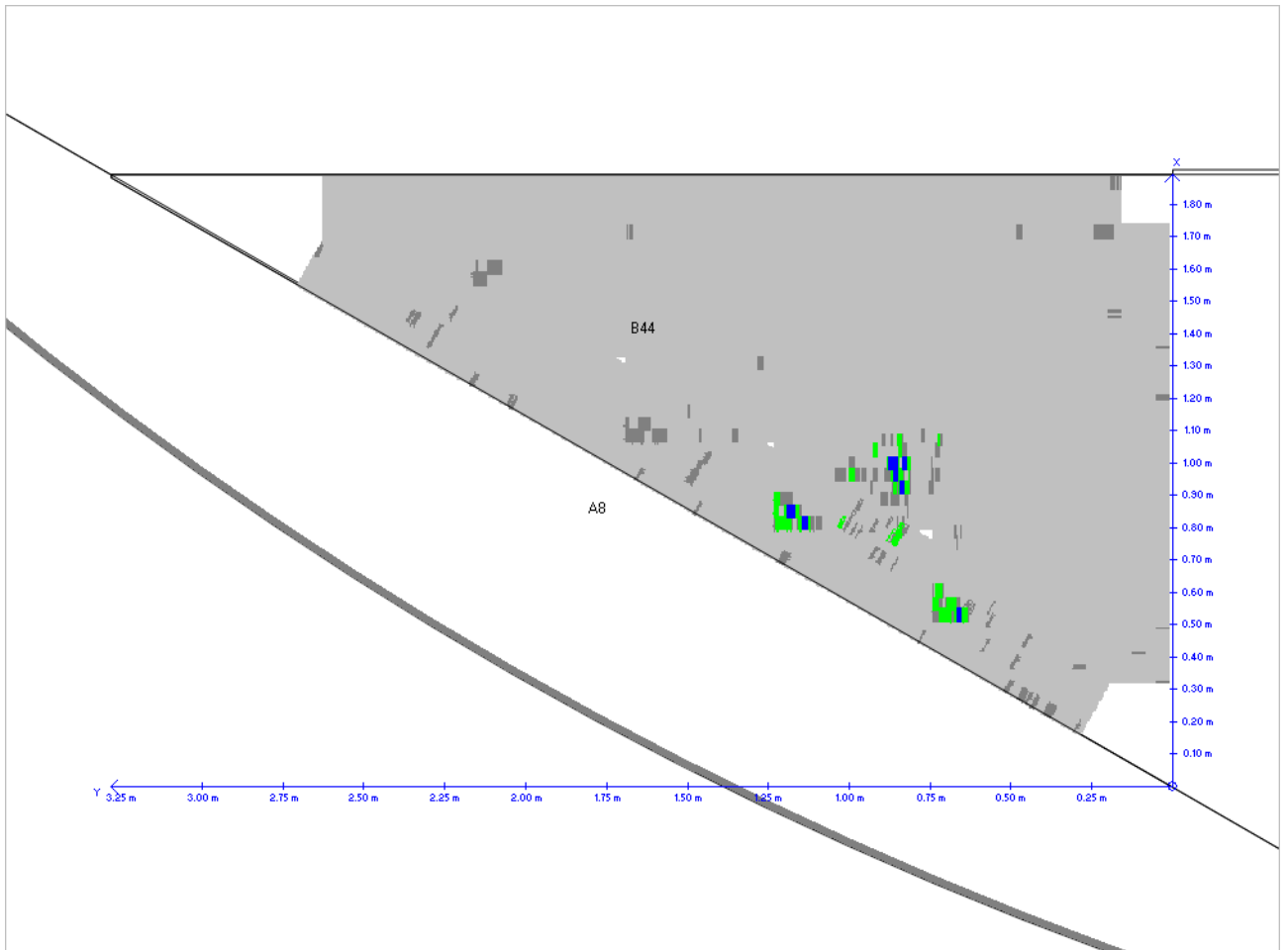

<ul style="list-style-type: none"> : Client a : Site b : 03/05/2016 : B 45 	<ul style="list-style-type: none"> : Tank 123 : K0xx-16 : Jxx86
--	--

Topside-Differential

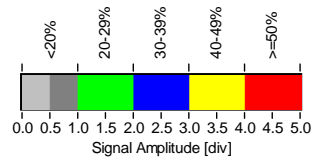
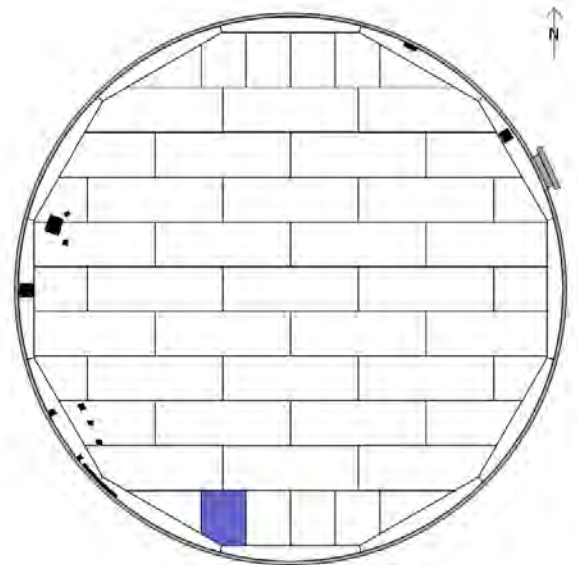
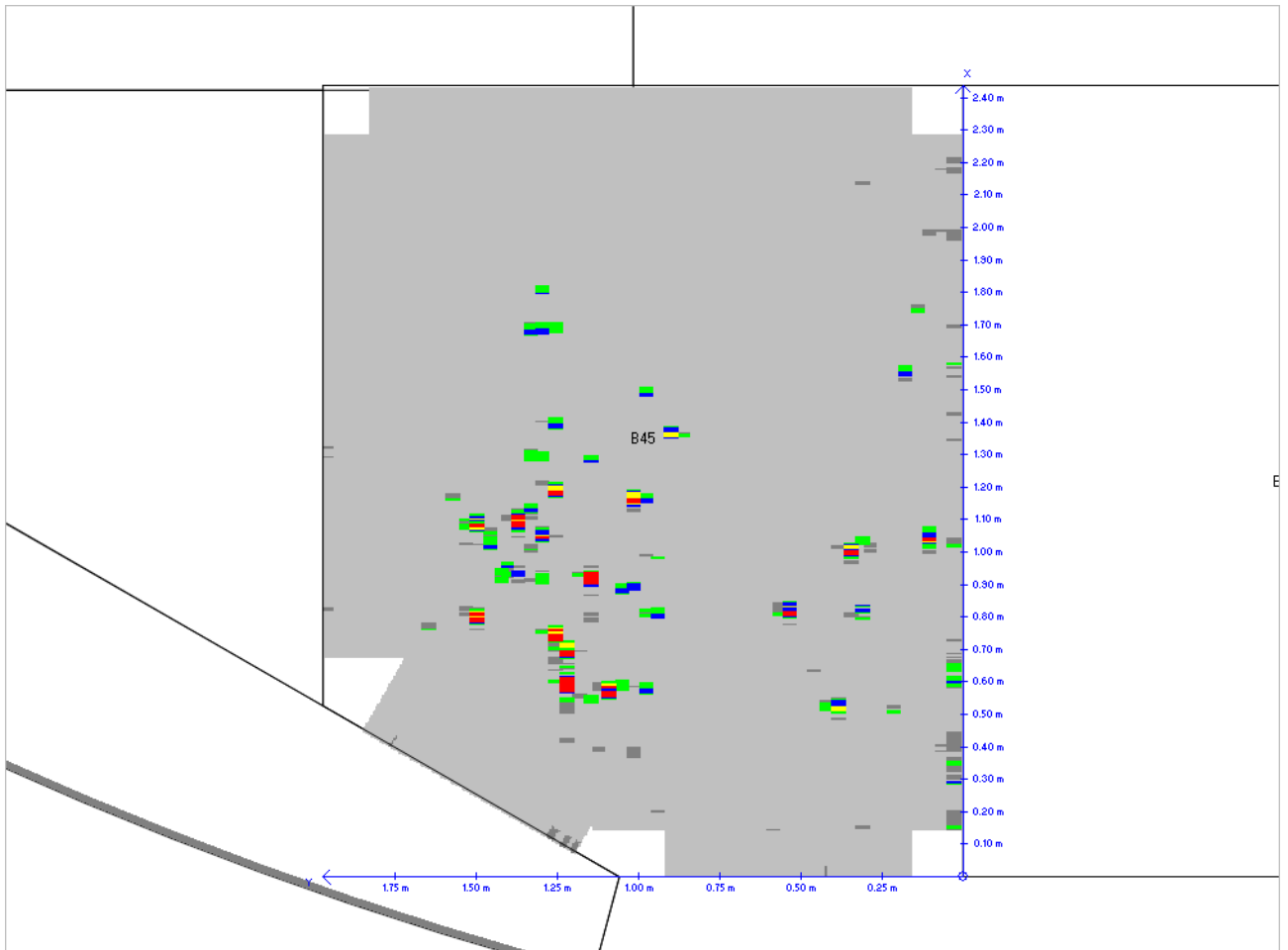

<ul style="list-style-type: none"> : Client a : Site b : 03/05/2016 : B 46 	<ul style="list-style-type: none"> : Tank 123 : K0xx-16 : Jxx86
--	--

Topside-Differential

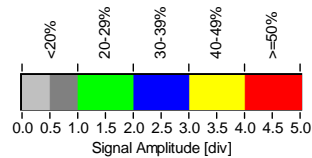
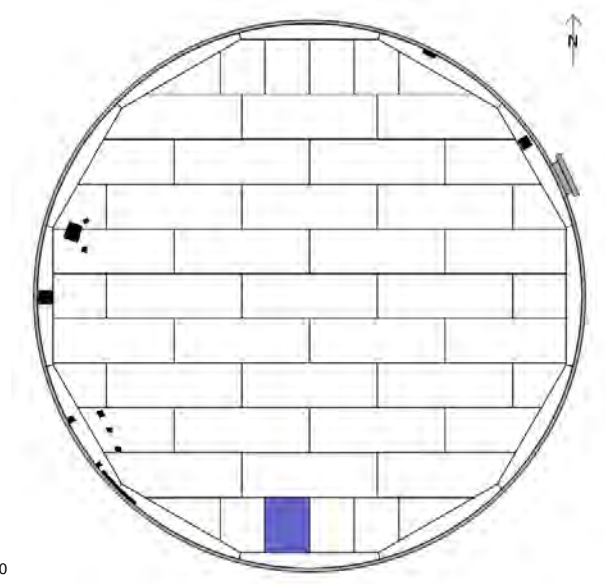
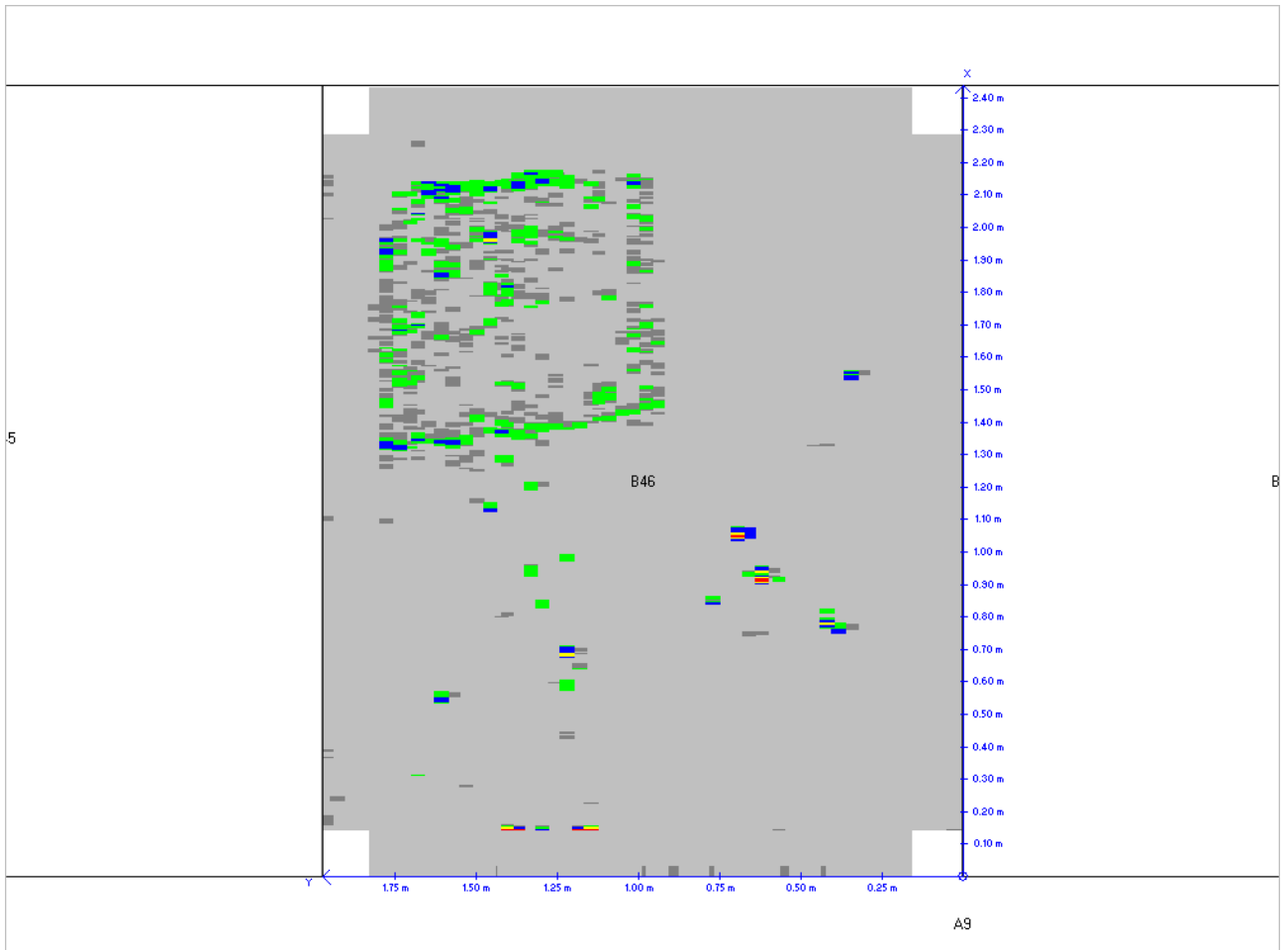

: Client a : Site b : 03/05/2016 : B 47	: Tank 123 : K0xx-16 : Jxx86
--	------------------------------------

Topside-Differential

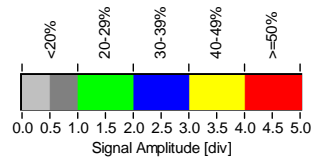
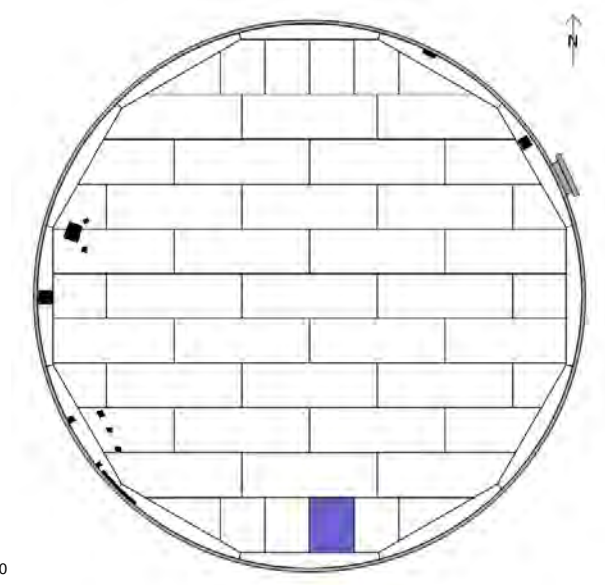
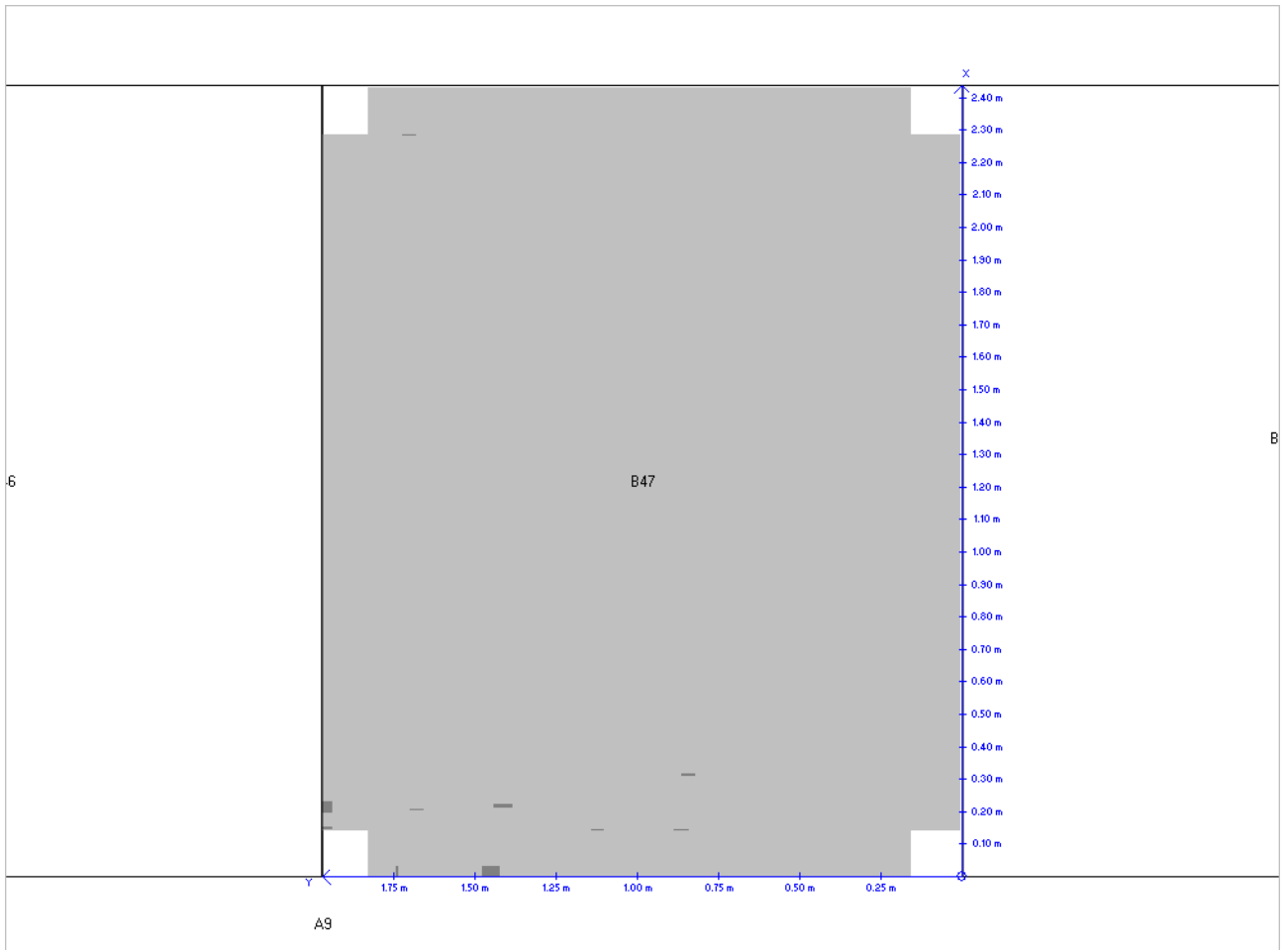

<ul style="list-style-type: none"> : Client a : Site b : 03/05/2016 : B 48 	<ul style="list-style-type: none"> : Tank 123 : K0xx-16 : Jxx86
--	--

Topside-Differential

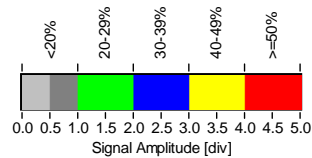
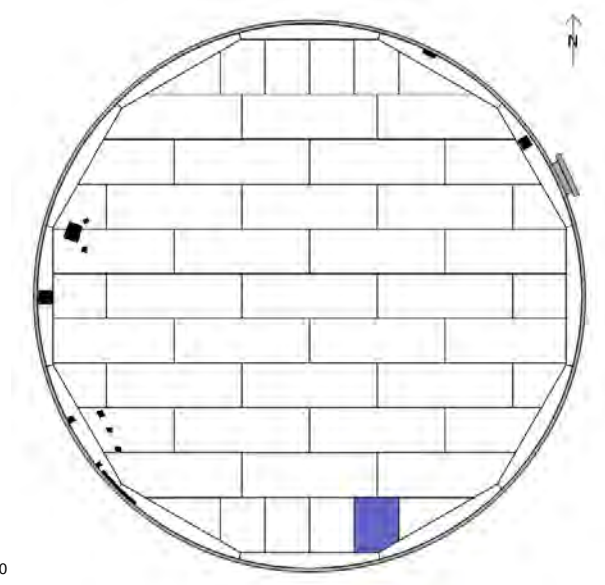
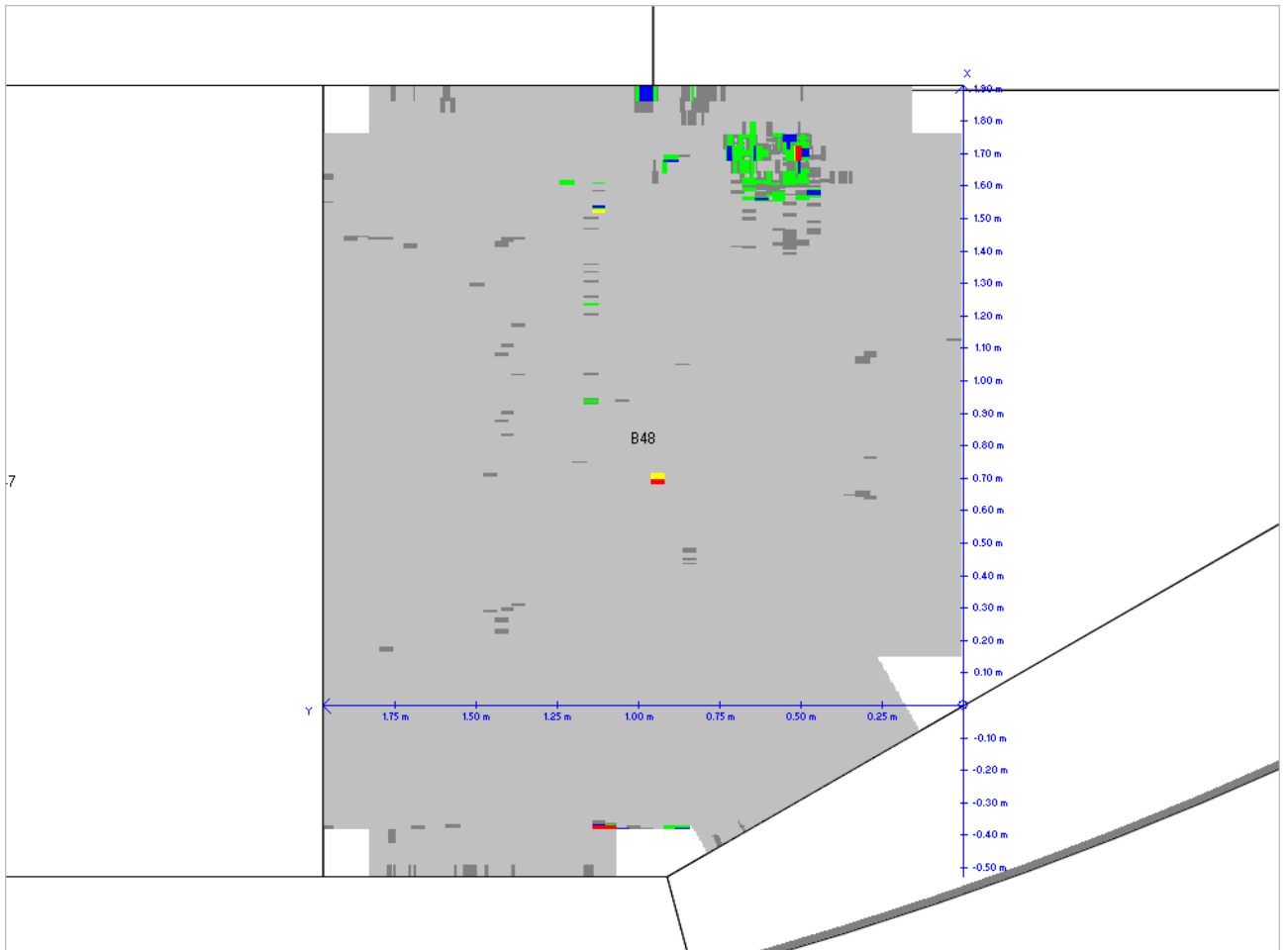

<ul style="list-style-type: none"> : Client a : Site b : 03/05/2016 : B 49 	<ul style="list-style-type: none"> : Tank 123 : K0xx-16 : Jxx86
--	--

Topside-Differential

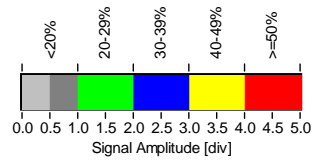
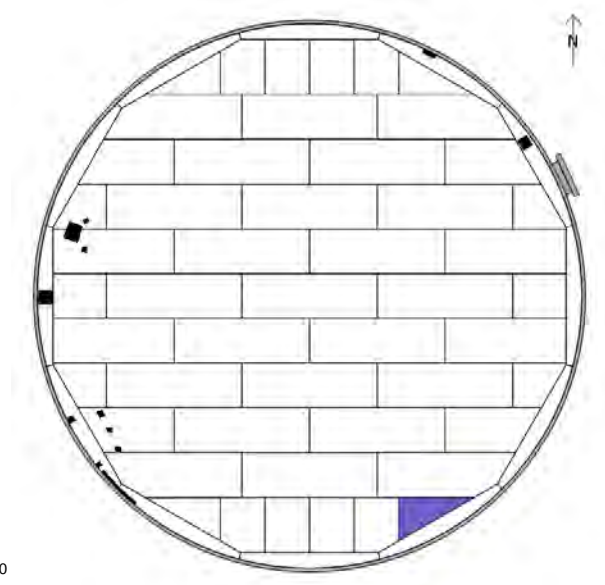
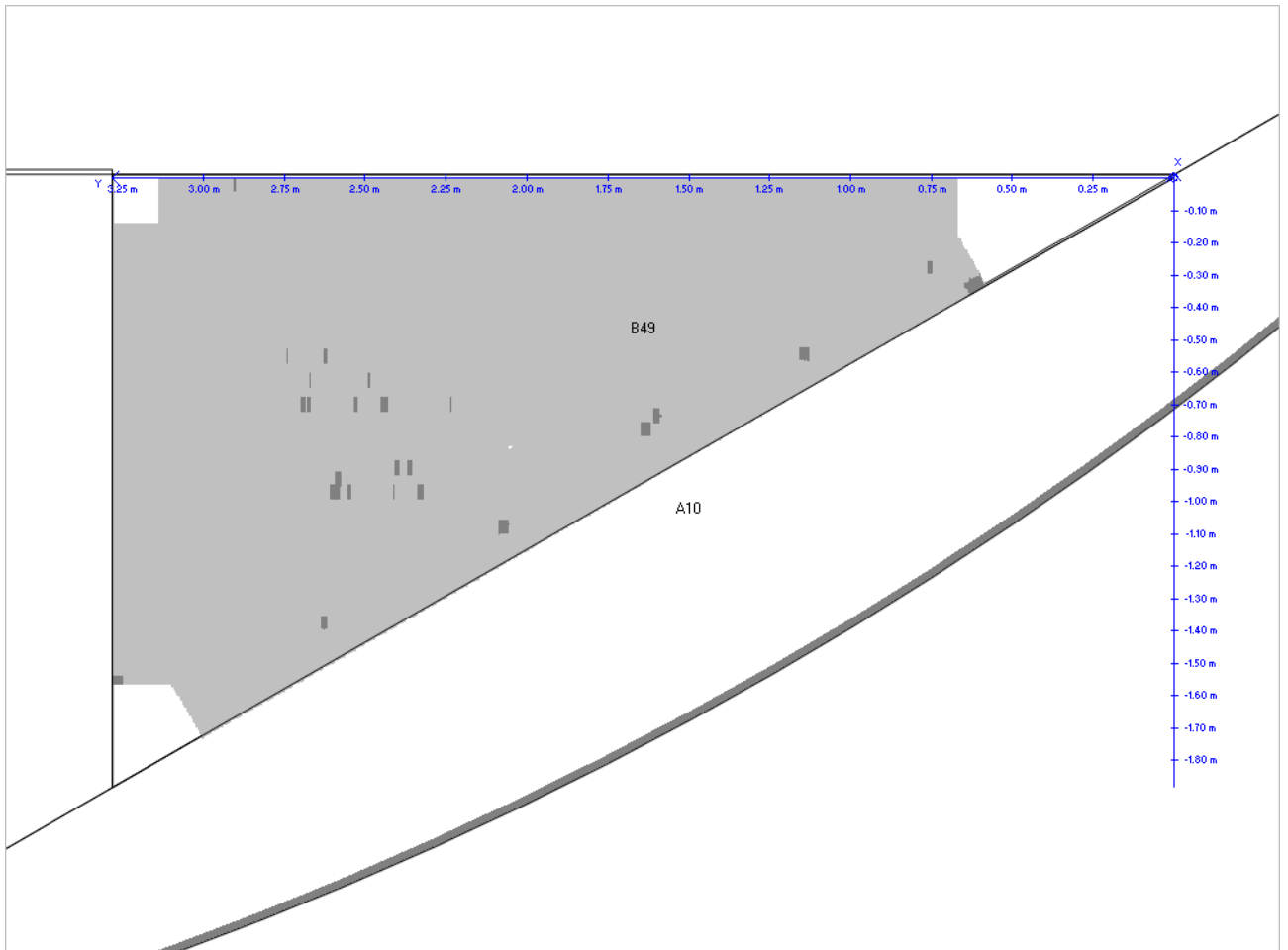



APPENDIX 03

Ultrasonic Thickness Gauging

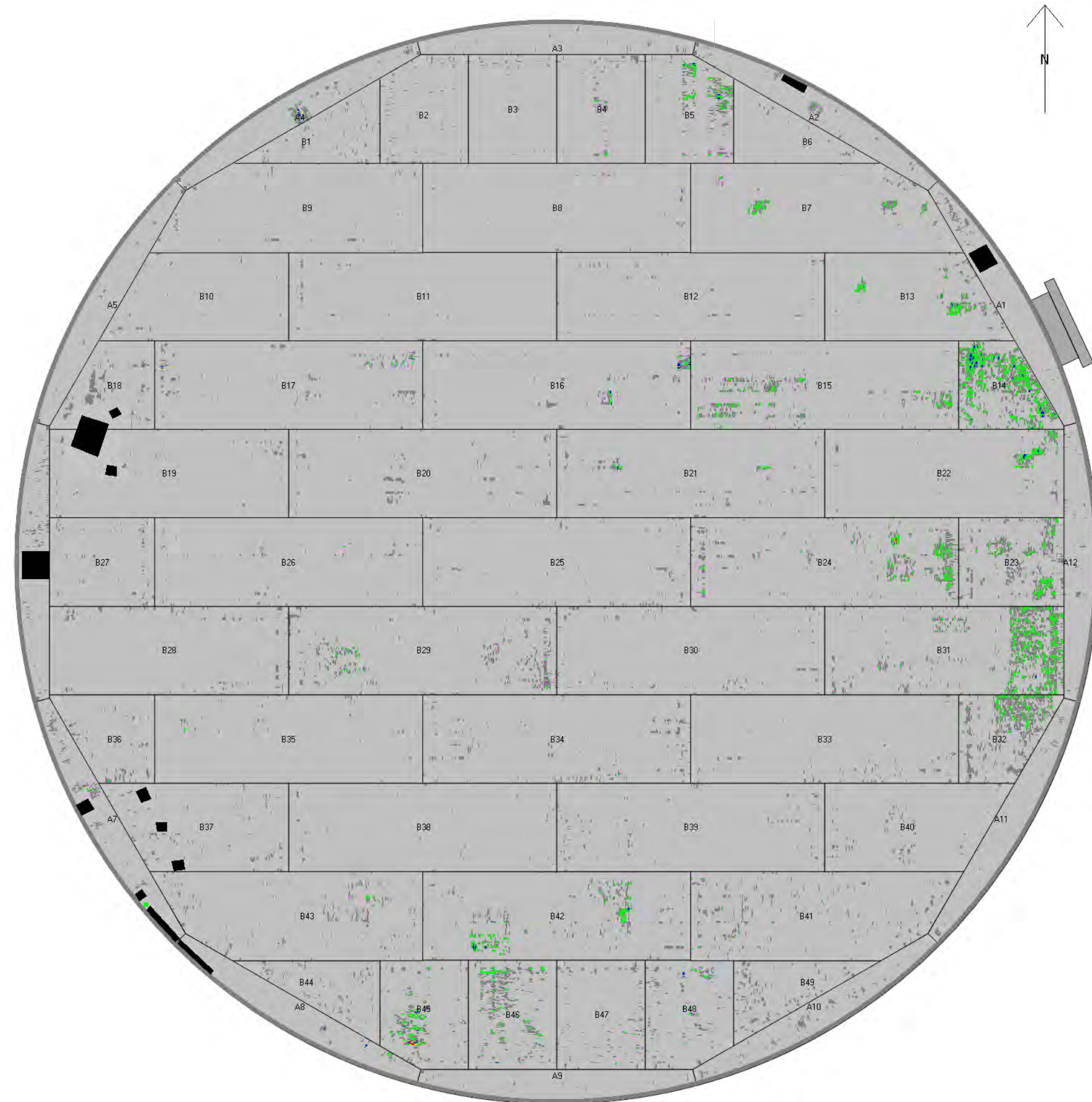

SLOFEC™

1 1

: Client a
 : Site b
 : Tank 123
 : 24.00 m
 : 452.39 qm
 : 8.00 mm
 : 9.60 mm
 : 0.00 mm
 : 0.00 mm
 : Jxx86
 : K0xx-16
 : 03/05/2016

Combined UT & Underside-Differential

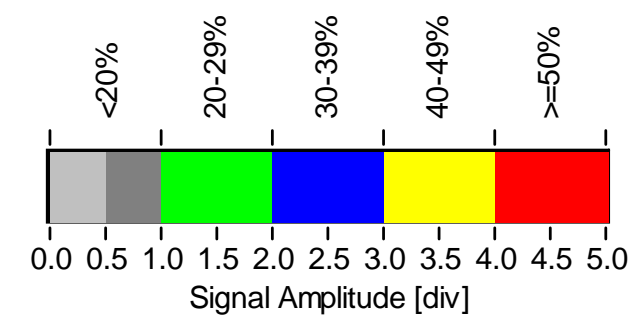

<ul style="list-style-type: none"> : Client a : Site b : 03/05/2016 : A 1 	<ul style="list-style-type: none"> : Tank 123 : K0xx-16 : Jxx86
---	--

Ultrasonic Thickness Readings

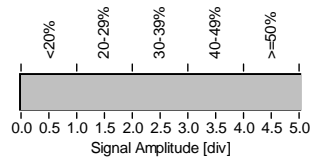
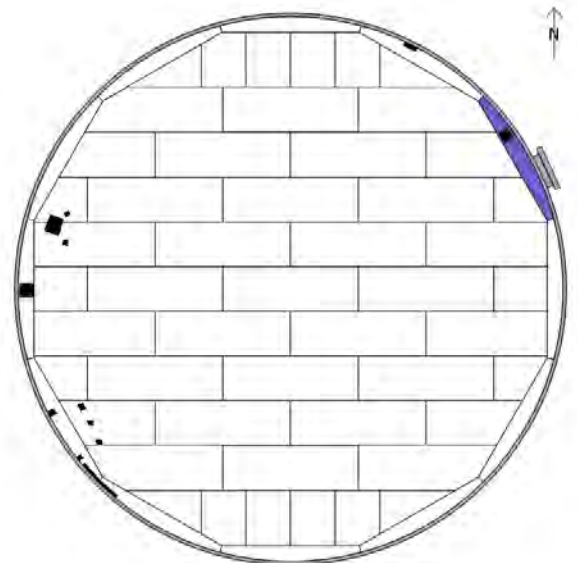
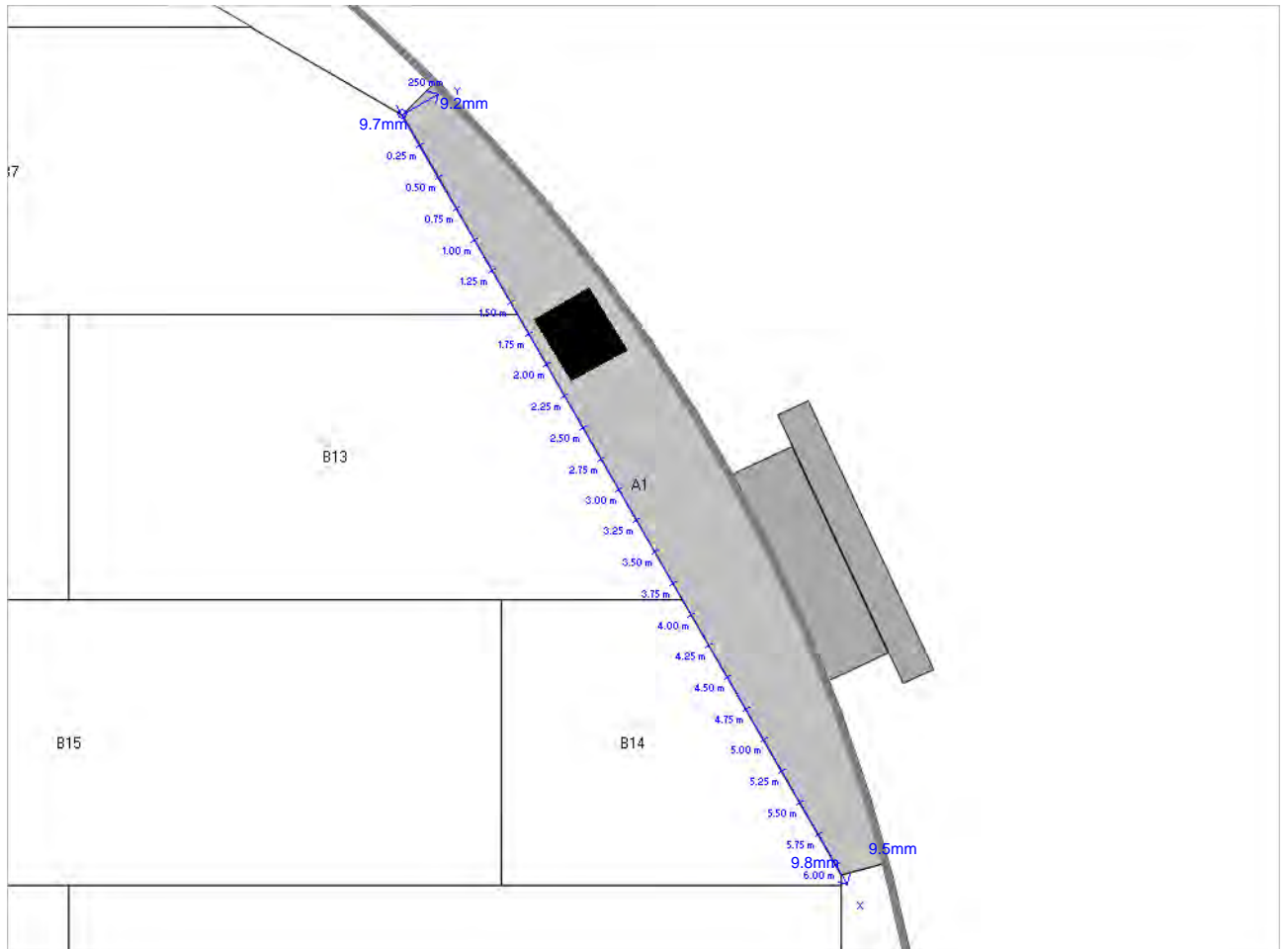

<ul style="list-style-type: none"> : Client a : Site b : 03/05/2016 : A 2 	<ul style="list-style-type: none"> : Tank 123 : K0xx-16 : Jxx86
---	--

Ultrasonic Thickness Readings

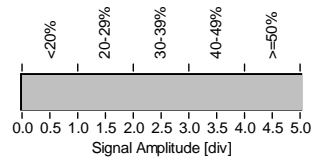
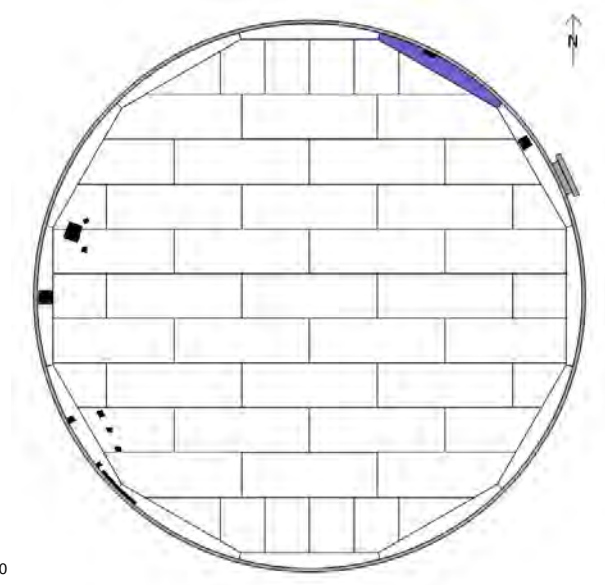
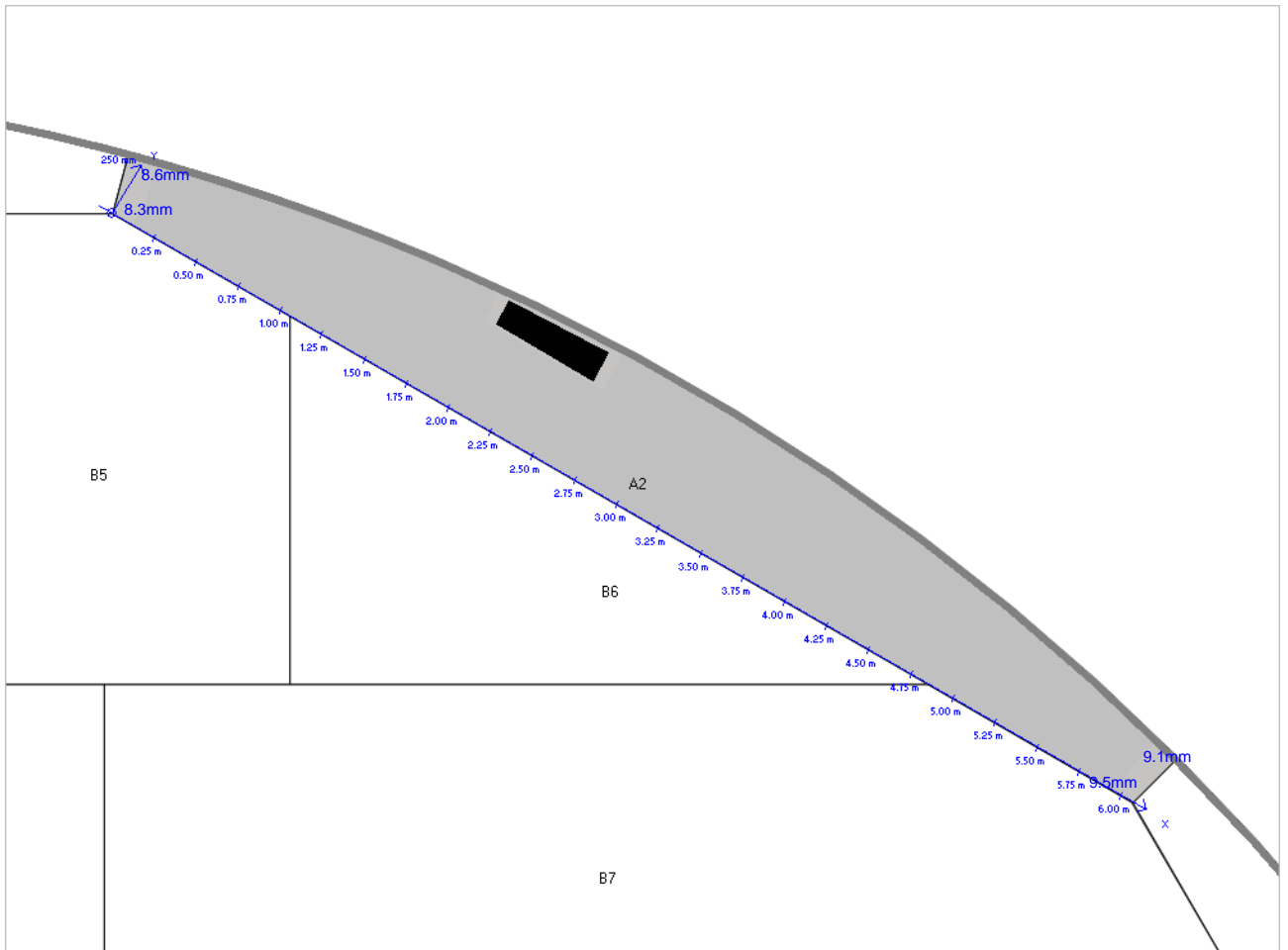

<ul style="list-style-type: none"> : Client a : Site b : 03/05/2016 : A 3 	<ul style="list-style-type: none"> : Tank 123 : K0xx-16 : Jxx86
---	--

Ultrasonic Thickness Readings

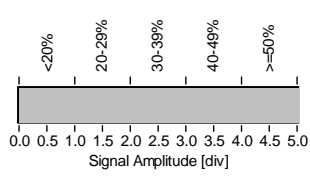
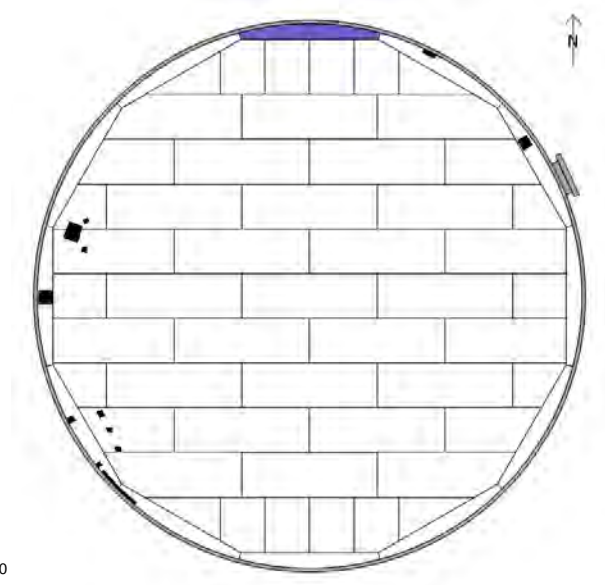
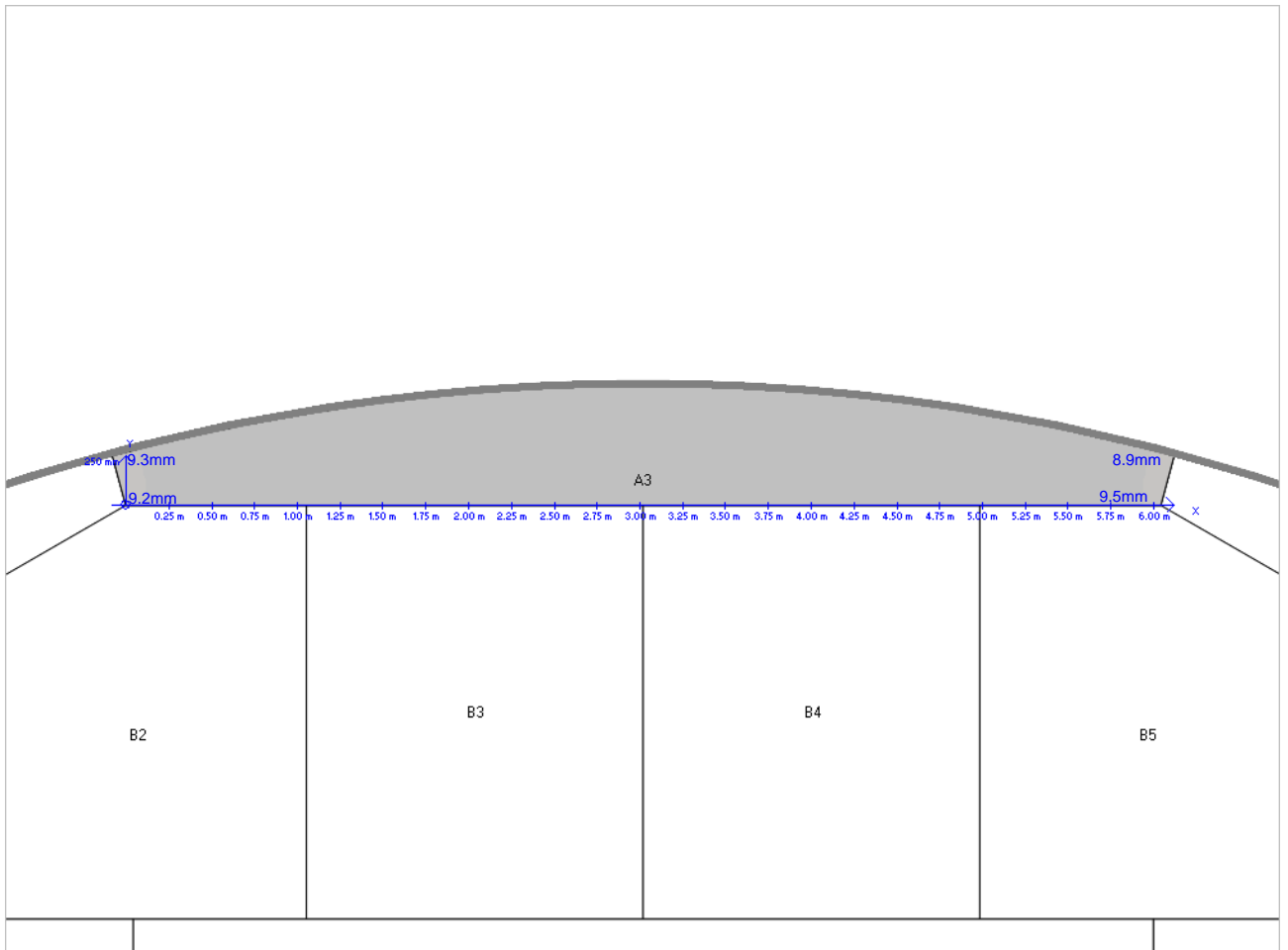

: Client a	: Tank 123
: Site b	: K0xx-16
: 03/05/2016	: Jxx86
: A 4	

Ultrasonic Thickness Readings

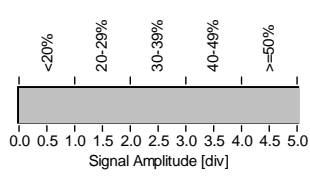
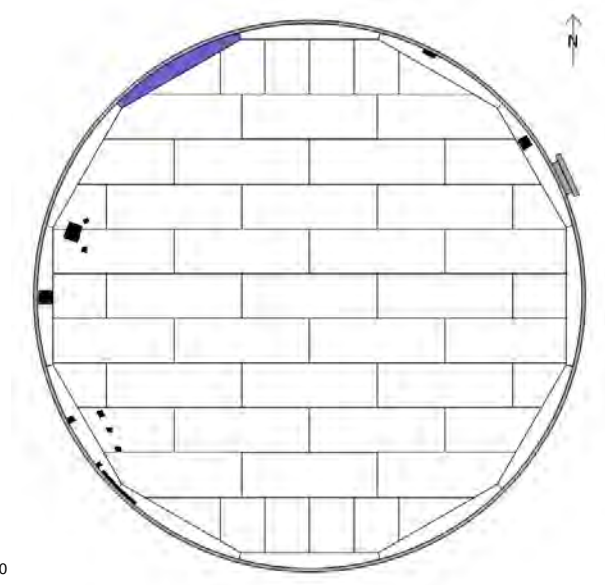
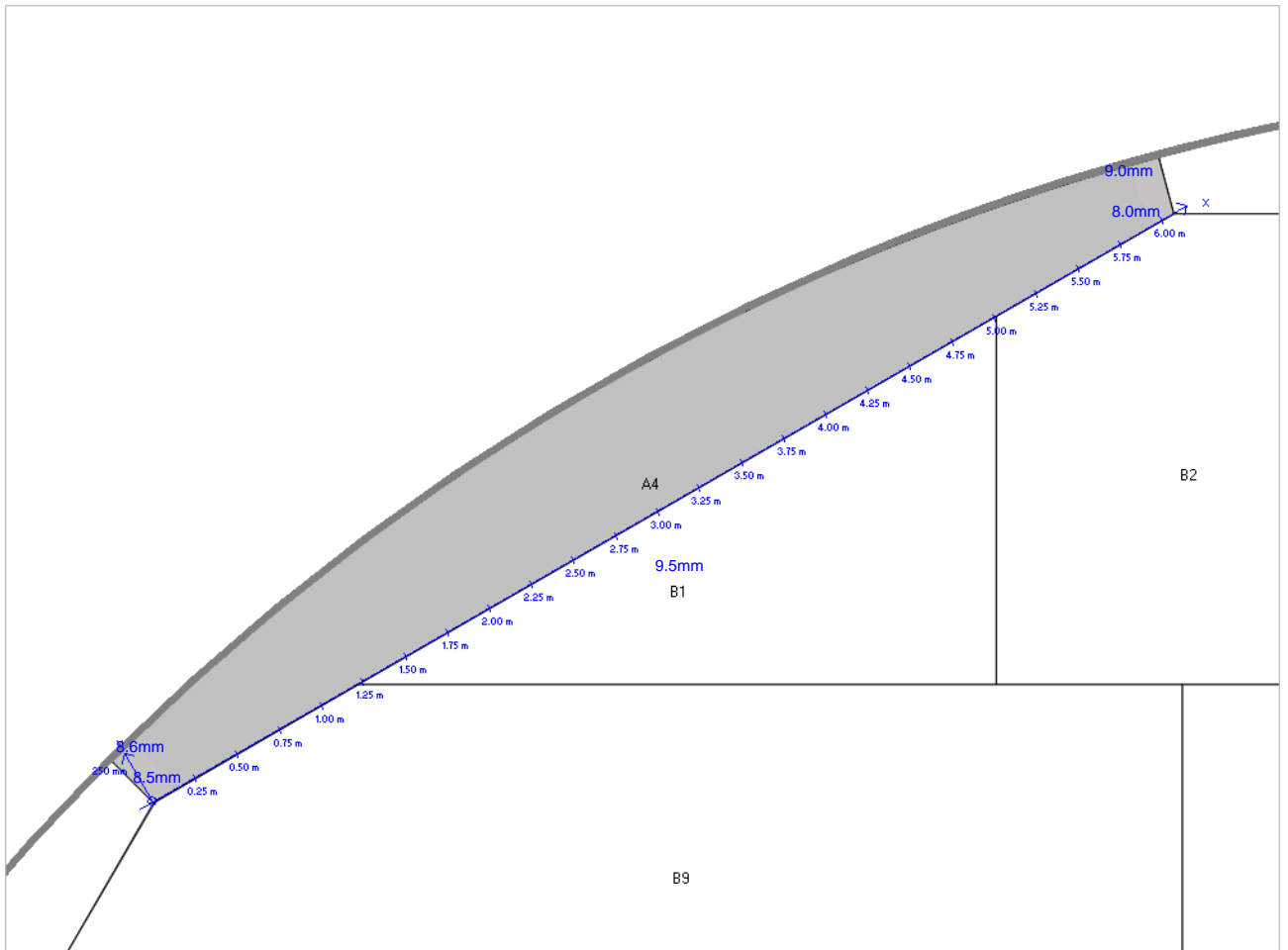

: Client a	: Tank 123
: Site b	: K0xx-16
: 03/05/2016	: Jxx86
: A 5	

Ultrasonic Thickness Readings

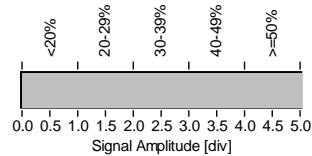
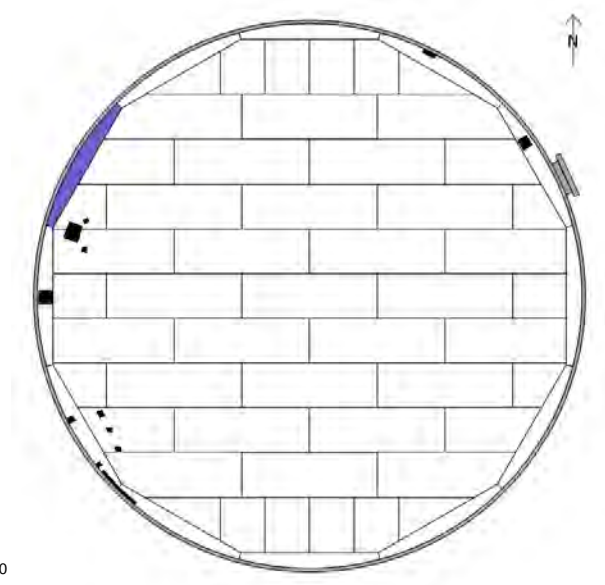
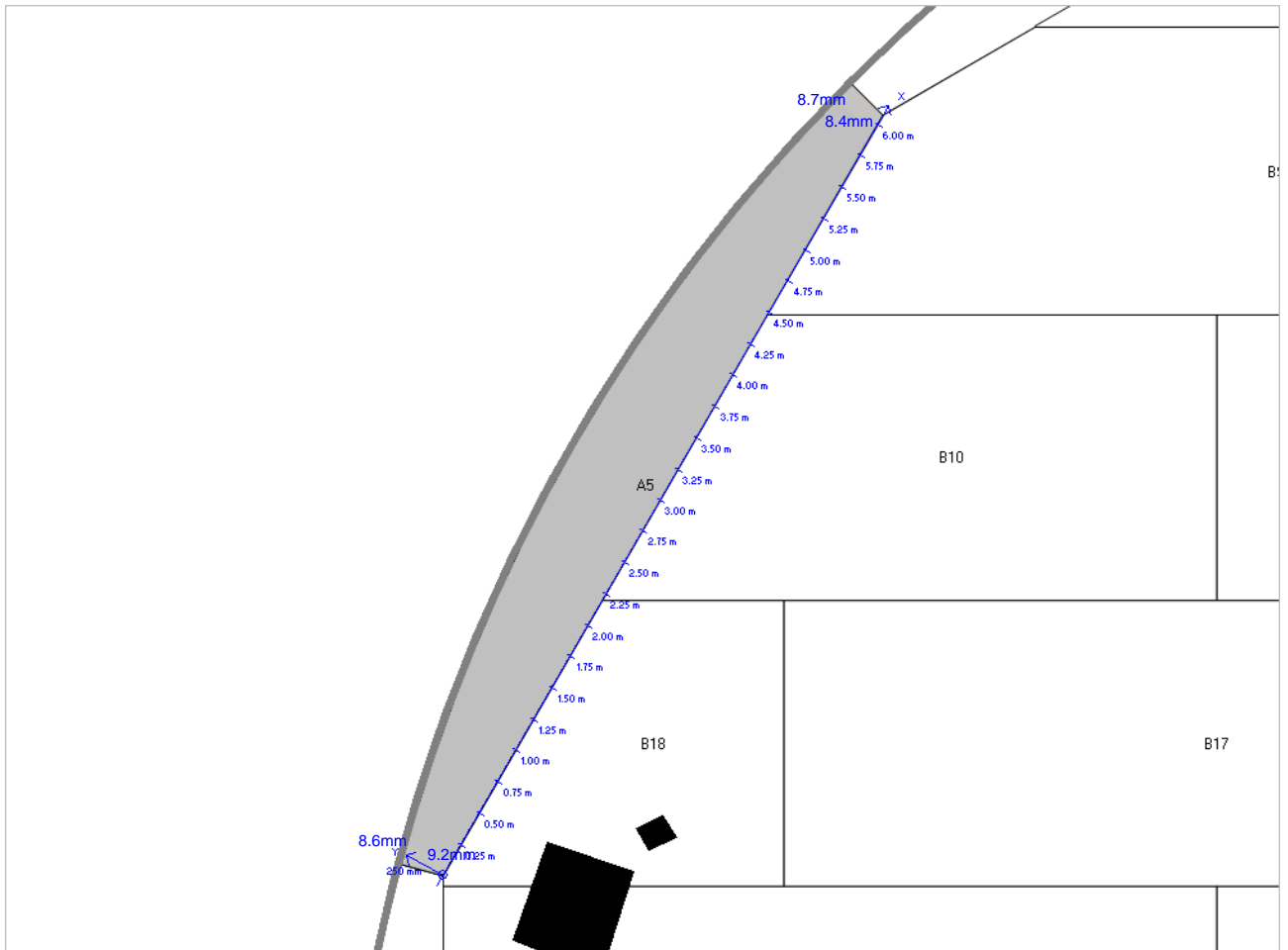

<ul style="list-style-type: none"> : Client a : Site b : 03/05/2016 : A 6 	<ul style="list-style-type: none"> : Tank 123 : K0xx-16 : Jxx86
---	--

Ultrasonic Thickness Readings

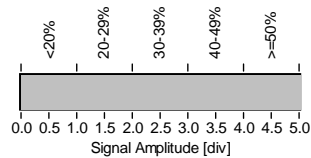
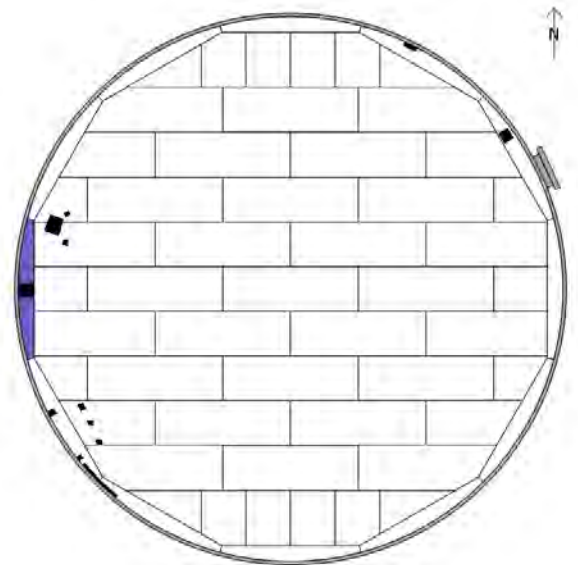
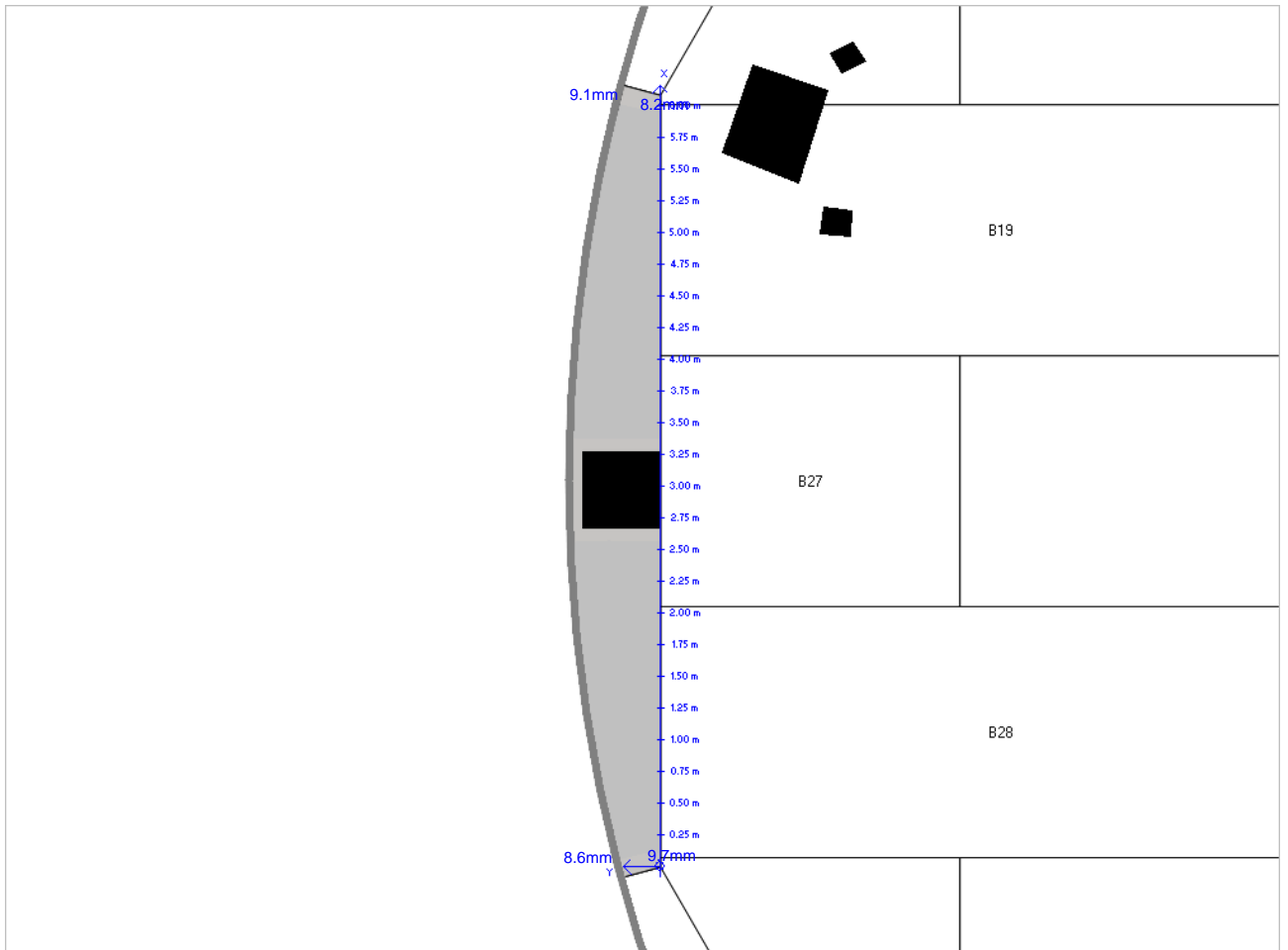

<ul style="list-style-type: none"> : Client a : Site b : 03/05/2016 : A 7 	<ul style="list-style-type: none"> : Tank 123 : K0xx-16 : Jxx86
---	--

Ultrasonic Thickness Readings

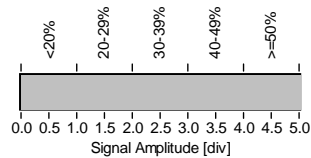
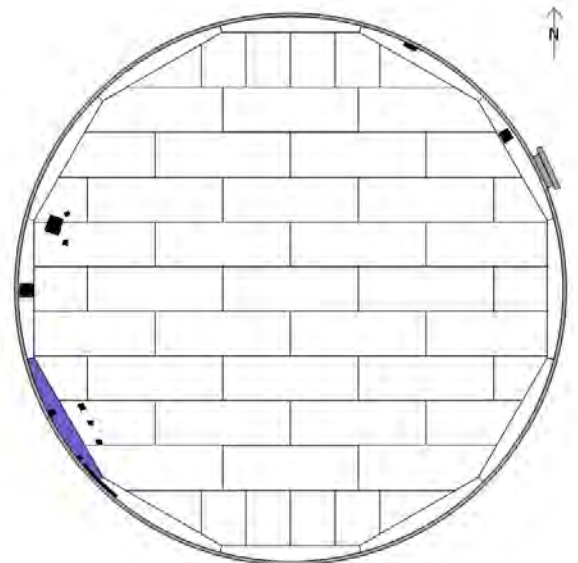
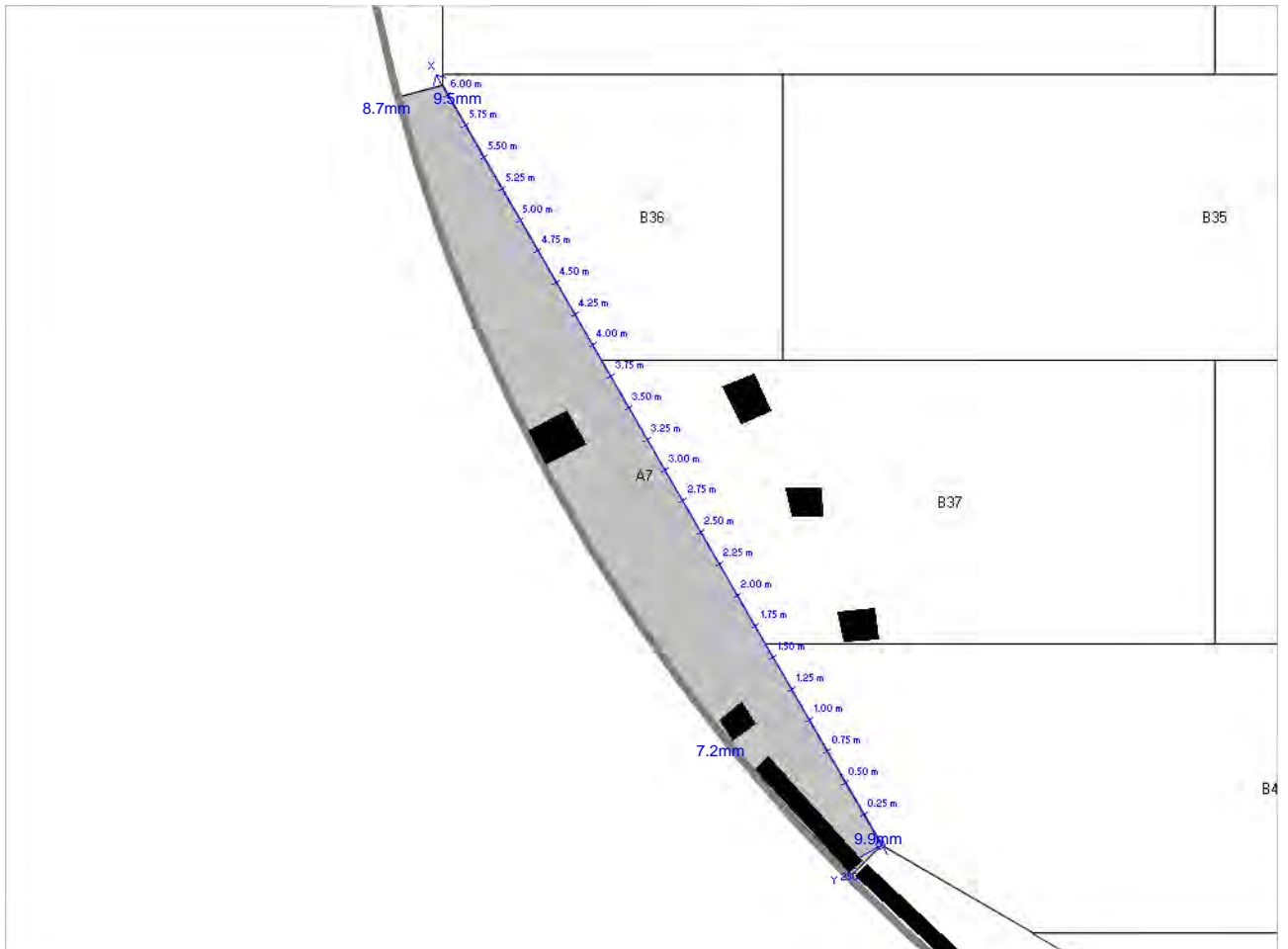

: Client x	: Tank 123
: Site b	: K0xx-16
: 03/05/2016	: Jxx86
: A 8	

Ultrasonic Thickness Readings

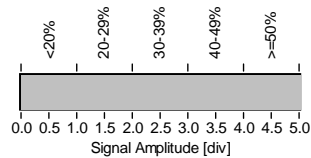
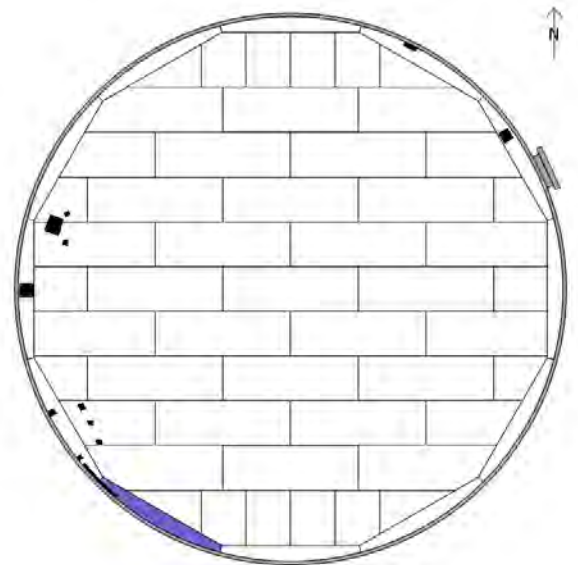
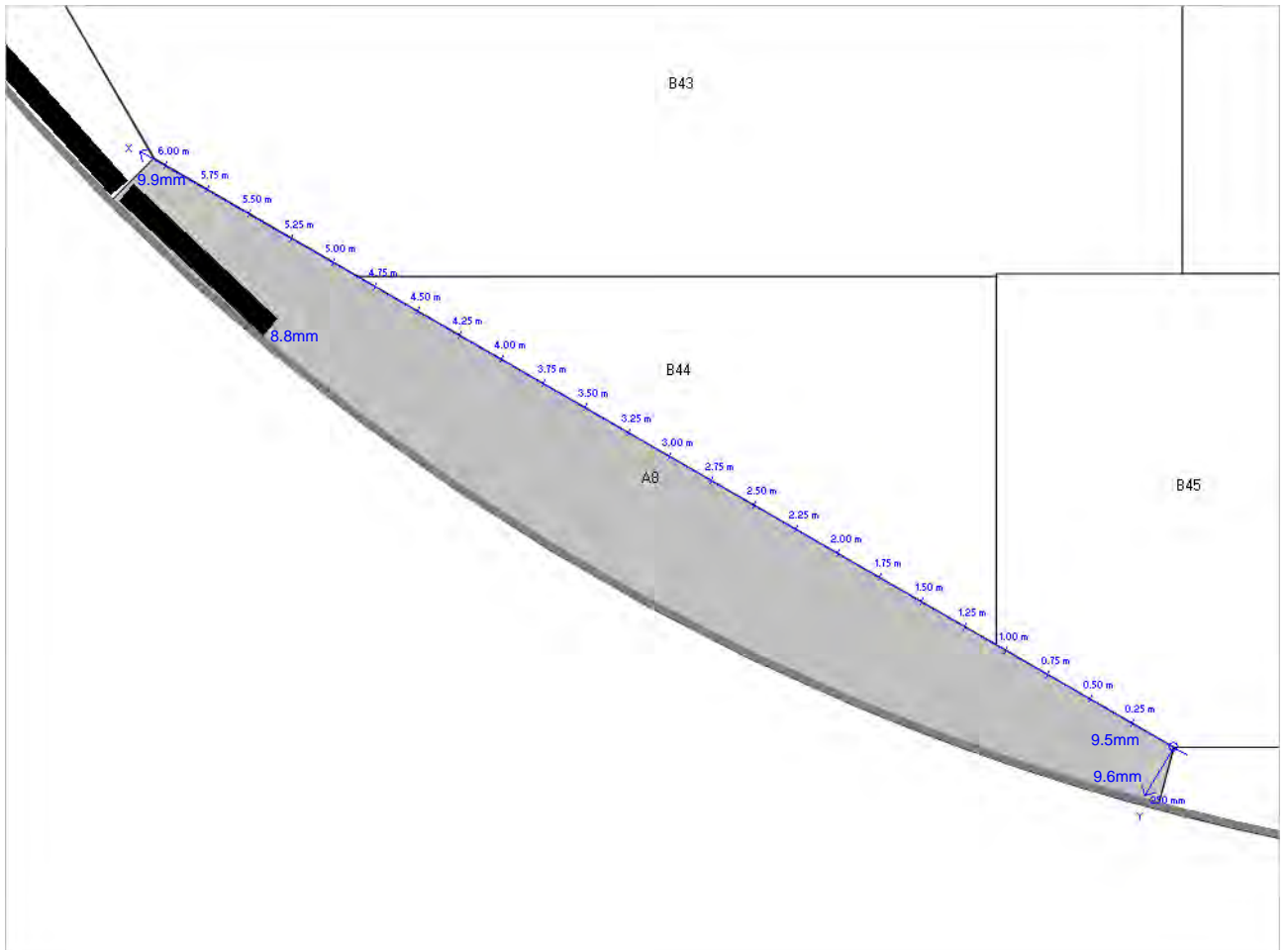

: Client a : Site b : 03/05/2016 : A 9	: Tank 123 : K0xx-16 : Jxx86
---	------------------------------------

Ultrasonic Thickness Readings

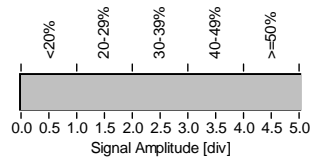
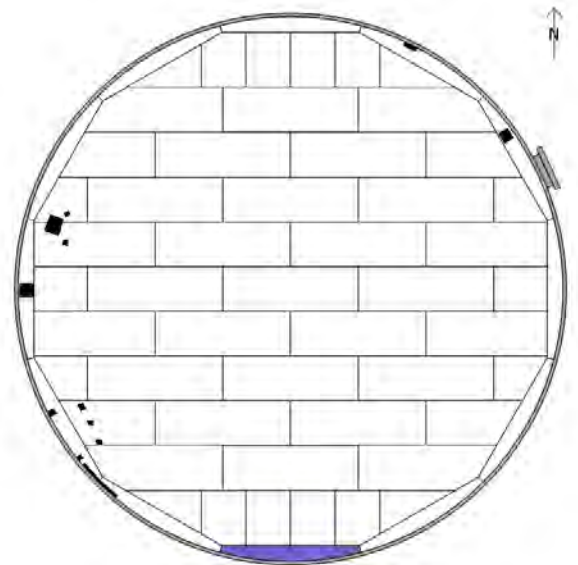
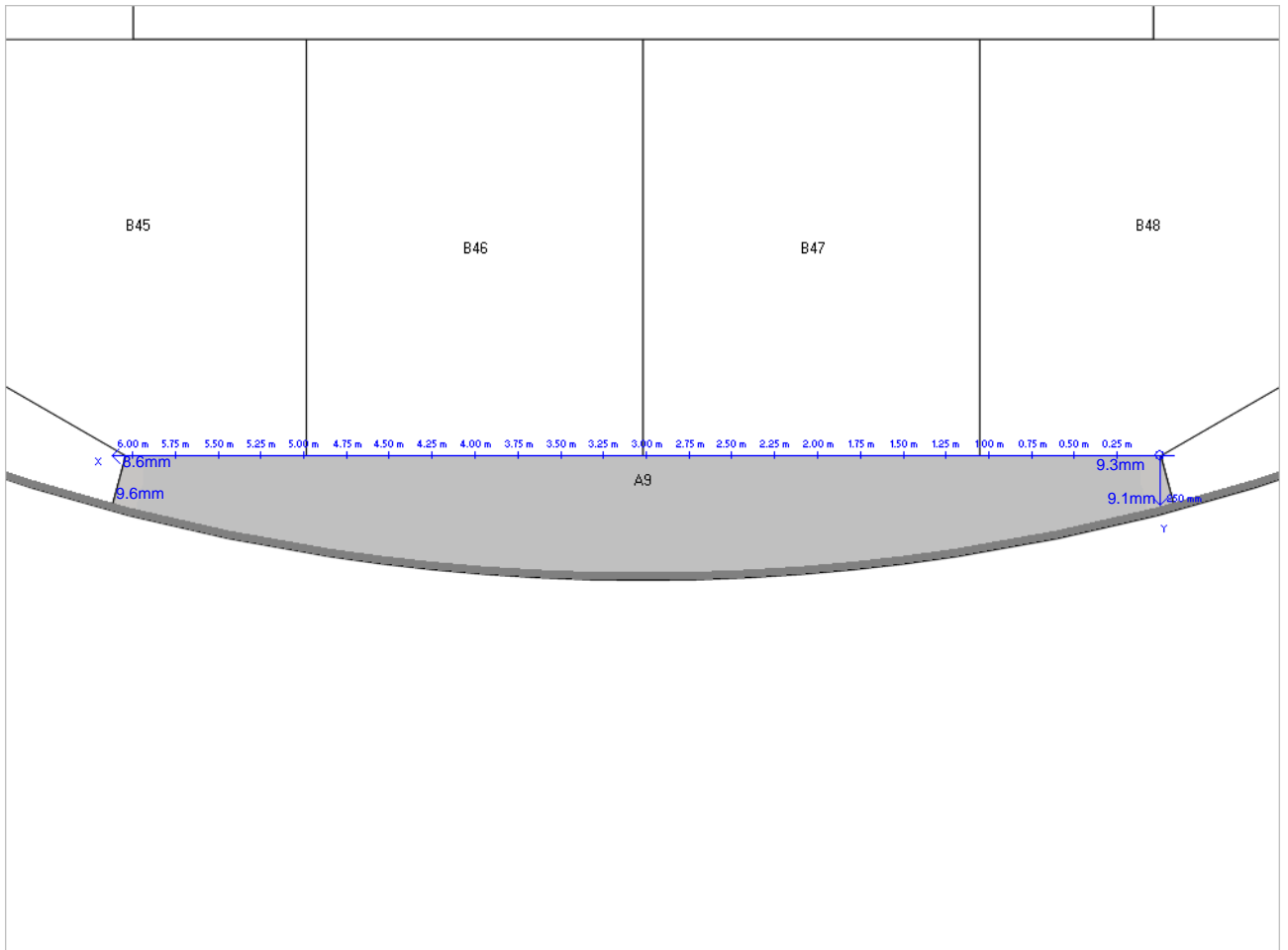

: Client a	: Tank 123
: Site b	: K0xx-16
: 03/05/2016	: Jxx86
: A 10	

Ultrasonic Thickness Readings

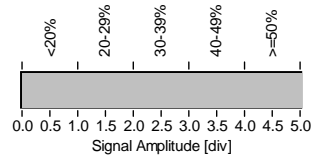
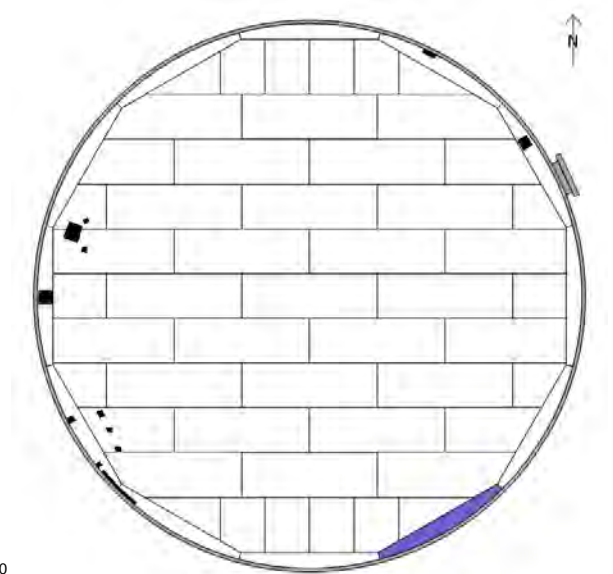
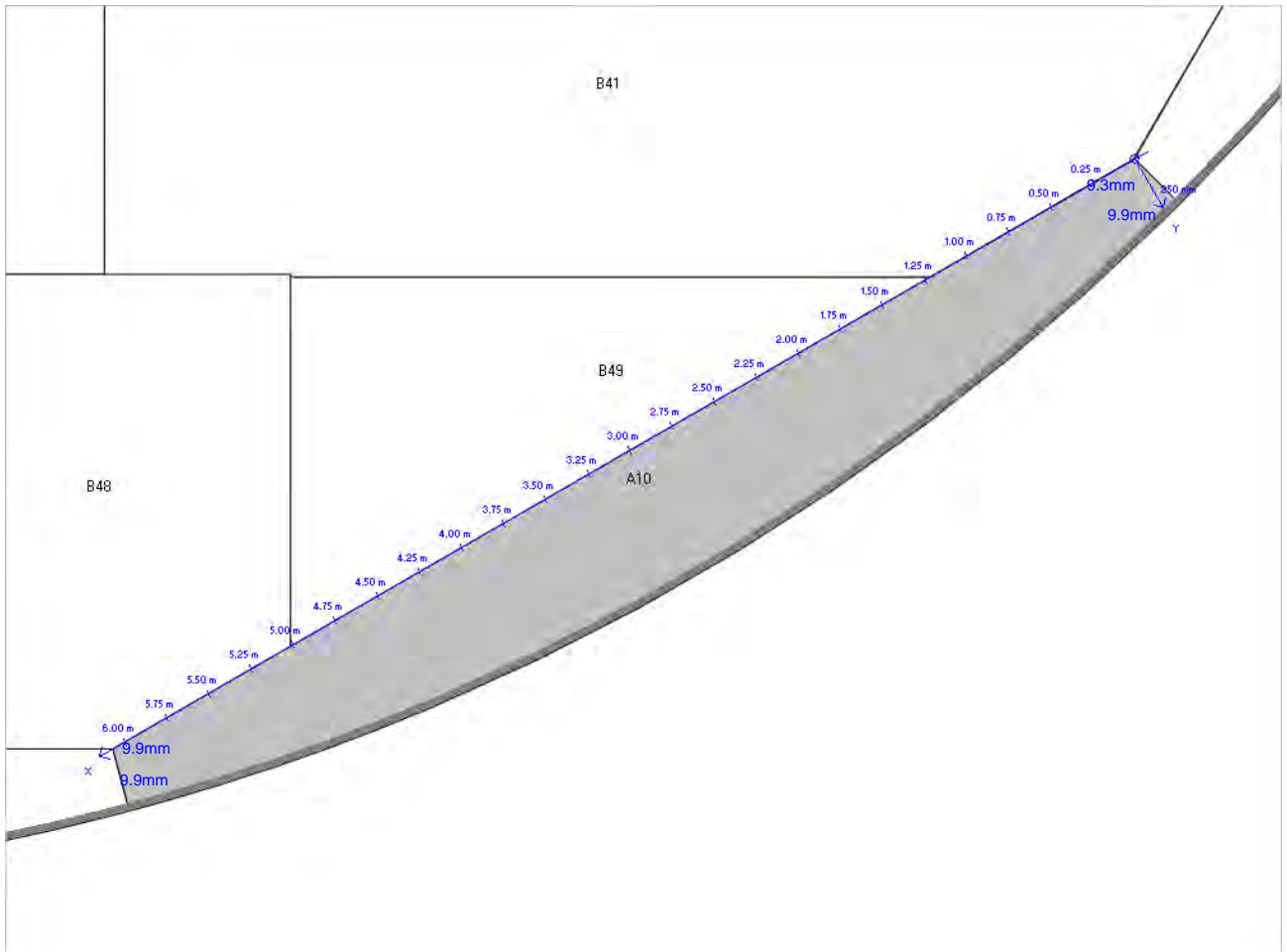

<ul style="list-style-type: none"> : Client a : Site b : 03/05/2016 : A 11 	<ul style="list-style-type: none"> : Tank 123 : K0xx-16 : Jxx86
--	--

Ultrasonic Thickness Readings

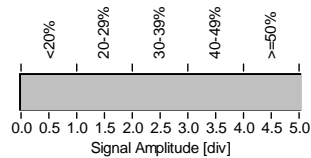
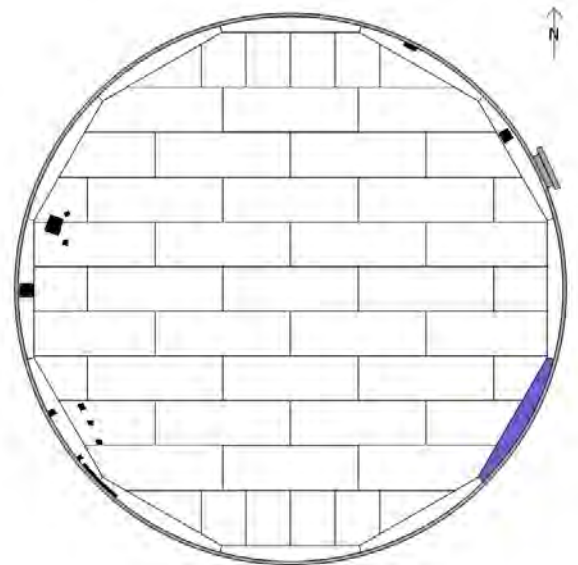
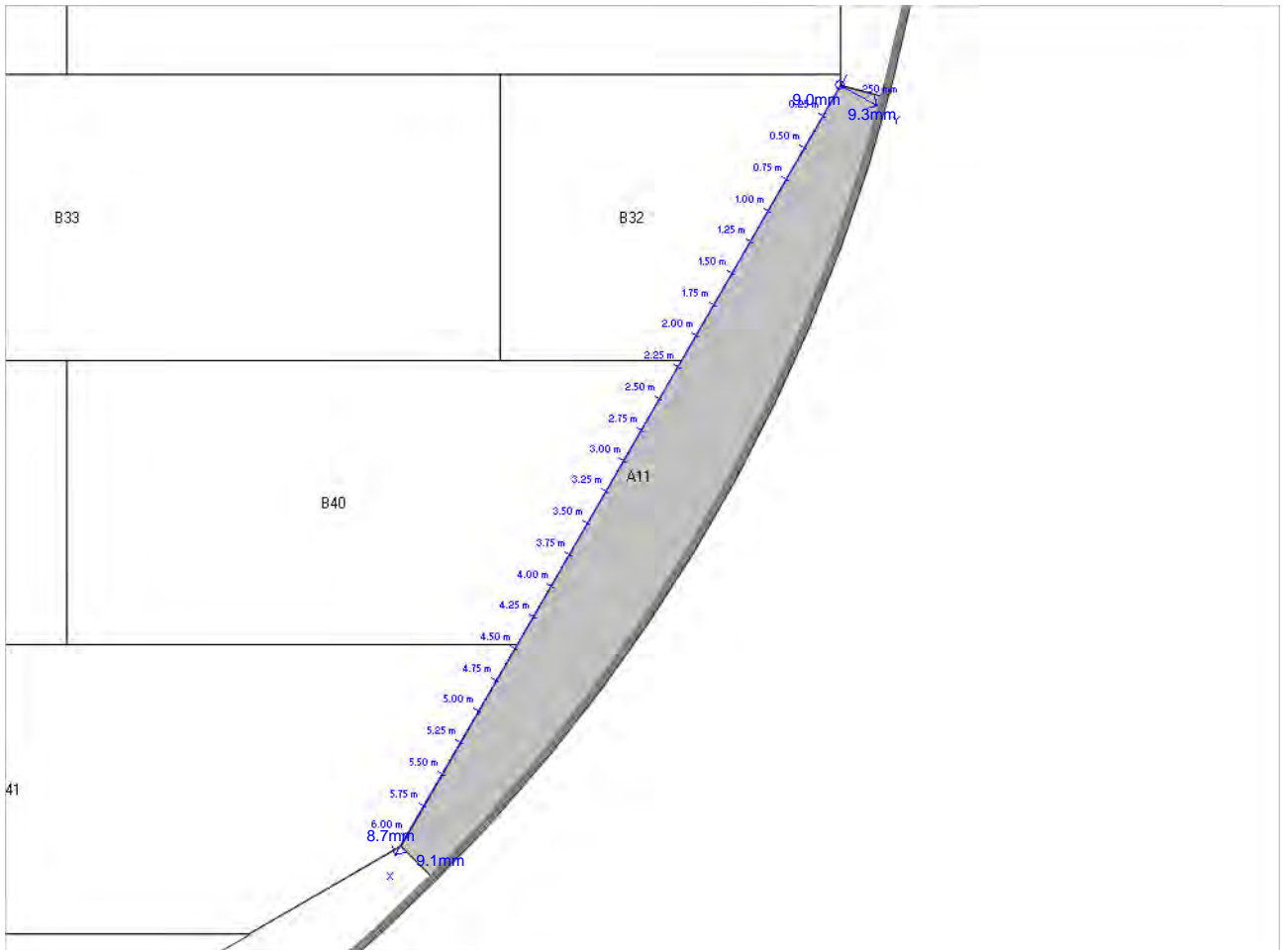

: Client a : Site b : 03/05/2016 : A 12	: Tank 123 : K0xx-16 : Jxx86
--	------------------------------------

Ultrasonic Thickness Readings

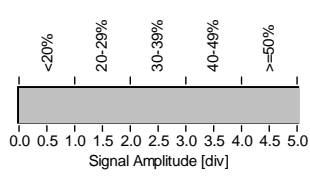
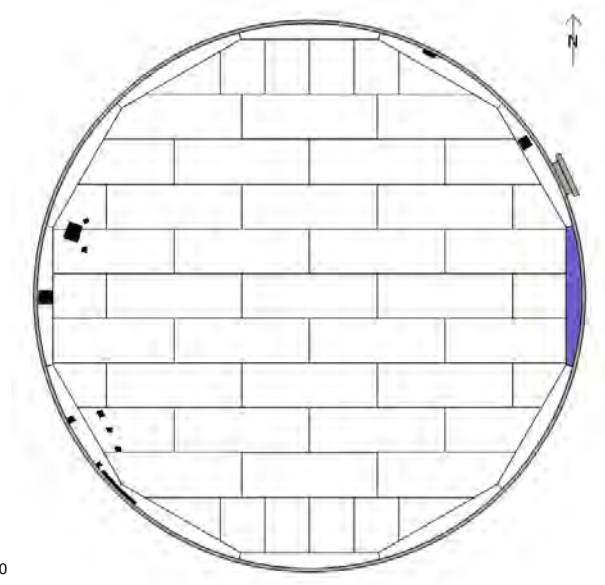
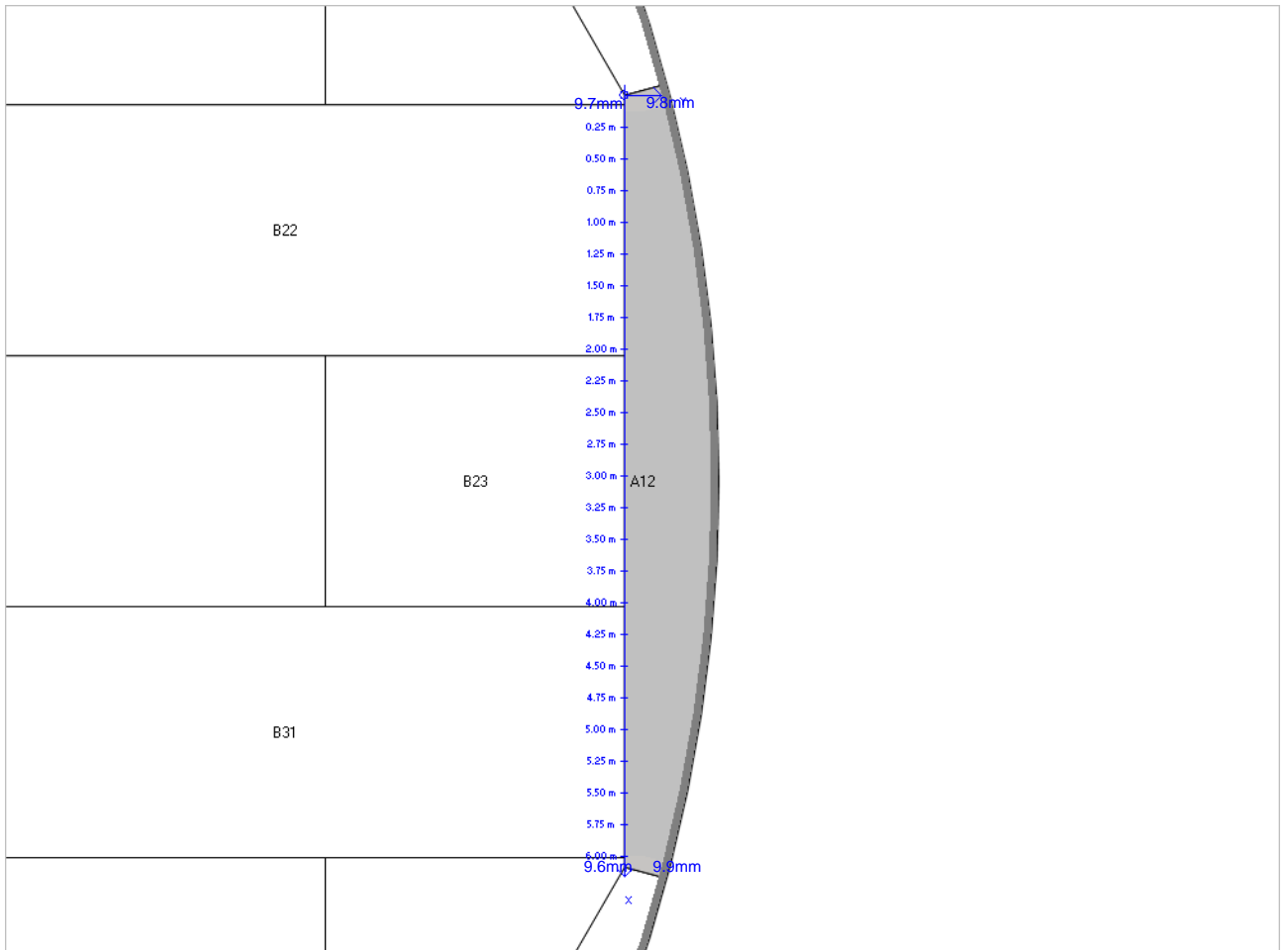

<ul style="list-style-type: none"> : Client a : Site b : 03/05/2016 : B 1 	<ul style="list-style-type: none"> : Tank 123 : K0xx-16 : Jxx86
---	--

Ultrasonic Thickness Readings

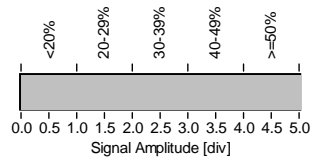
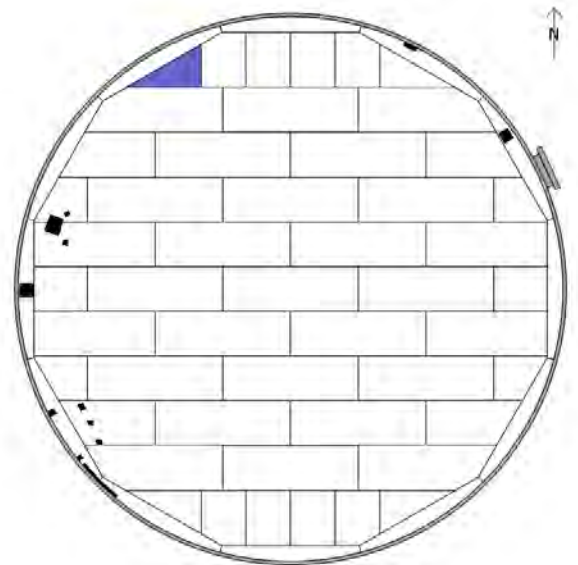
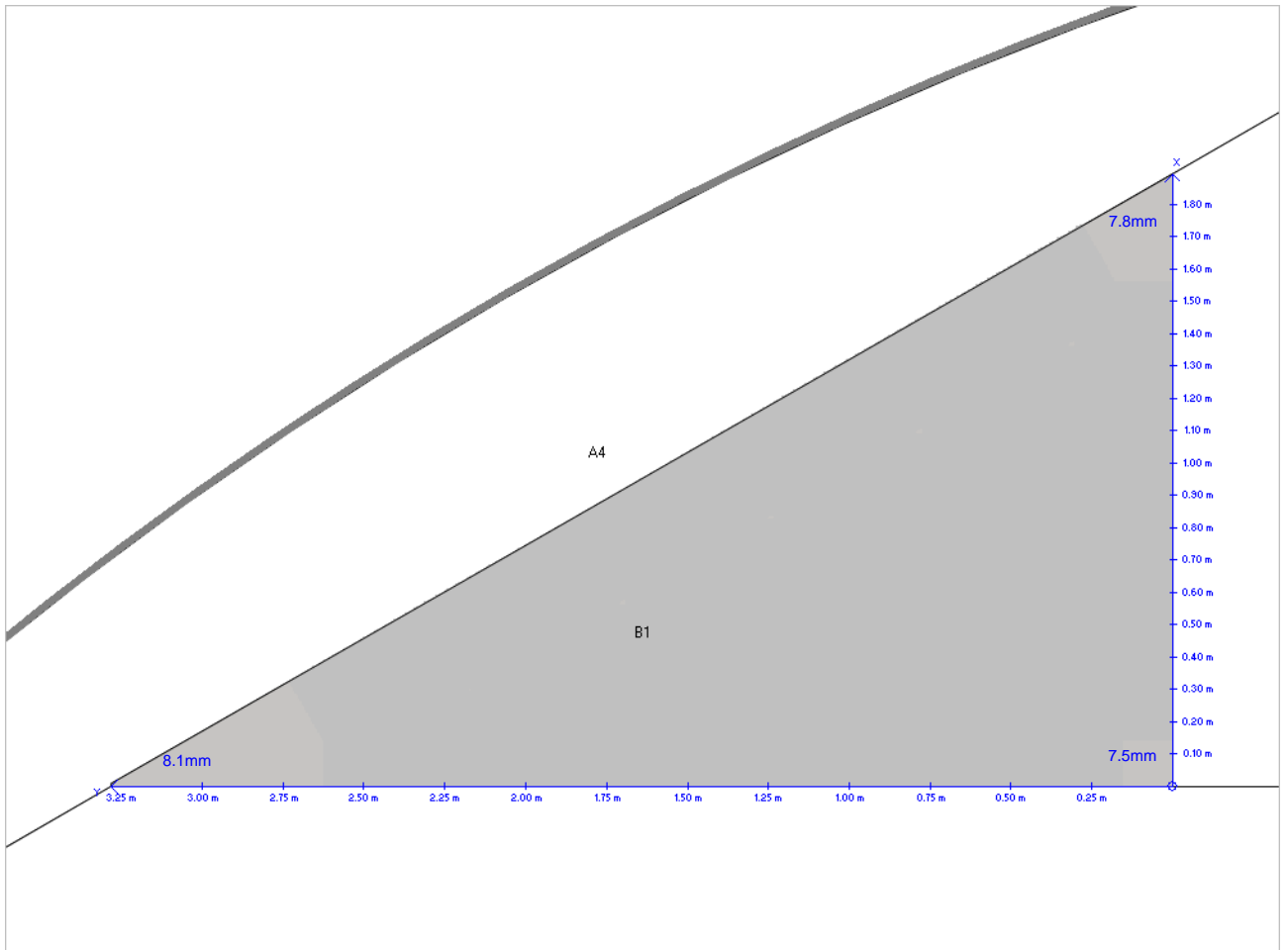

<ul style="list-style-type: none"> : Client a : Site b : 03/05/2016 : B 2 	<ul style="list-style-type: none"> : Tank 123 : K0xx-16 : Jxx86
---	--

Ultrasonic Thickness Readings

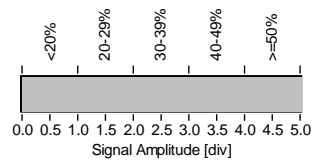
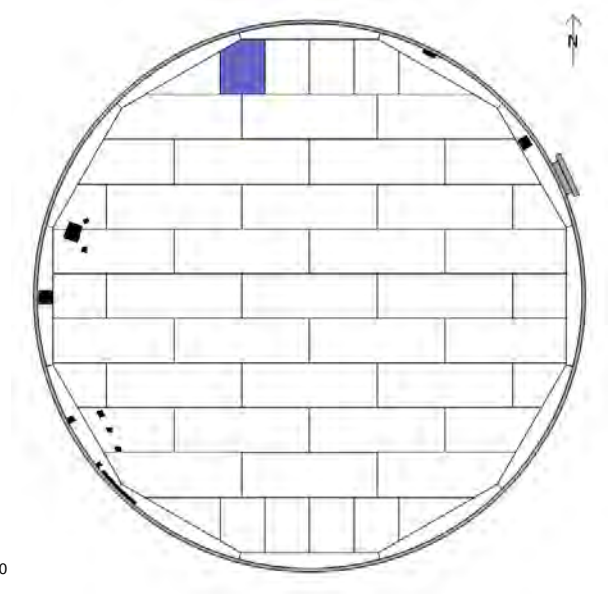
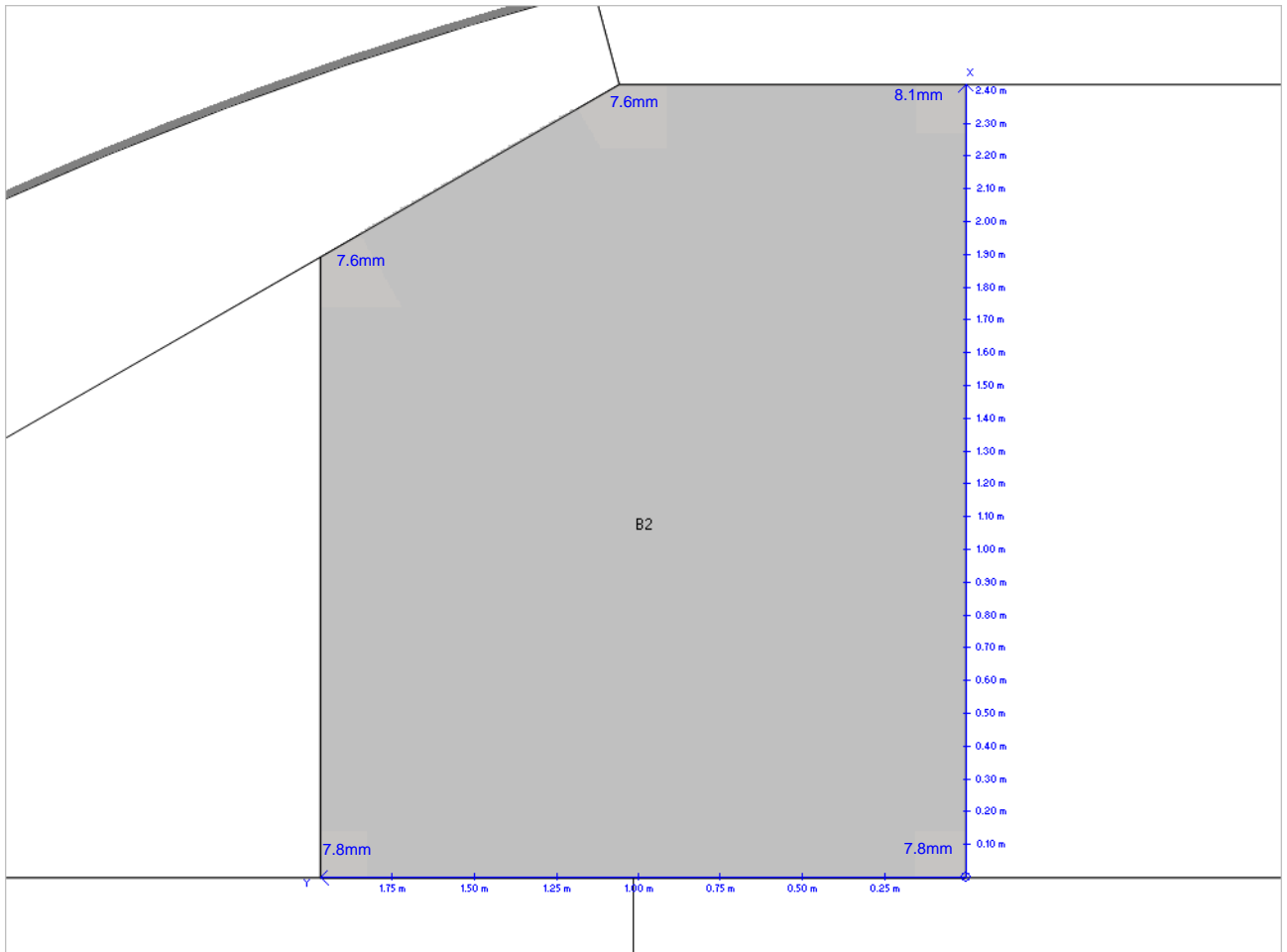

: Client a : Site b : 03/05/2016 : B 3	: Tank 123 : K0xx-16 : Jxx86
---	------------------------------------

Ultrasonic Thickness Readings

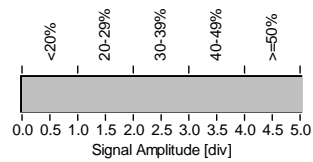
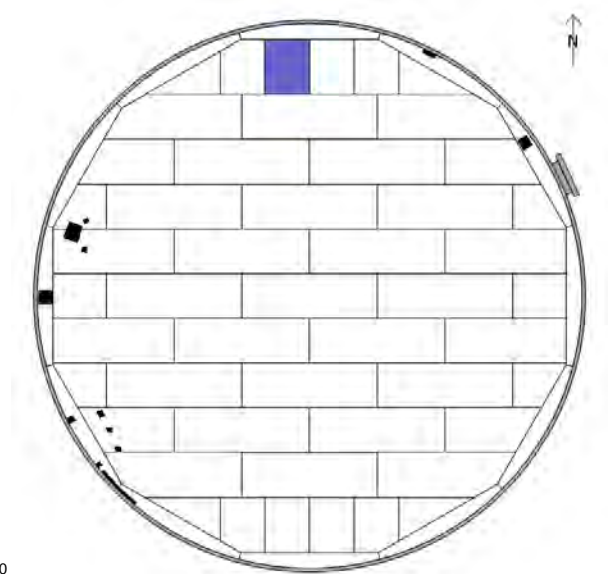
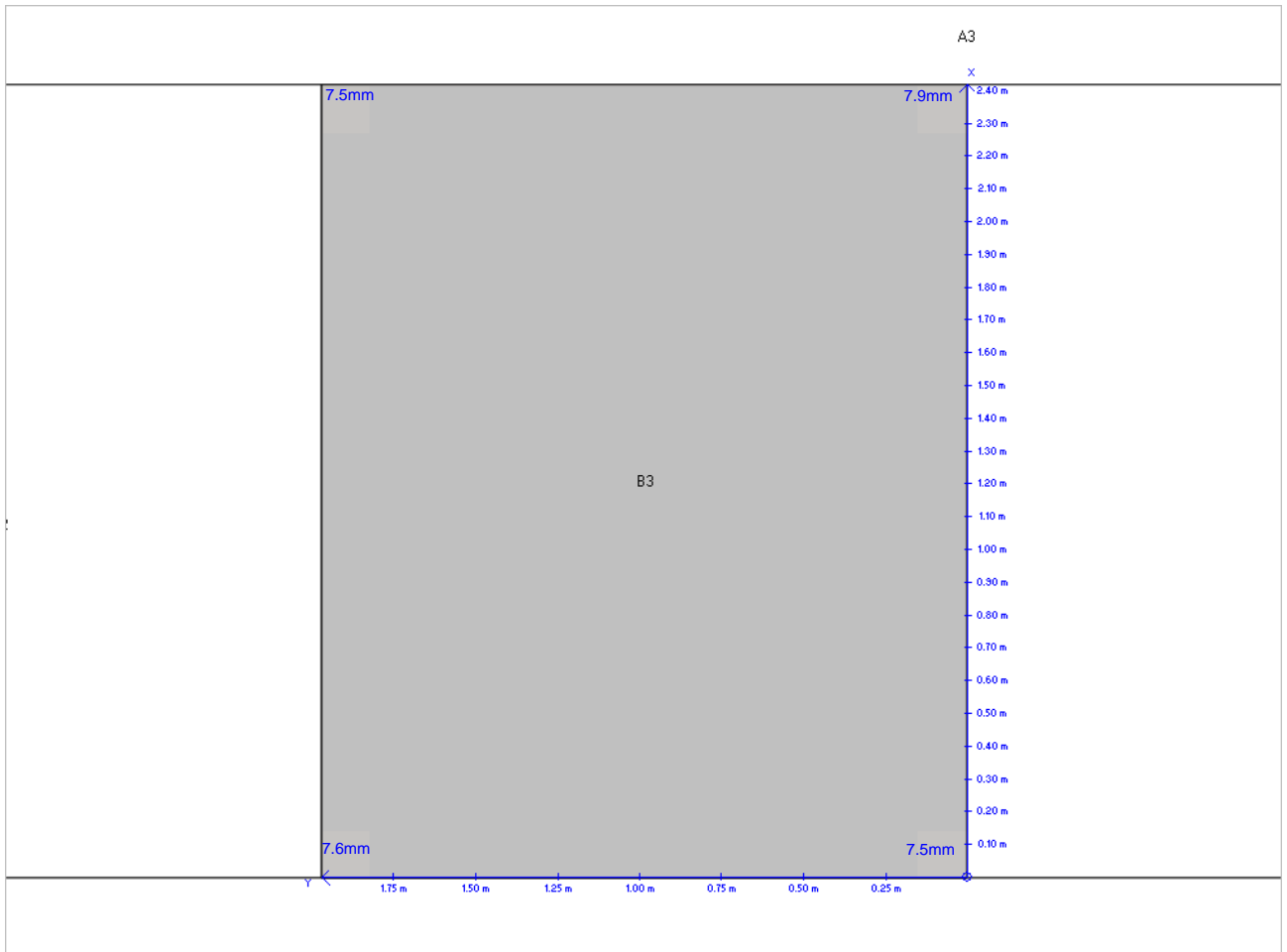

: Client a : Site b : 03/05/2016 : B 4	: Tank 123 : K0xx-16 : Jxx86
---	------------------------------------

Ultrasonic Thickness Readings

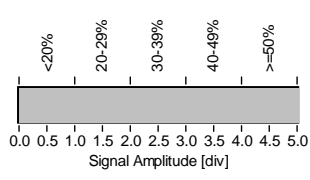
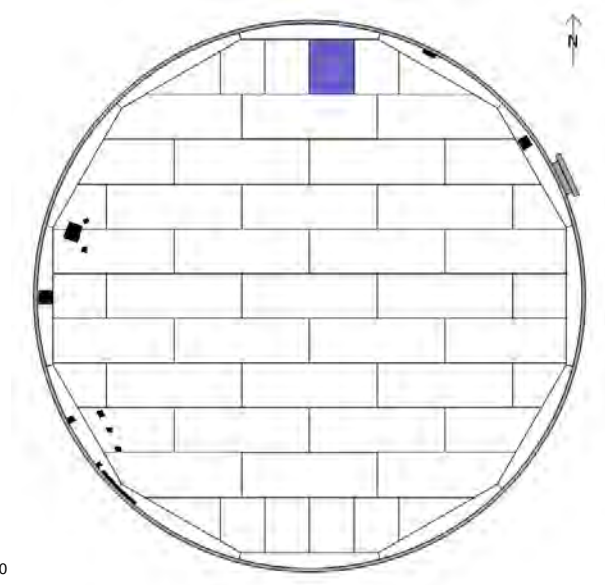
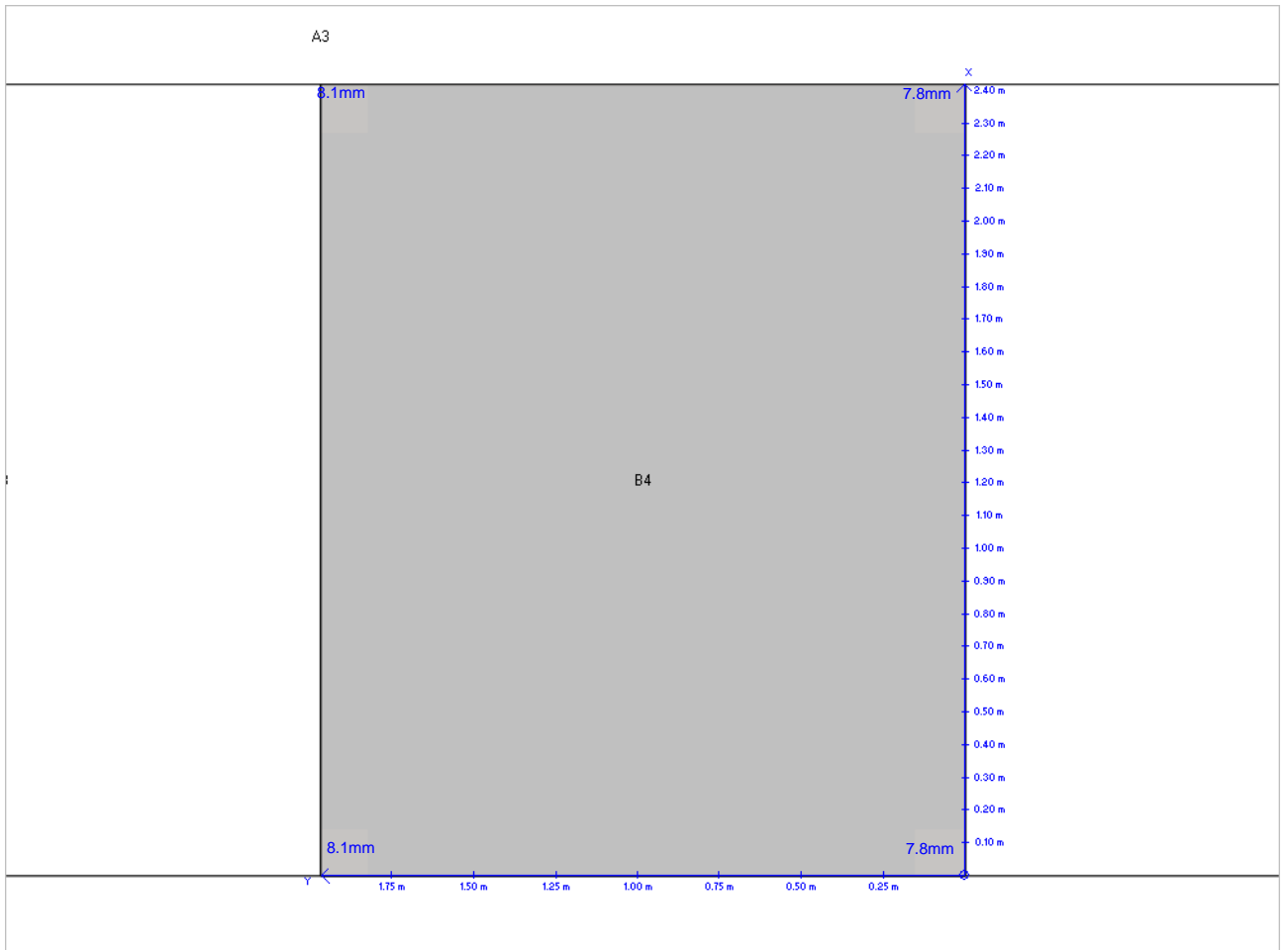

<ul style="list-style-type: none"> : Client a : Site b : 03/05/2016 : B 5 	<ul style="list-style-type: none"> : Tank 123 : K0xx-16 : Jxx86
---	--

Ultrasonic Thickness Readings

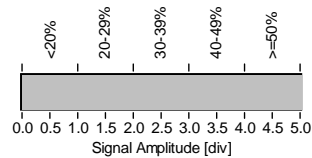
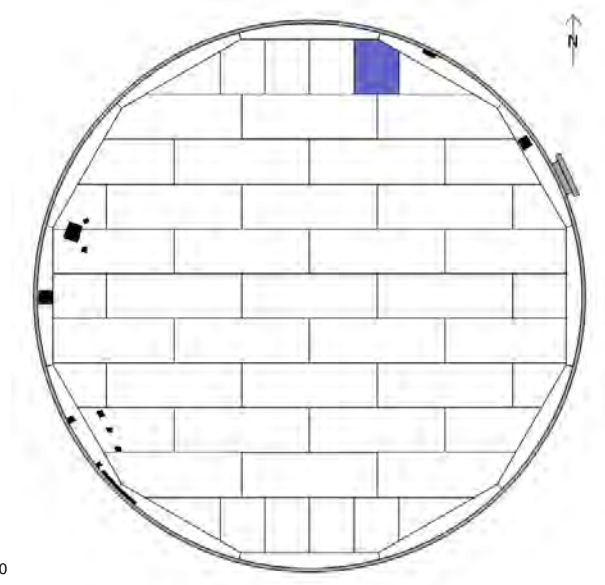
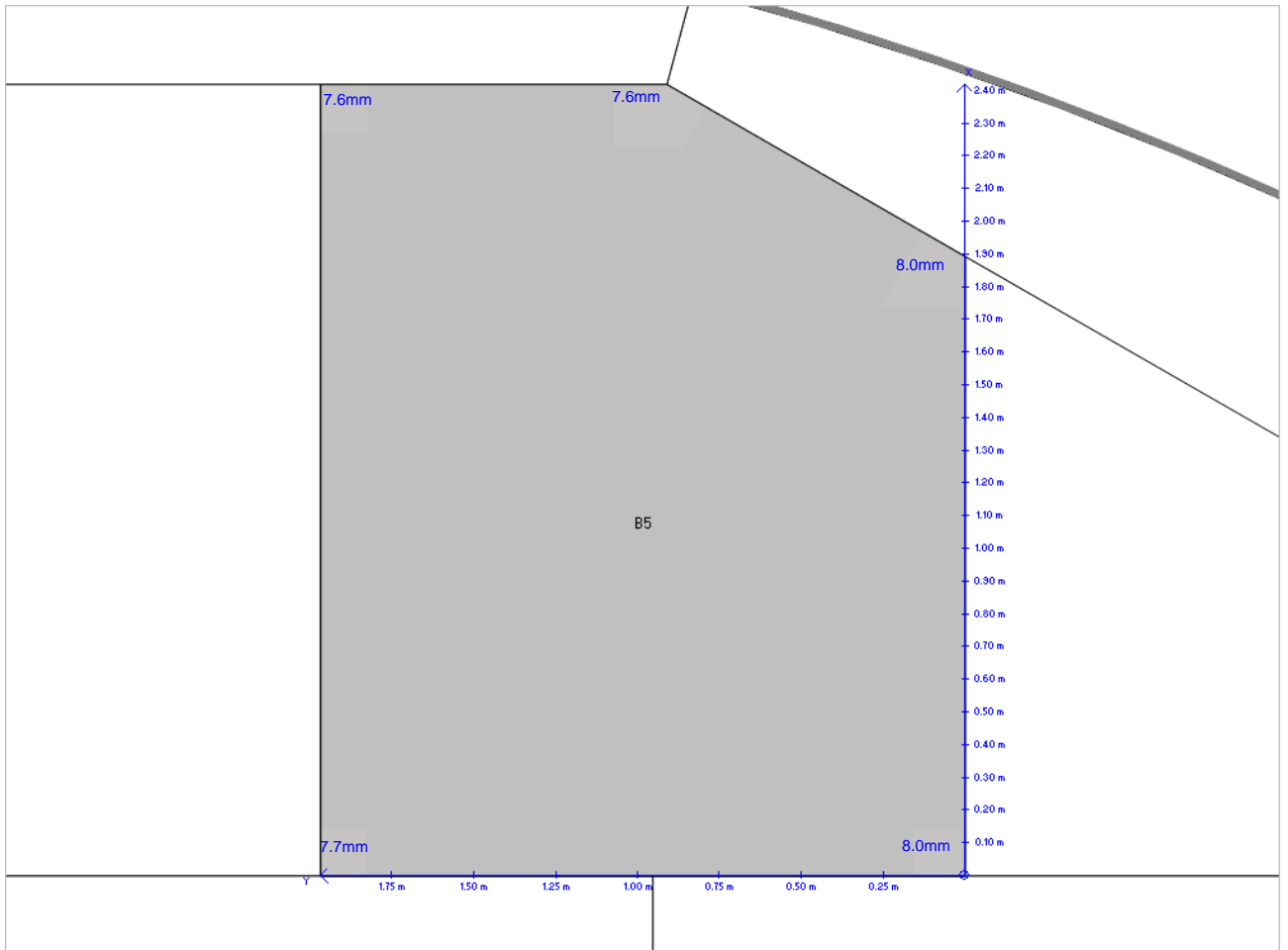

<ul style="list-style-type: none"> : Client a : Site b : 03/05/2016 : B 6 	<ul style="list-style-type: none"> : Tank 123 : K0xx-16 : Jxx86
---	--

Ultrasonic Thickness Readings

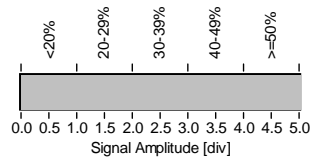
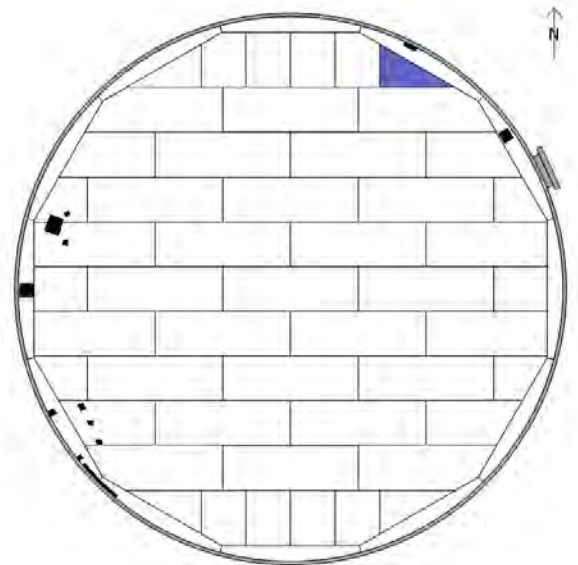
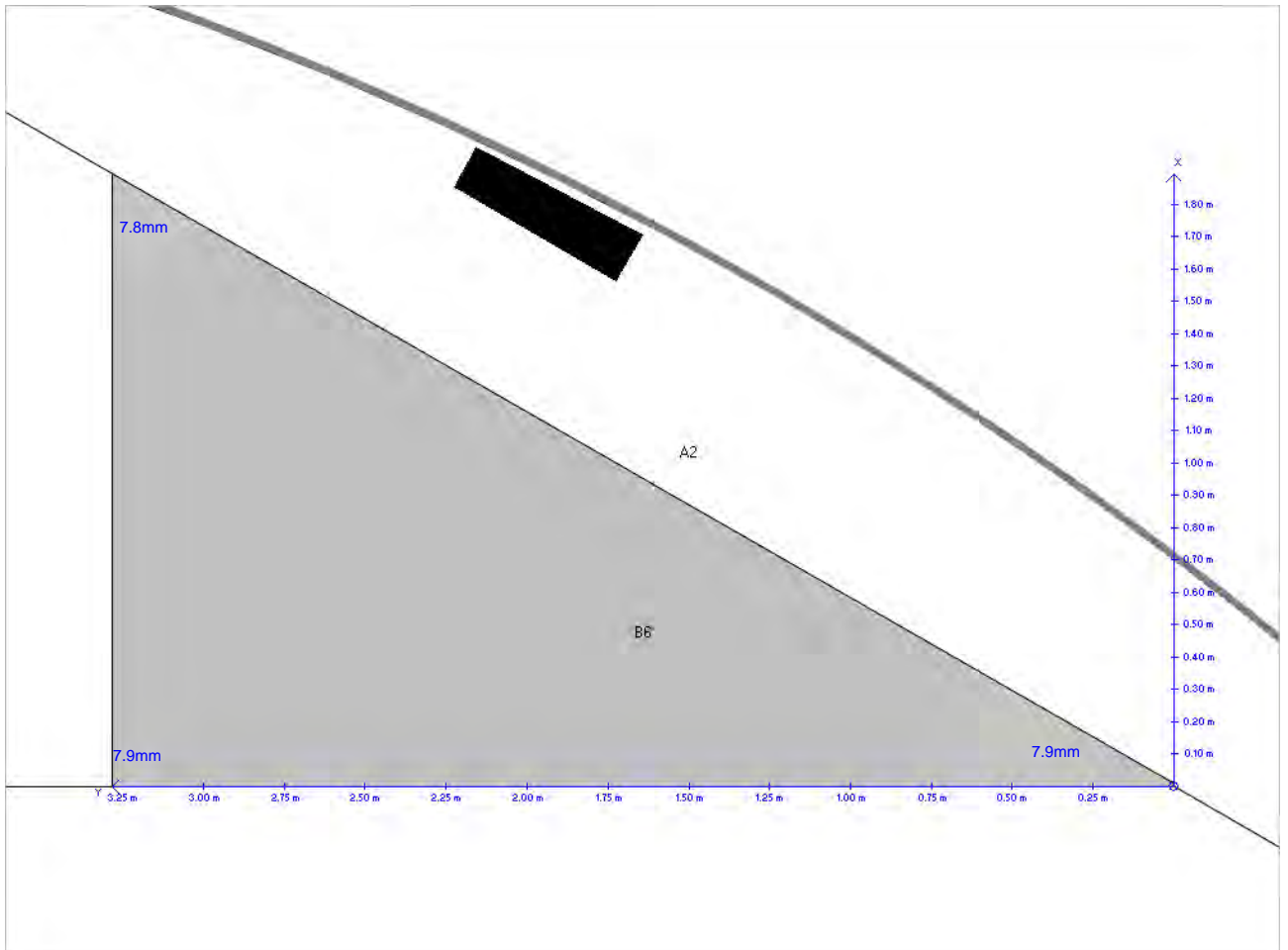

: Client a : Site b : 03/05/2016 : B 7	: Tank 123 : K0xx-16 : Jxx86
---	------------------------------------

Ultrasonic Thickness Readings

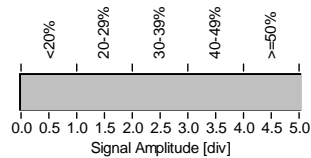
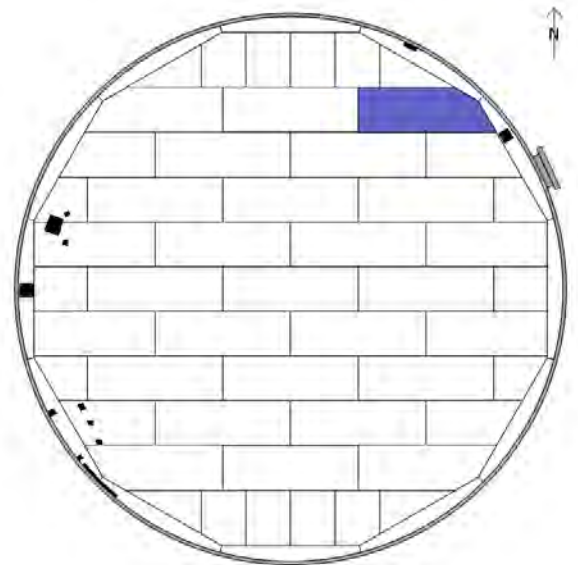
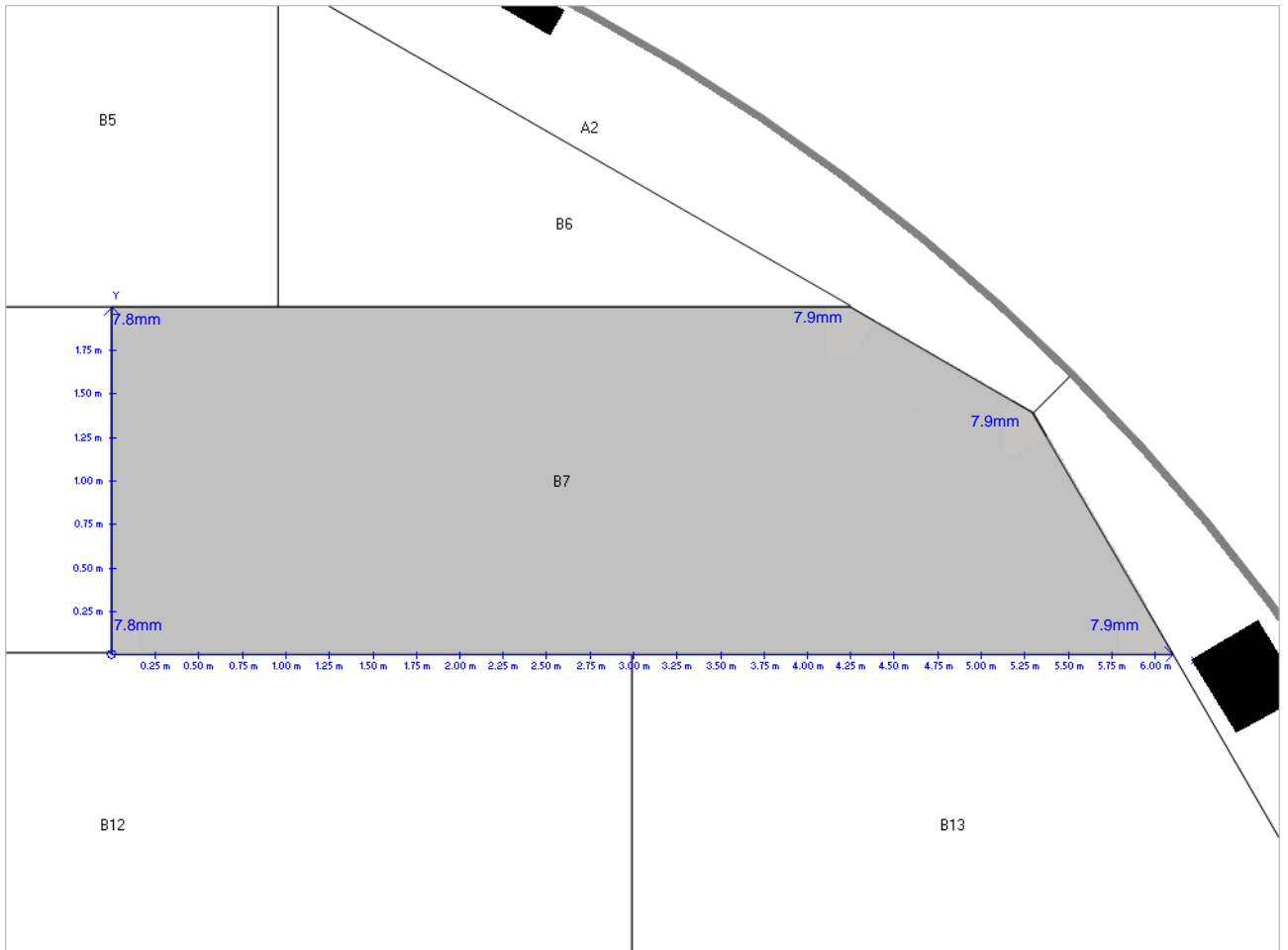

: Client x : Site b : 03/05/2016 : B 8	: Tank 123 : K0xx-16 : Jxx86
---	------------------------------------

Ultrasonic Thickness Readings

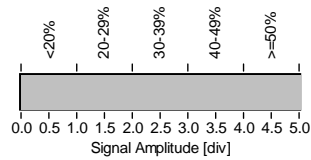
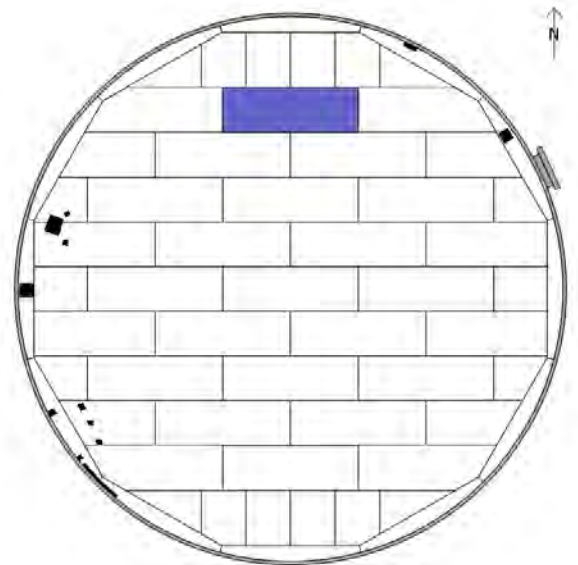
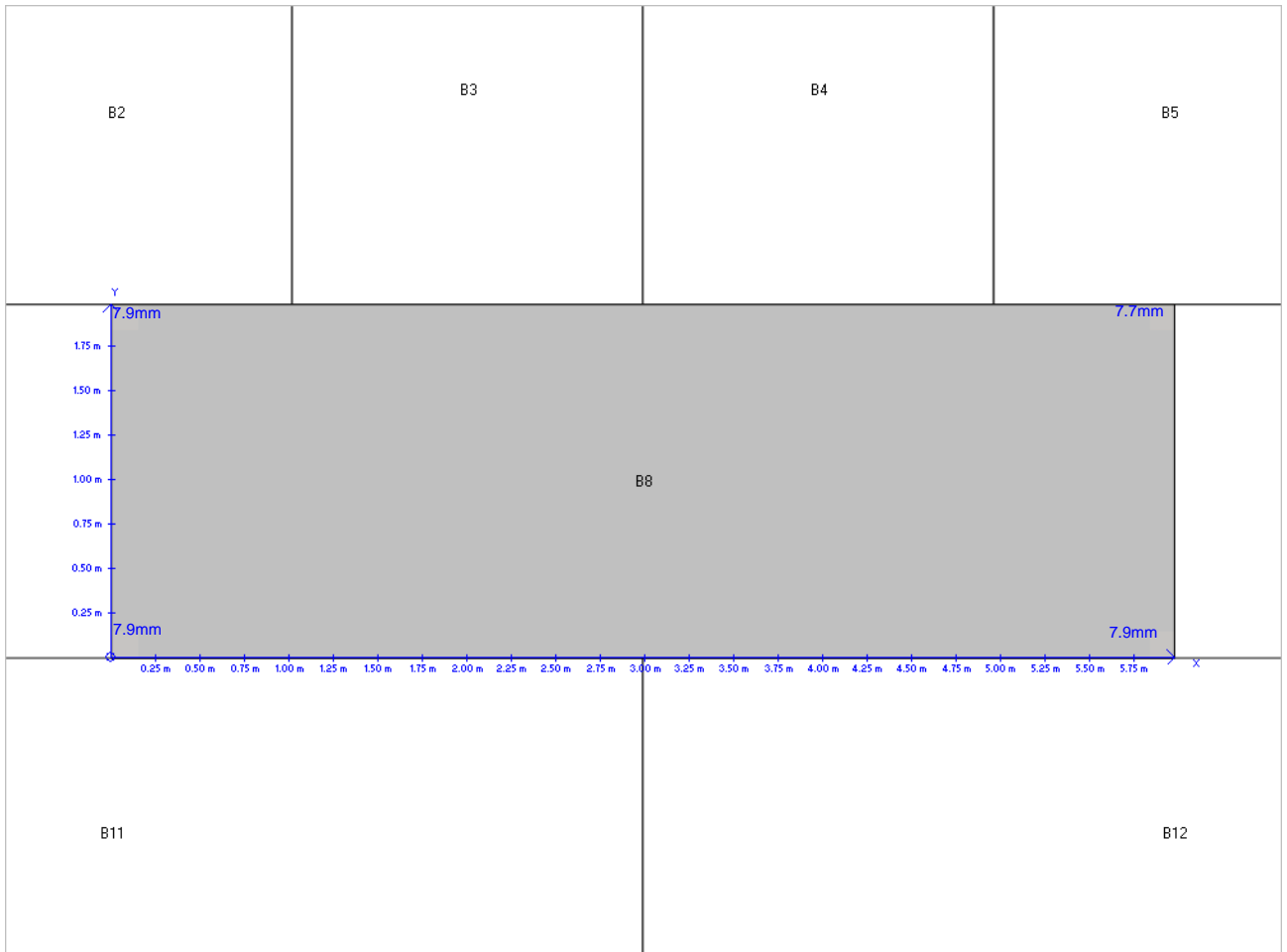

<ul style="list-style-type: none"> : Client a : Site b : 03/05/2016 : B 9 	<ul style="list-style-type: none"> : Tank 123 : K0xx-16 : Jxx86
---	--

Ultrasonic Thickness Readings

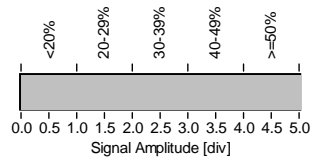
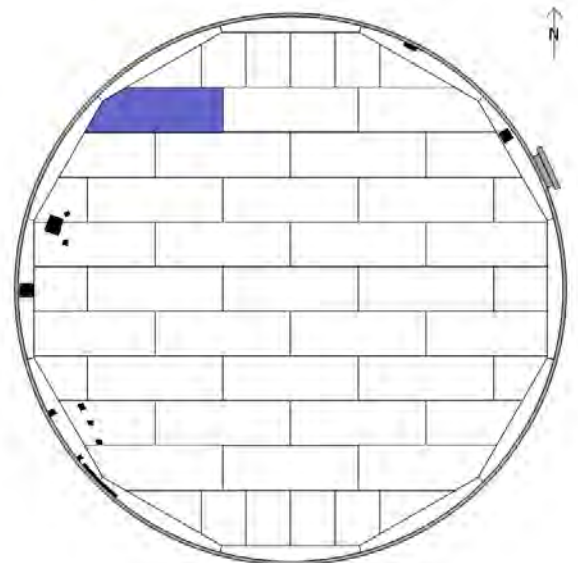
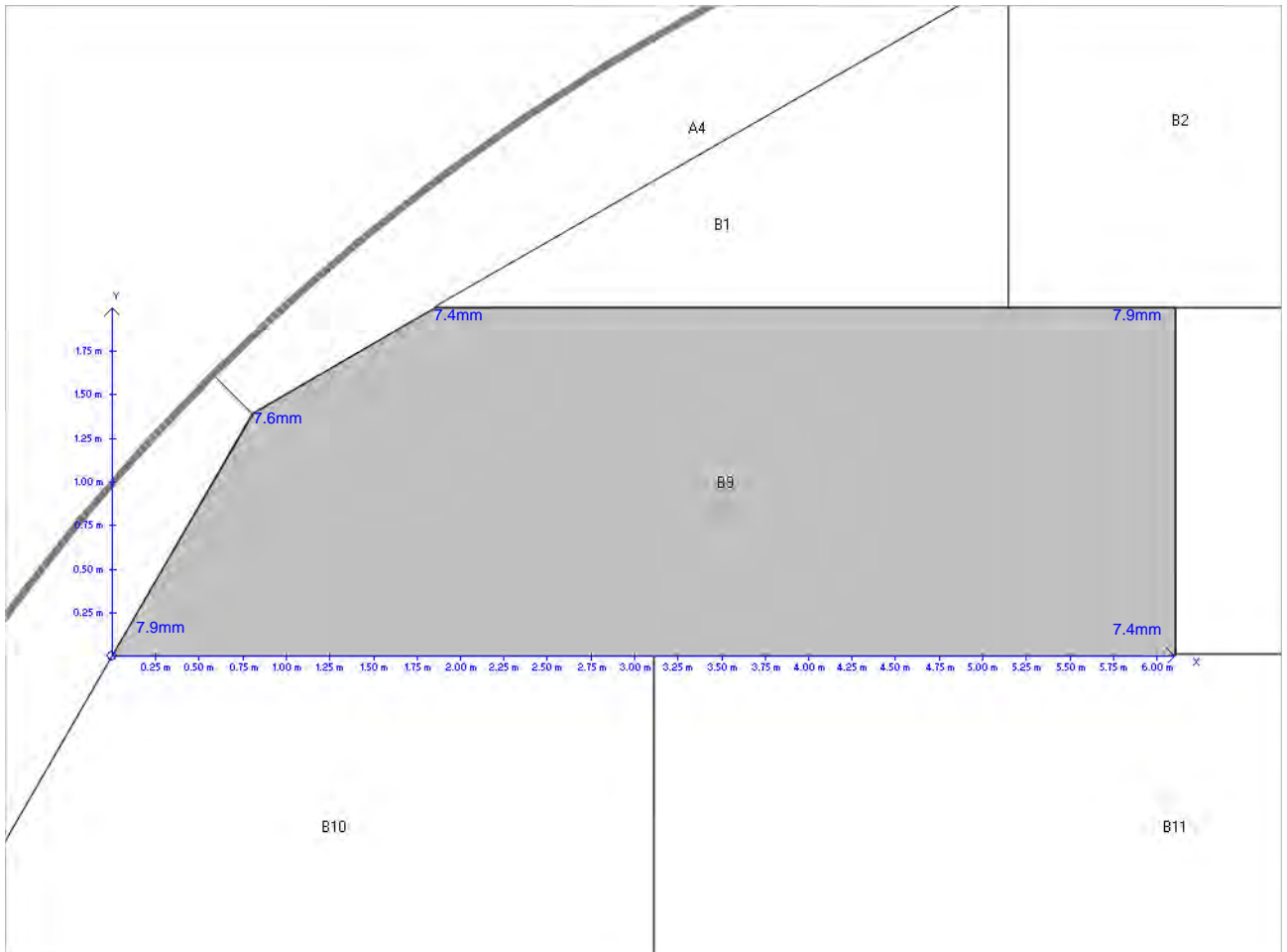

<ul style="list-style-type: none"> : Client a : Site b : 03/05/2016 : B 10 	<ul style="list-style-type: none"> : Tank 123 : K0xx-16 : Jxx86
--	--

Ultrasonic Thickness Readings

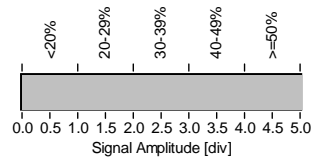
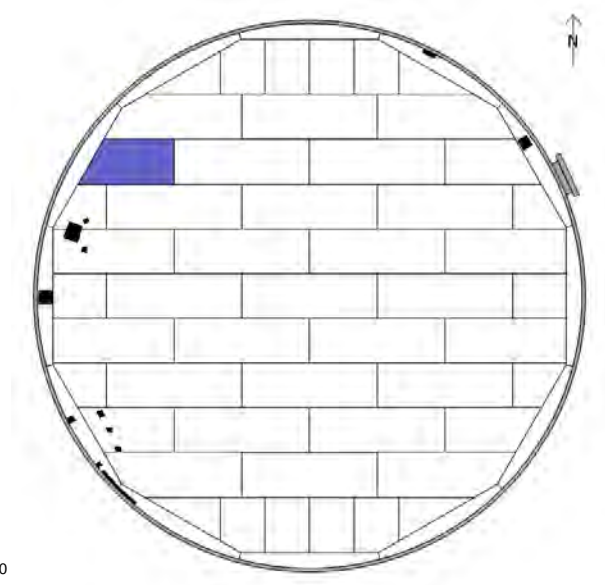
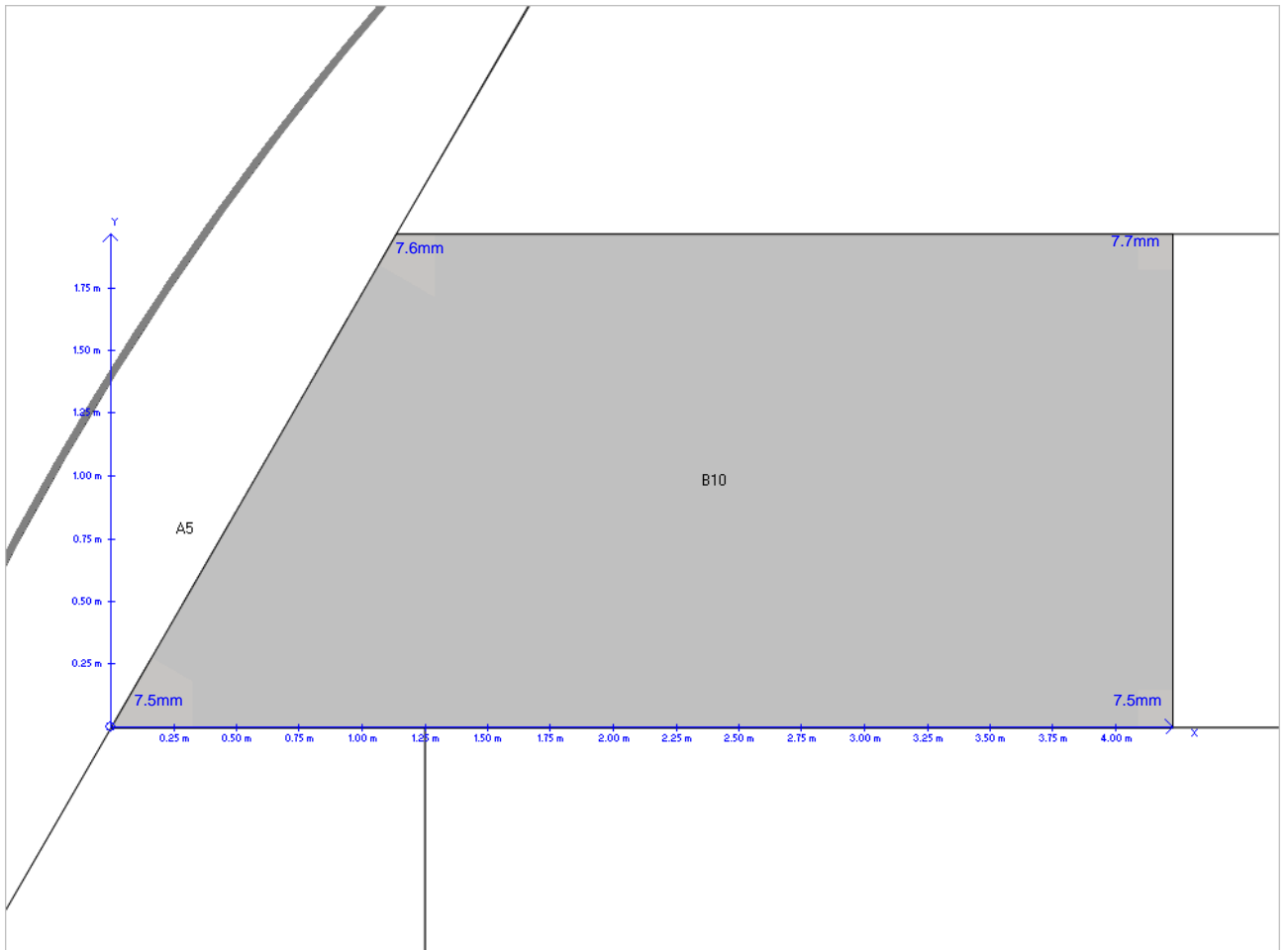

: Client a : Site b : 03/05/2016 : B 11	: Tank 123 : K0xx-16 : Jxx86
--	------------------------------------

Ultrasonic Thickness Readings

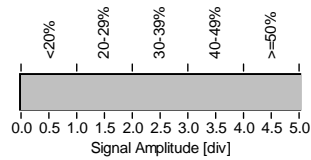
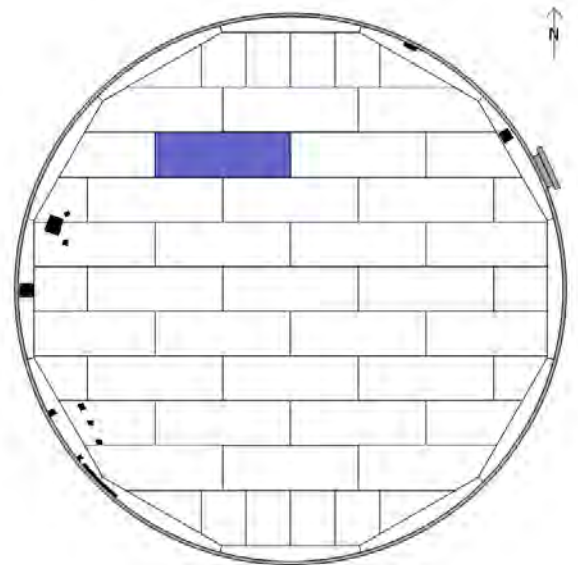
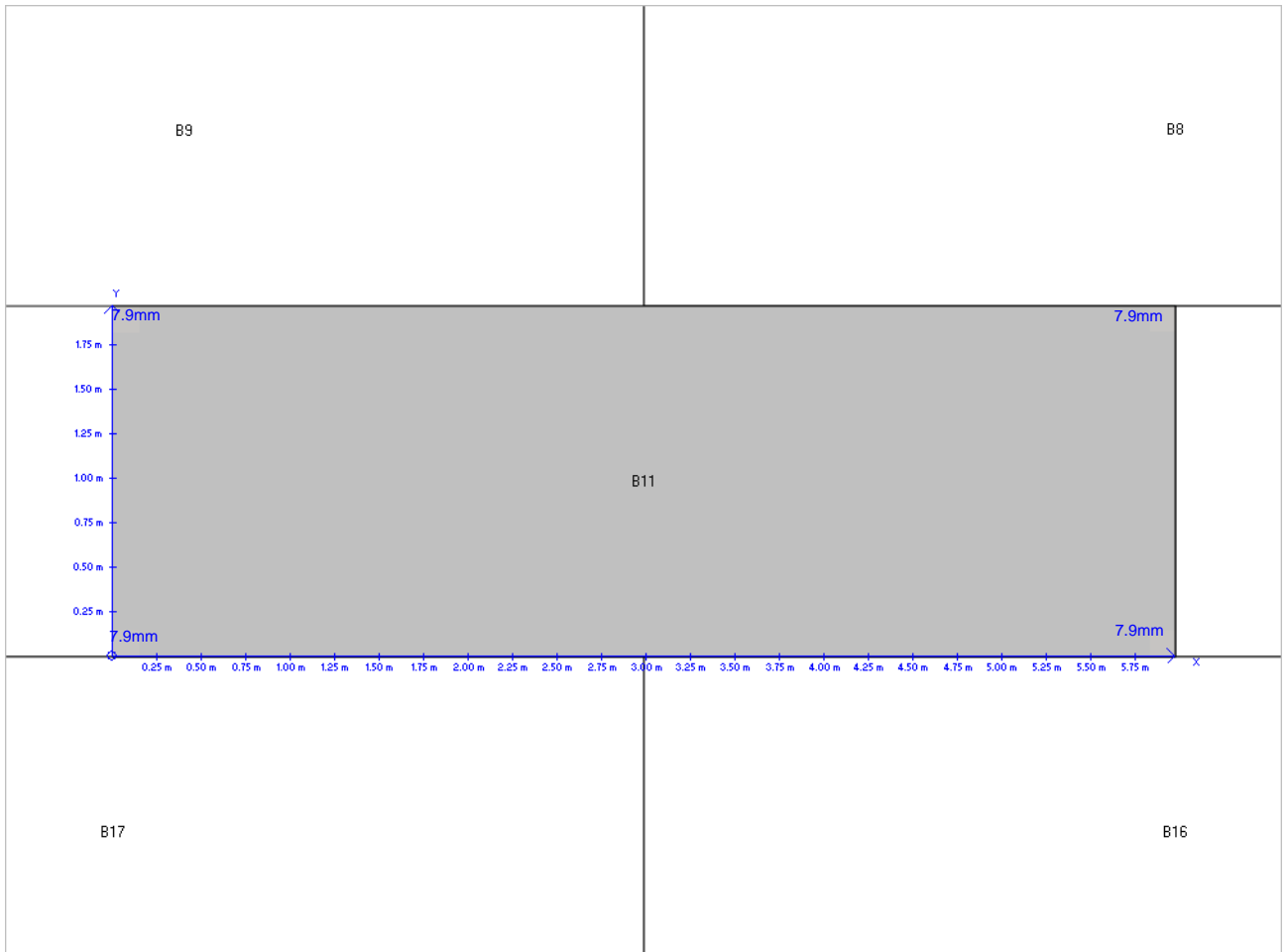

: Client a : Site b : 03/05/2016 : B 12	: Tank 123 : K0xx-16 : Jxx86
--	------------------------------------

Ultrasonic Thickness Readings

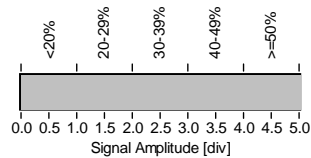
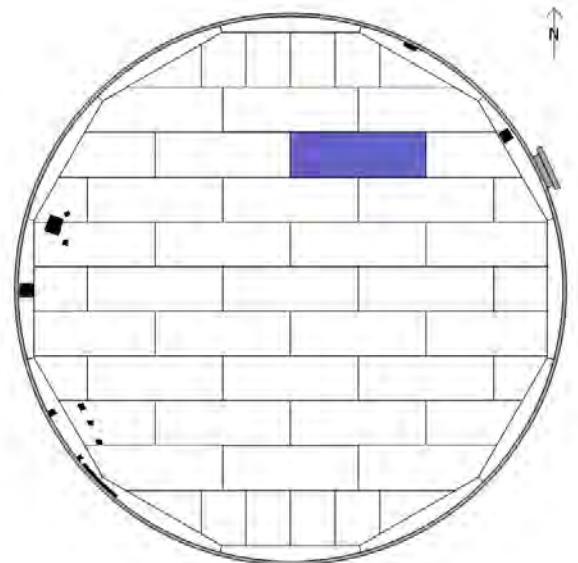
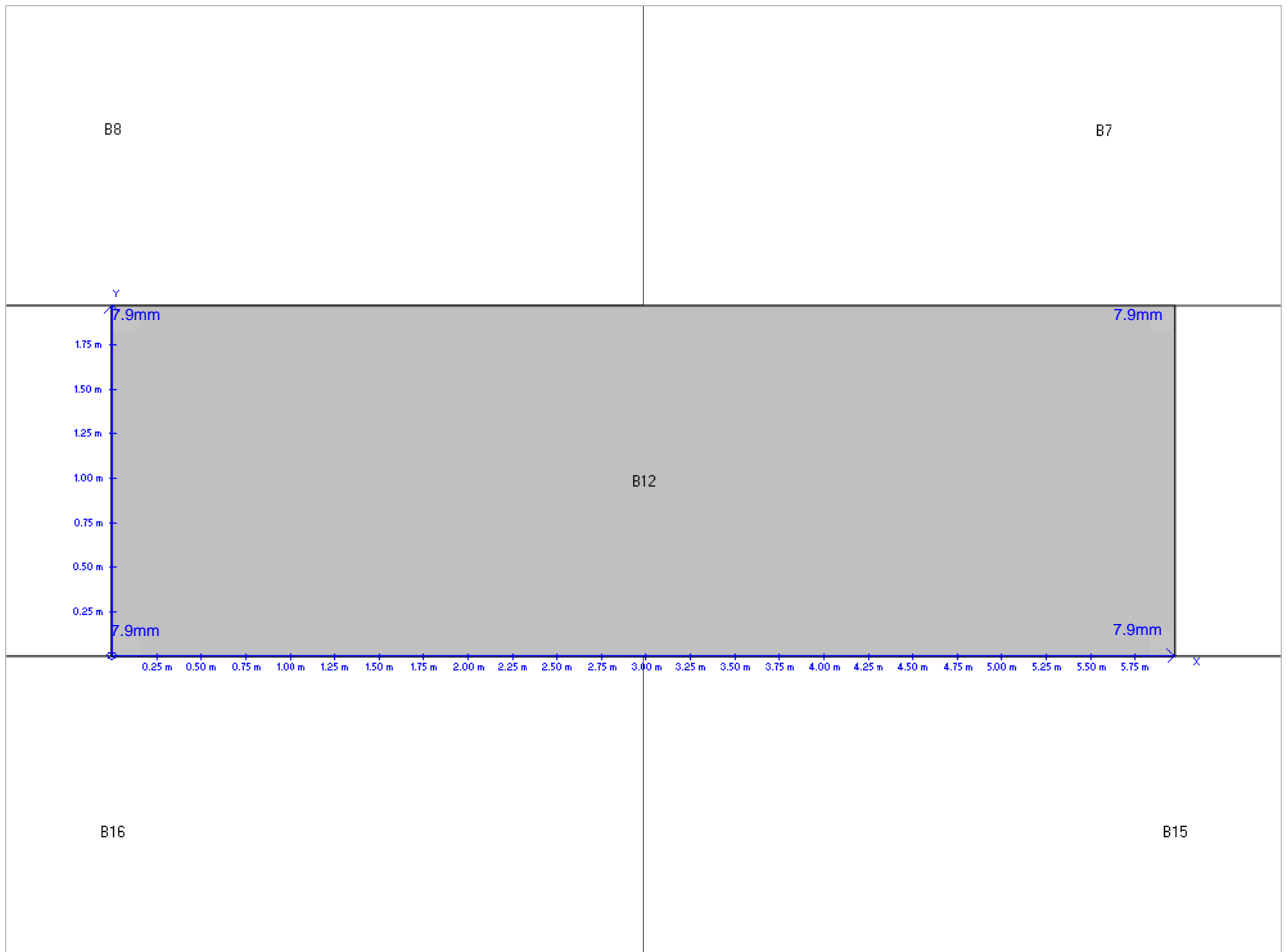

<ul style="list-style-type: none"> : Client a : Site b : 03/05/2016 : B 13 	<ul style="list-style-type: none"> : Tank 123 : K0xx-16 : Jxx86
--	--

Ultrasonic Thickness Readings

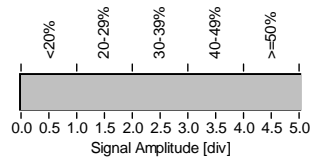
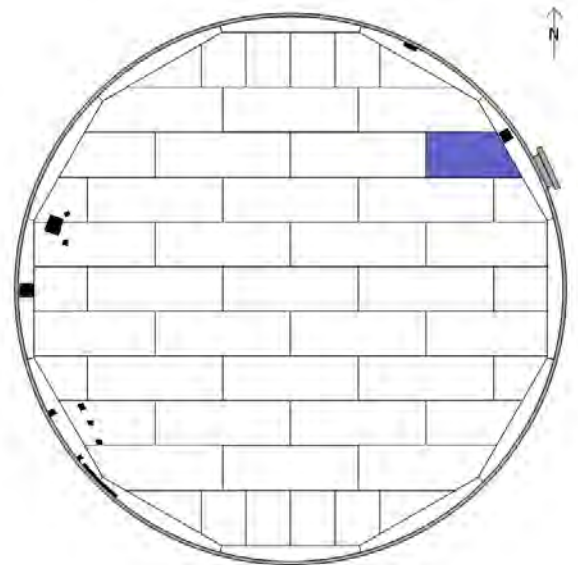
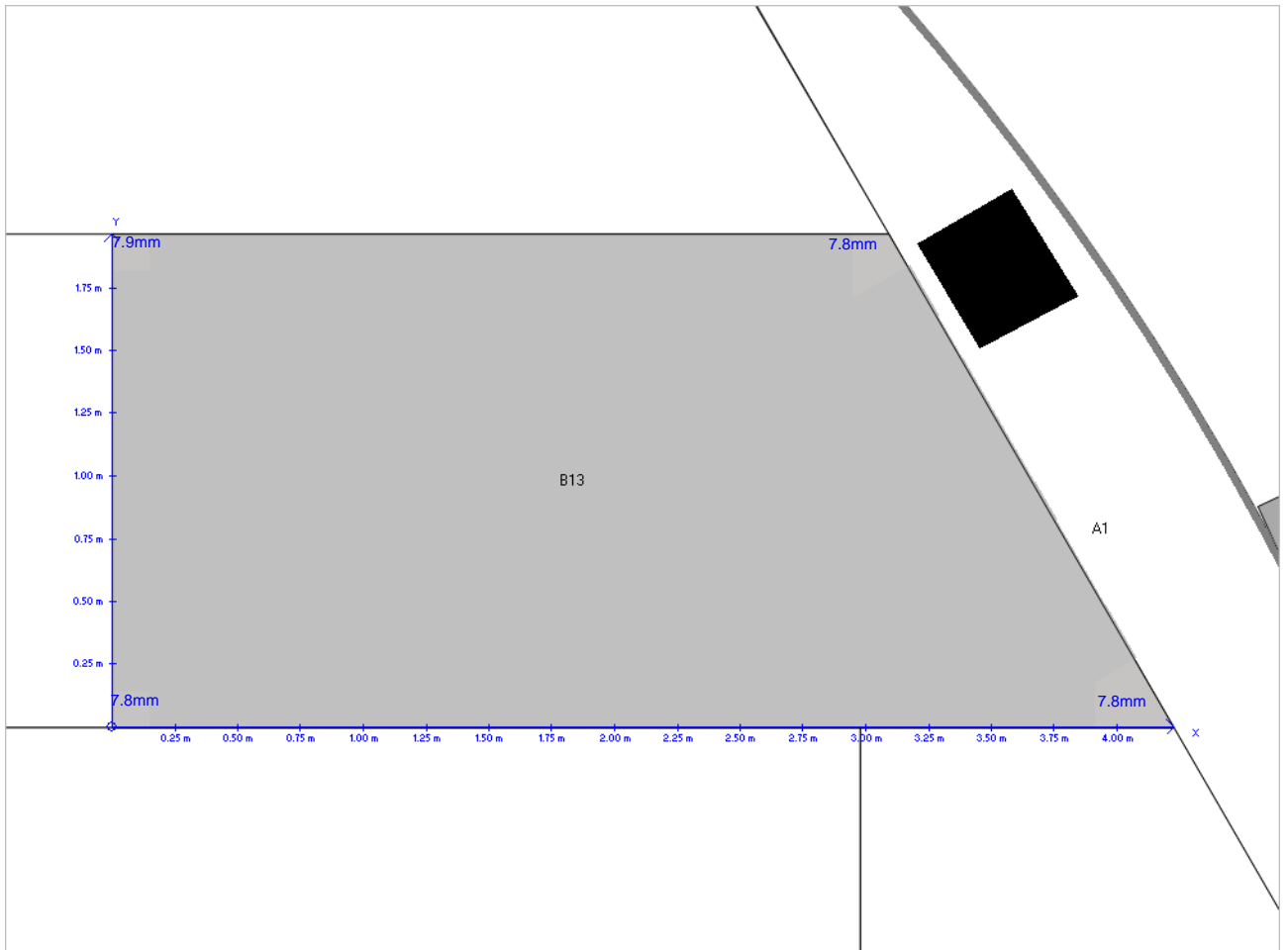

<ul style="list-style-type: none"> : Client a : Site b : 03/05/2016 : B 14 	<ul style="list-style-type: none"> : Tank 123 : K0xx-16 : Jxx86
--	--

Ultrasonic Thickness Readings

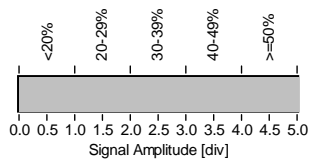
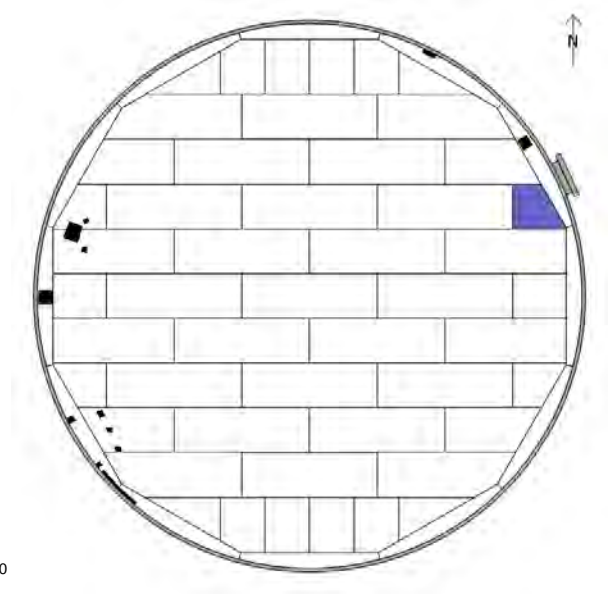
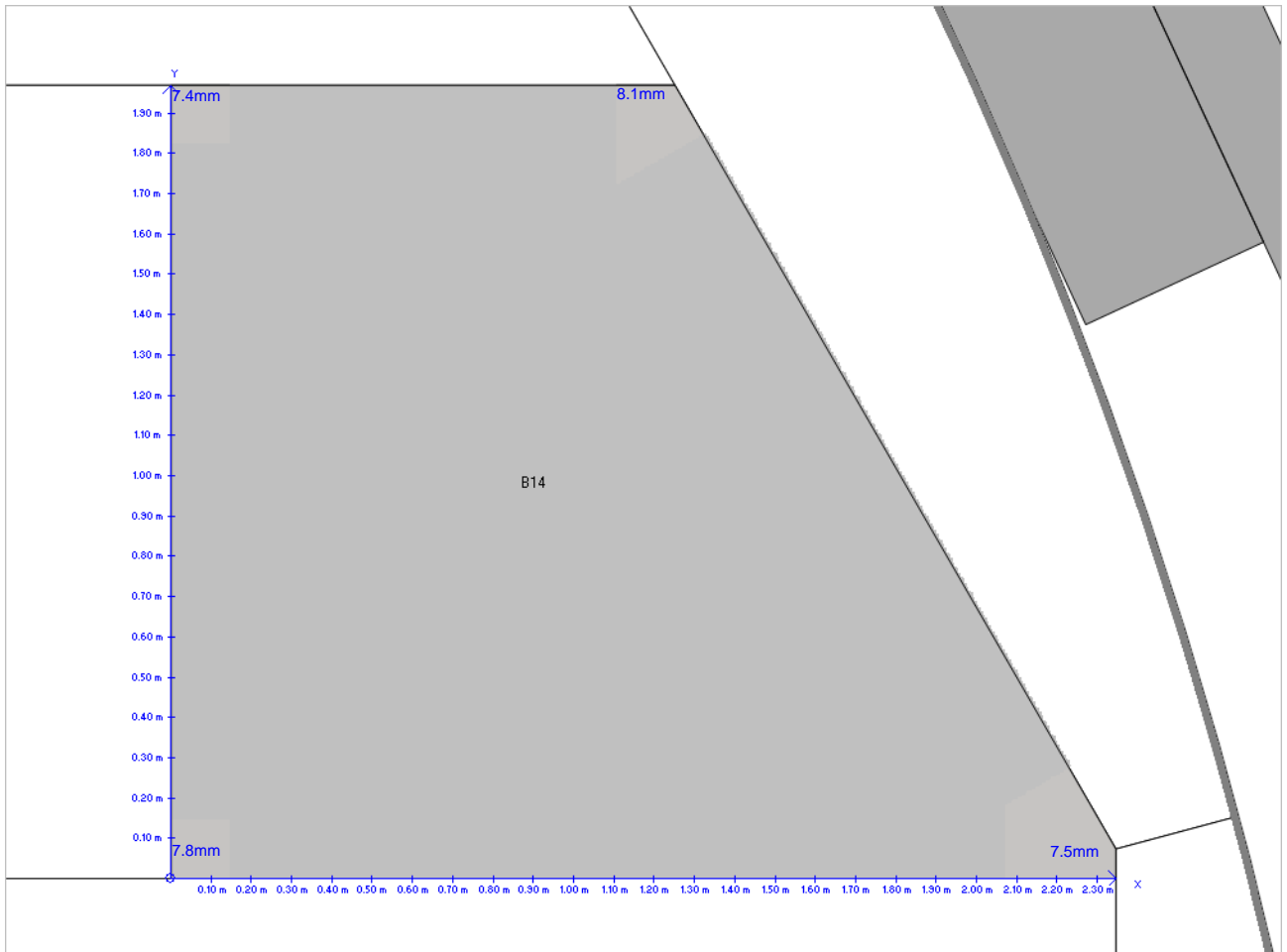

: Client a : Site b : 03/05/2016 : B 15	: Tank 123 : K0xx-16 : Jxx86
--	------------------------------------

Ultrasonic Thickness Readings

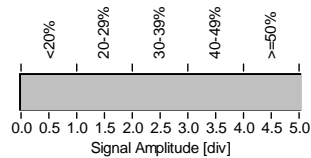
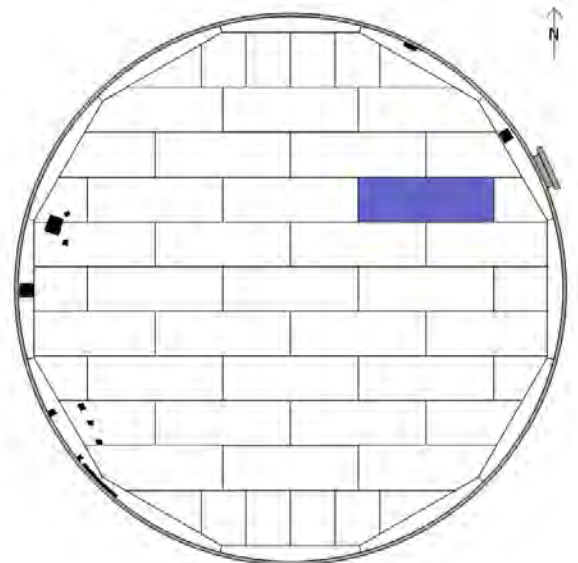
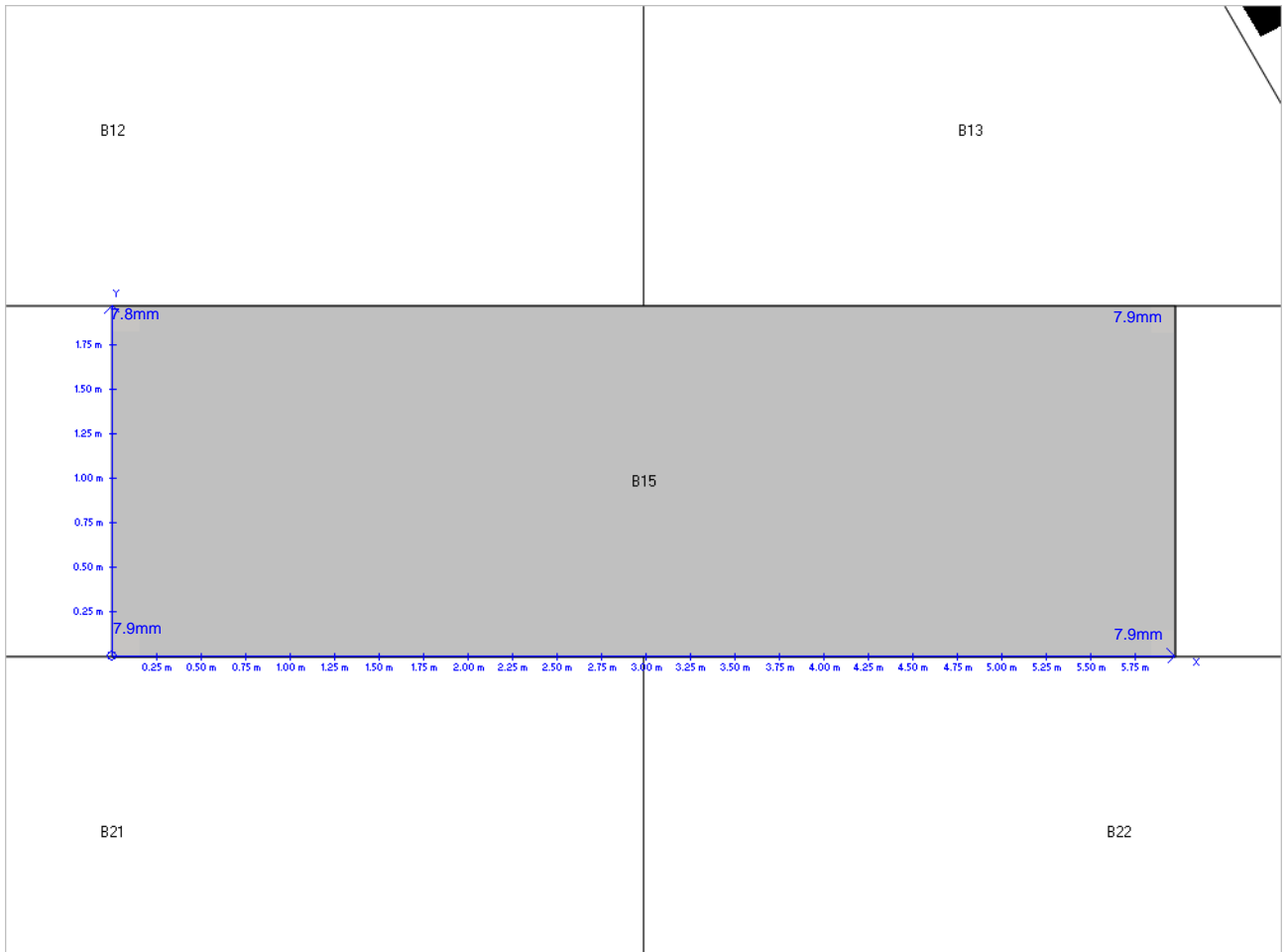

: Client a : Site b : 03/05/2016 : B 16	: Tank 123 : K0xx-16 : Jxx86
--	------------------------------------

Ultrasonic Thickness Readings

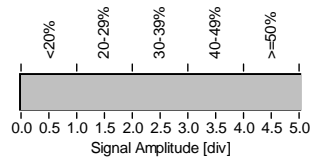
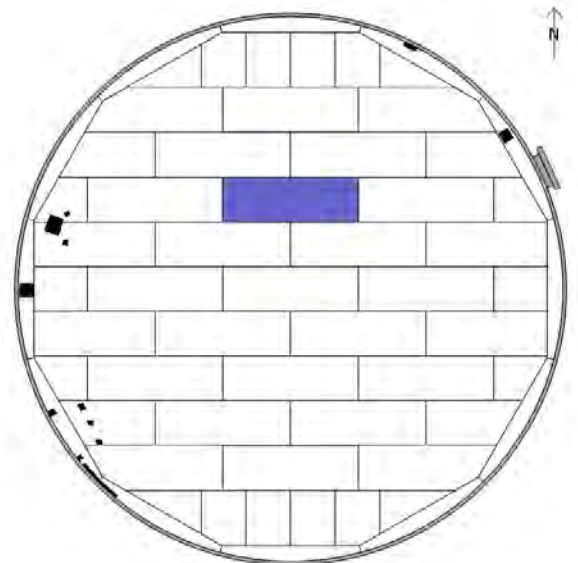
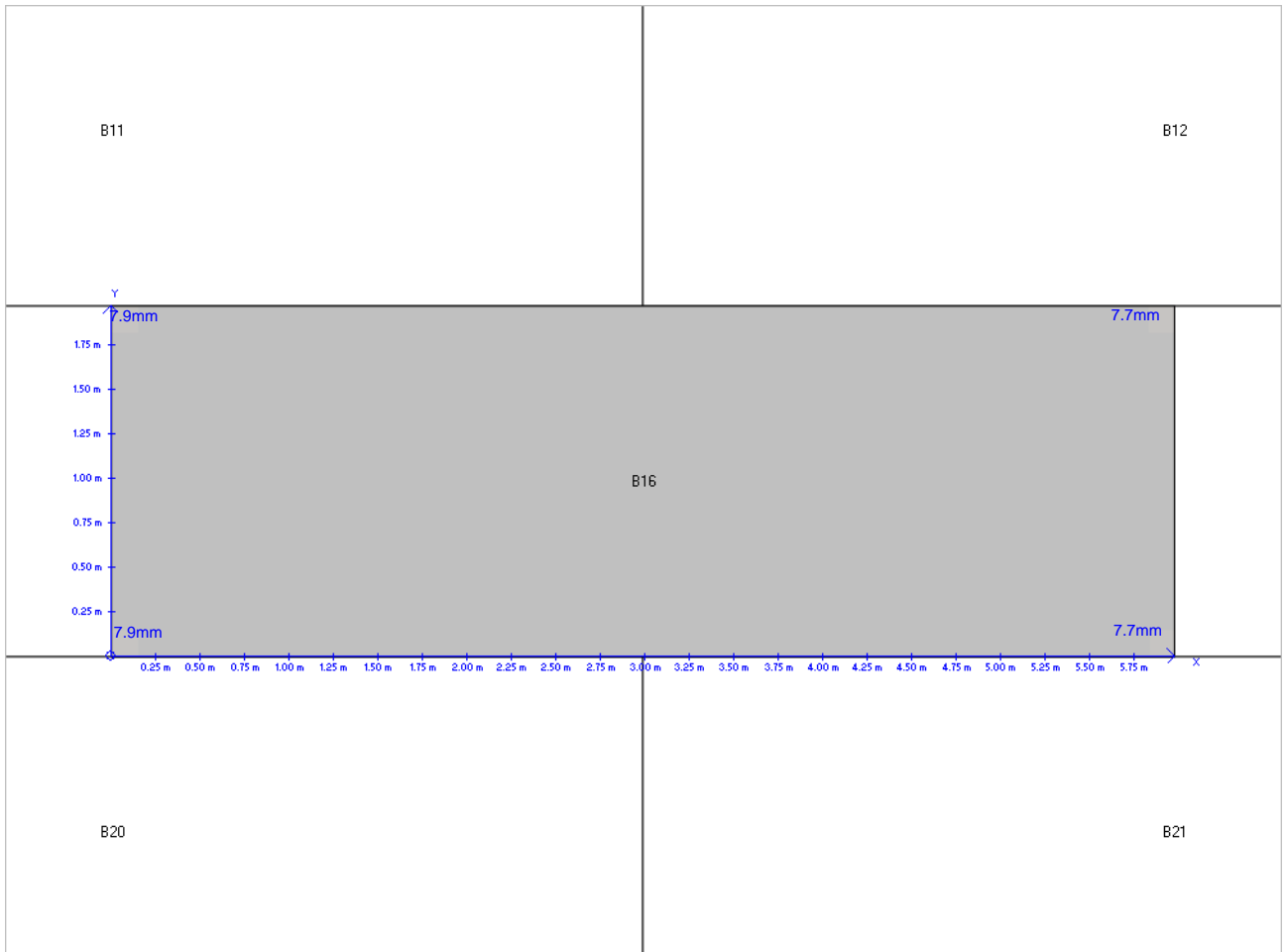

: Client a : Site b : 03/05/2016 : B 17	: Tank 123 : K0xx-16 : Jxx86
--	------------------------------------

Ultrasonic Thickness Readings

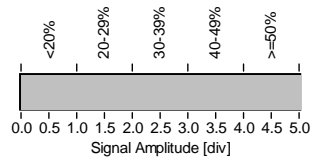
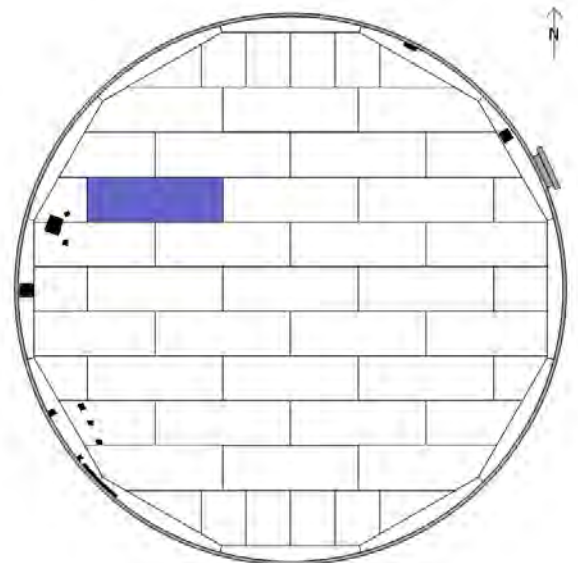

<ul style="list-style-type: none"> : Client a : Site b : 03/05/2016 : B 18 	<ul style="list-style-type: none"> : Tank 123 : K0xx-16 : Jxx86
--	--

Ultrasonic Thickness Readings

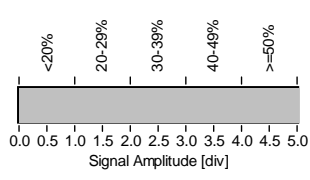
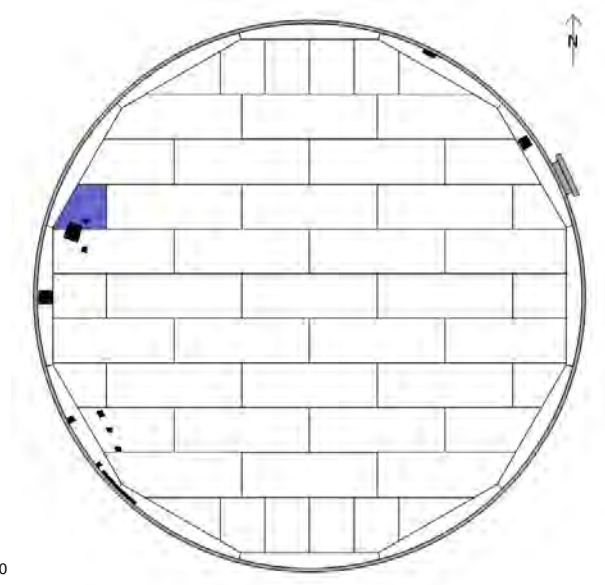
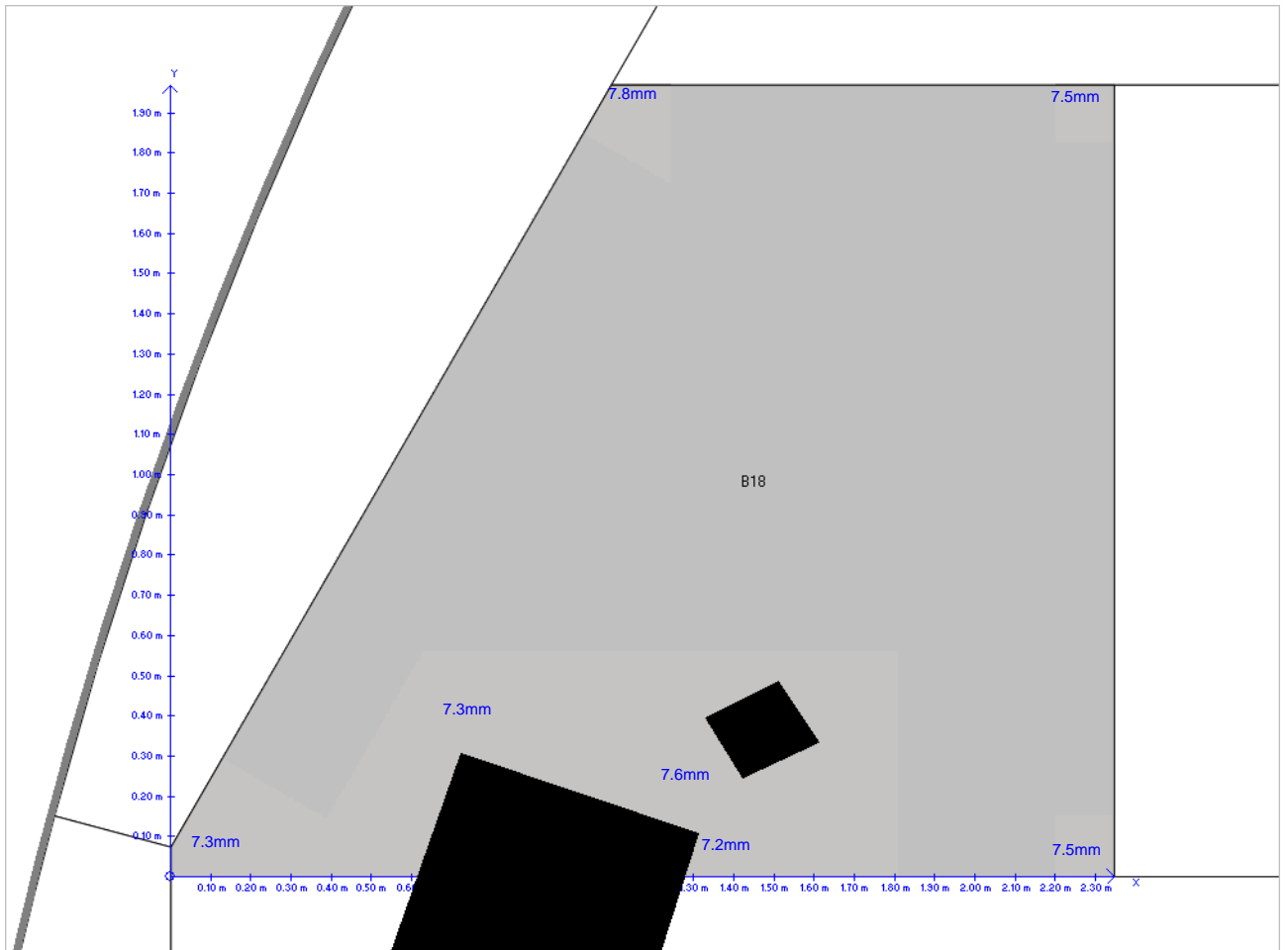

: Client a : Site b : 03/05/2016 : B 19	: Tank 123 : K0xx-16 : Jxx86
--	------------------------------------

Ultrasonic Thickness Readings

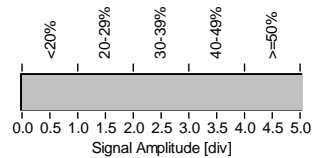
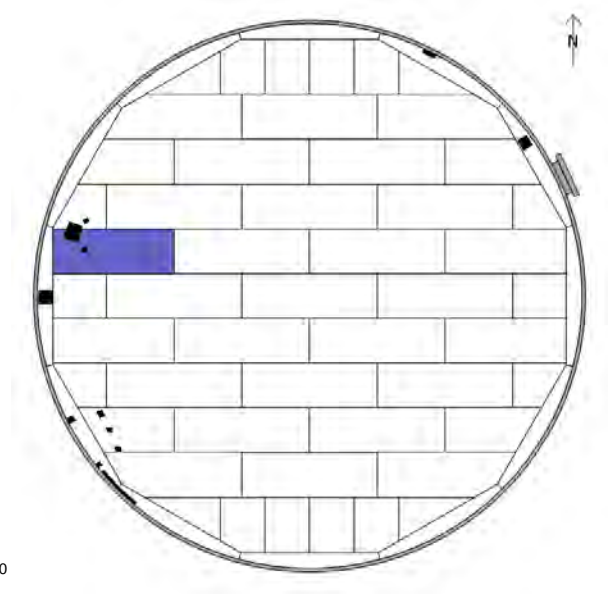
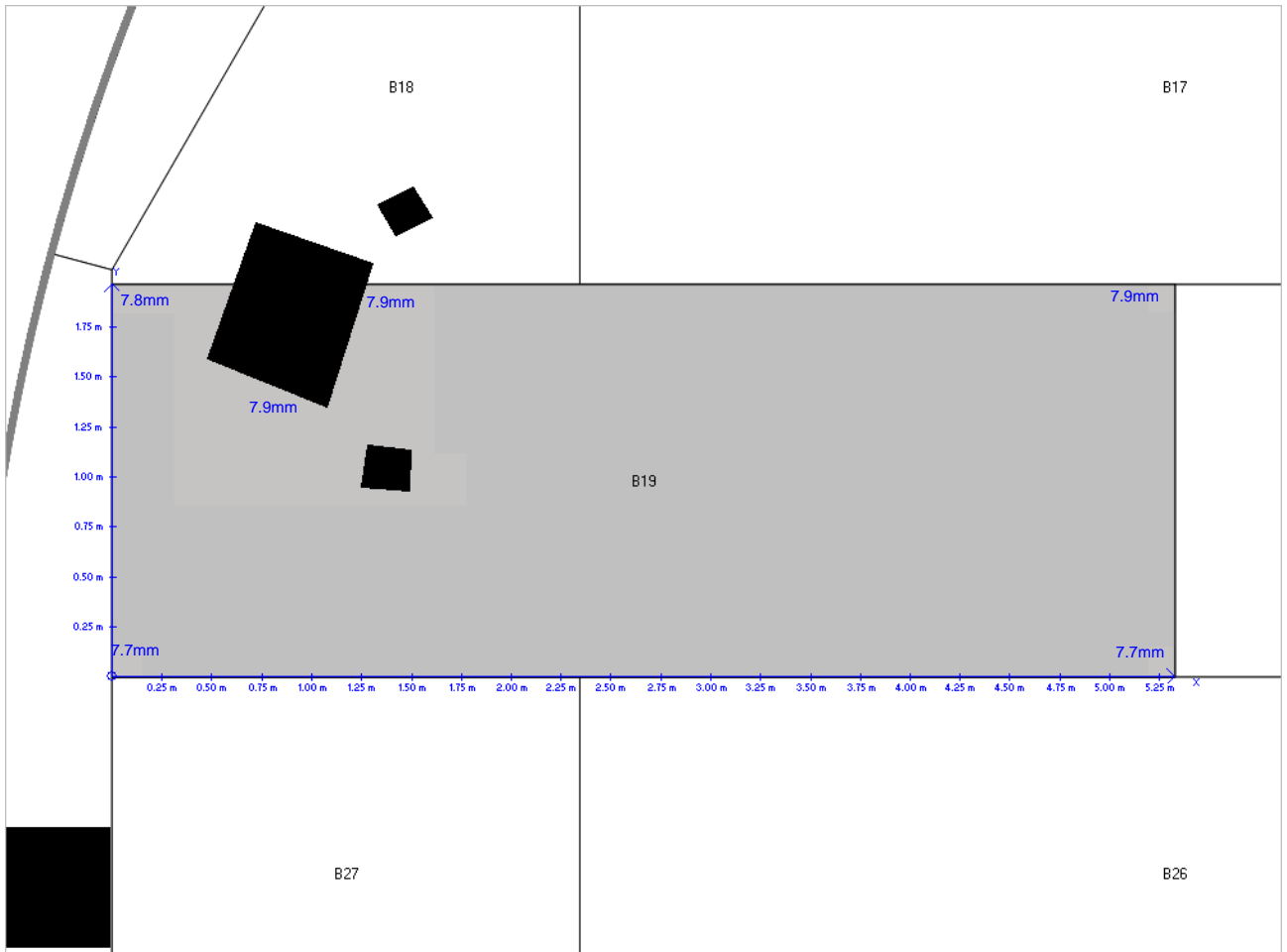

<ul style="list-style-type: none"> : Client a : Site b : 03/05/2016 : B 20 	<ul style="list-style-type: none"> : Tank 123 : K0xx-16 : Jxx86
--	--

Ultrasonic Thickness Readings

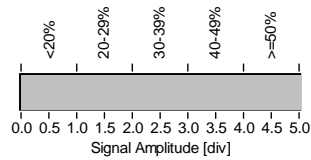
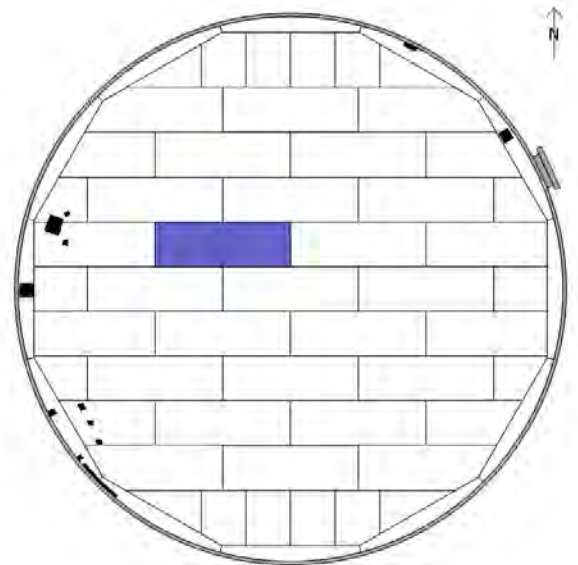
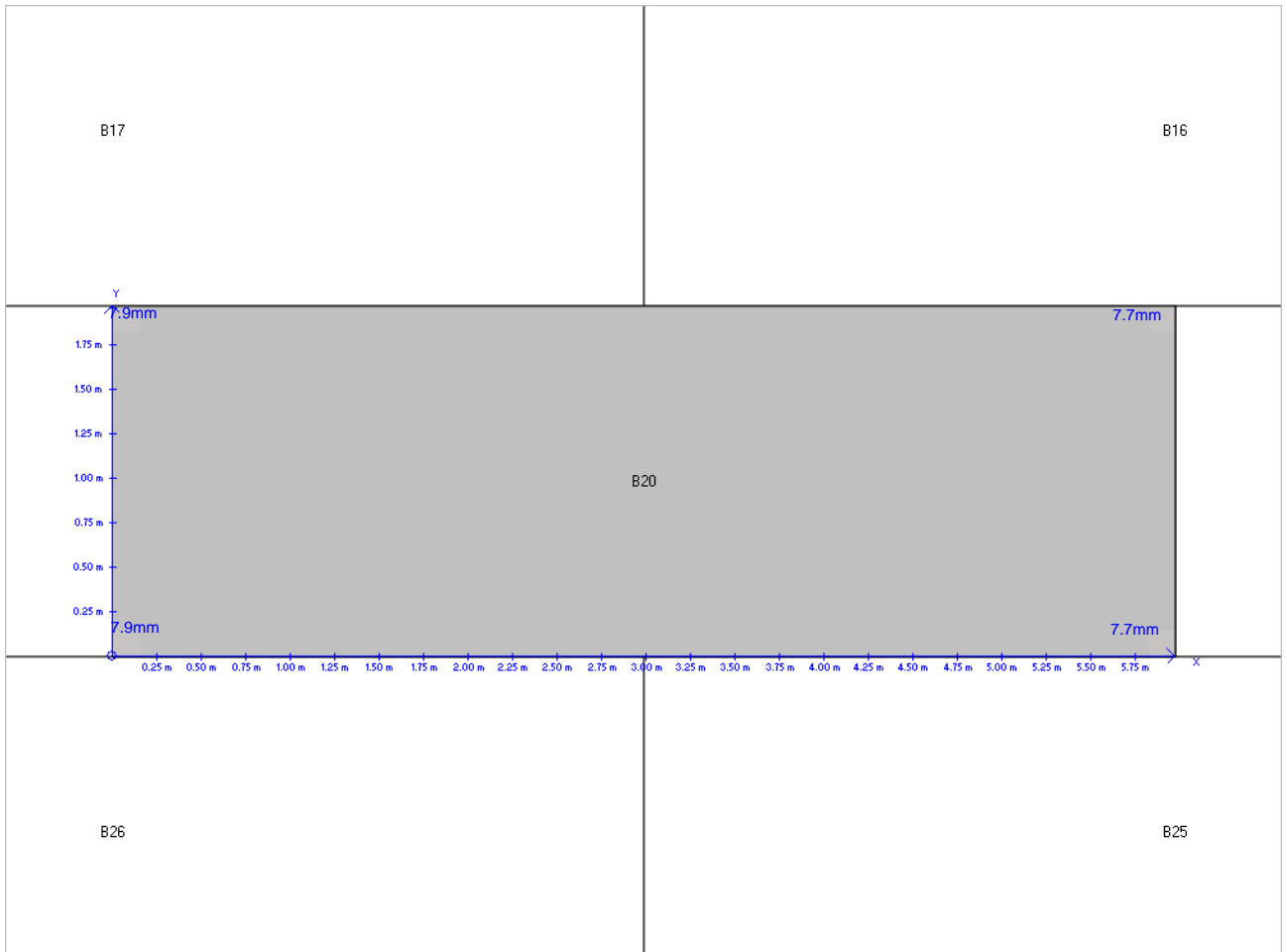

: Client a : Site b : 03/05/2016 : B 21	: Tank 123 : K0xx-16 : Jxx86
--	------------------------------------

Ultrasonic Thickness Readings

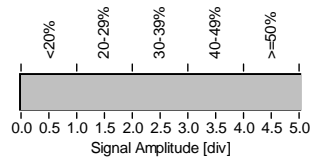
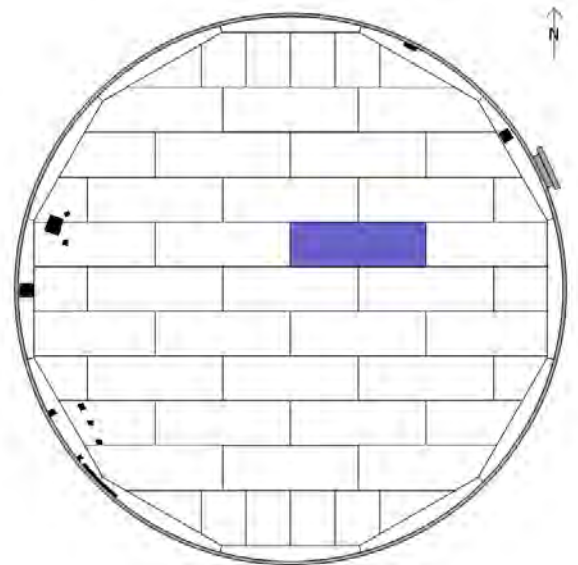
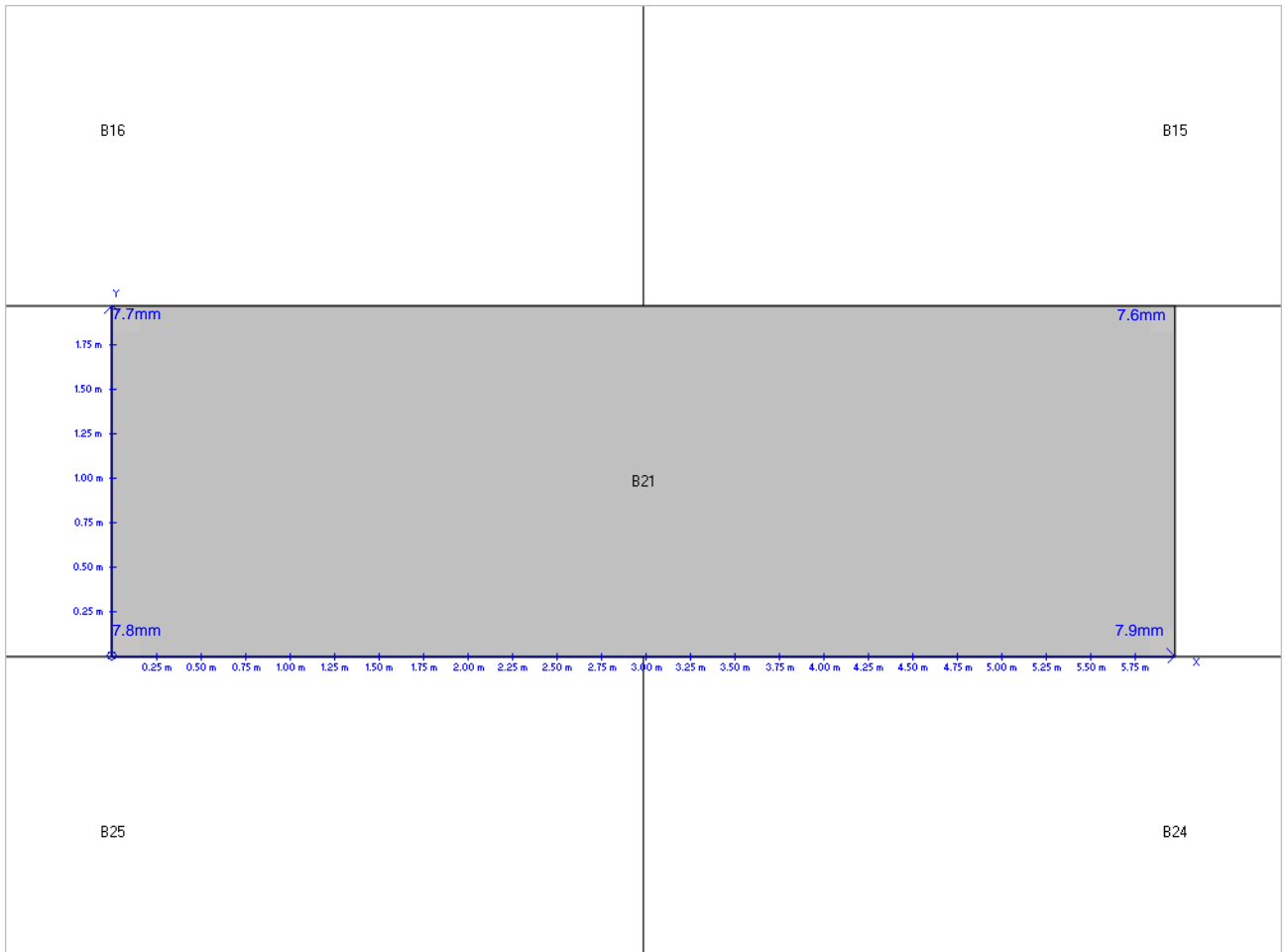

: Client a : Site b : 03/05/2016 : B 22	: Tank 123 : K0xx-16 : Jxx86
--	------------------------------------

Ultrasonic Thickness Readings

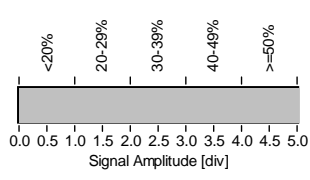
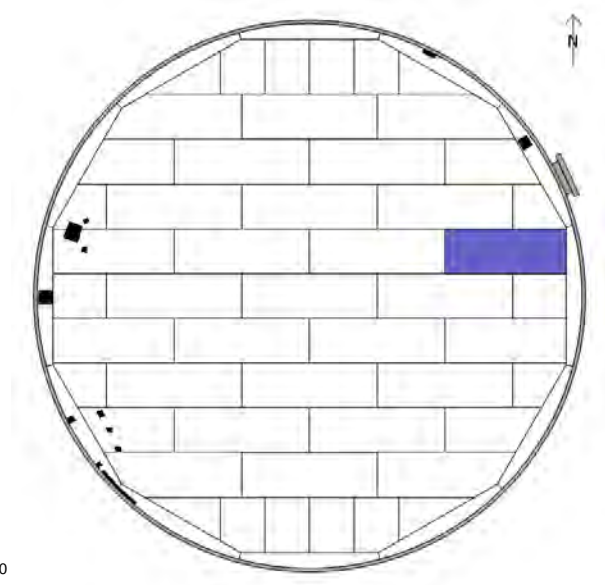
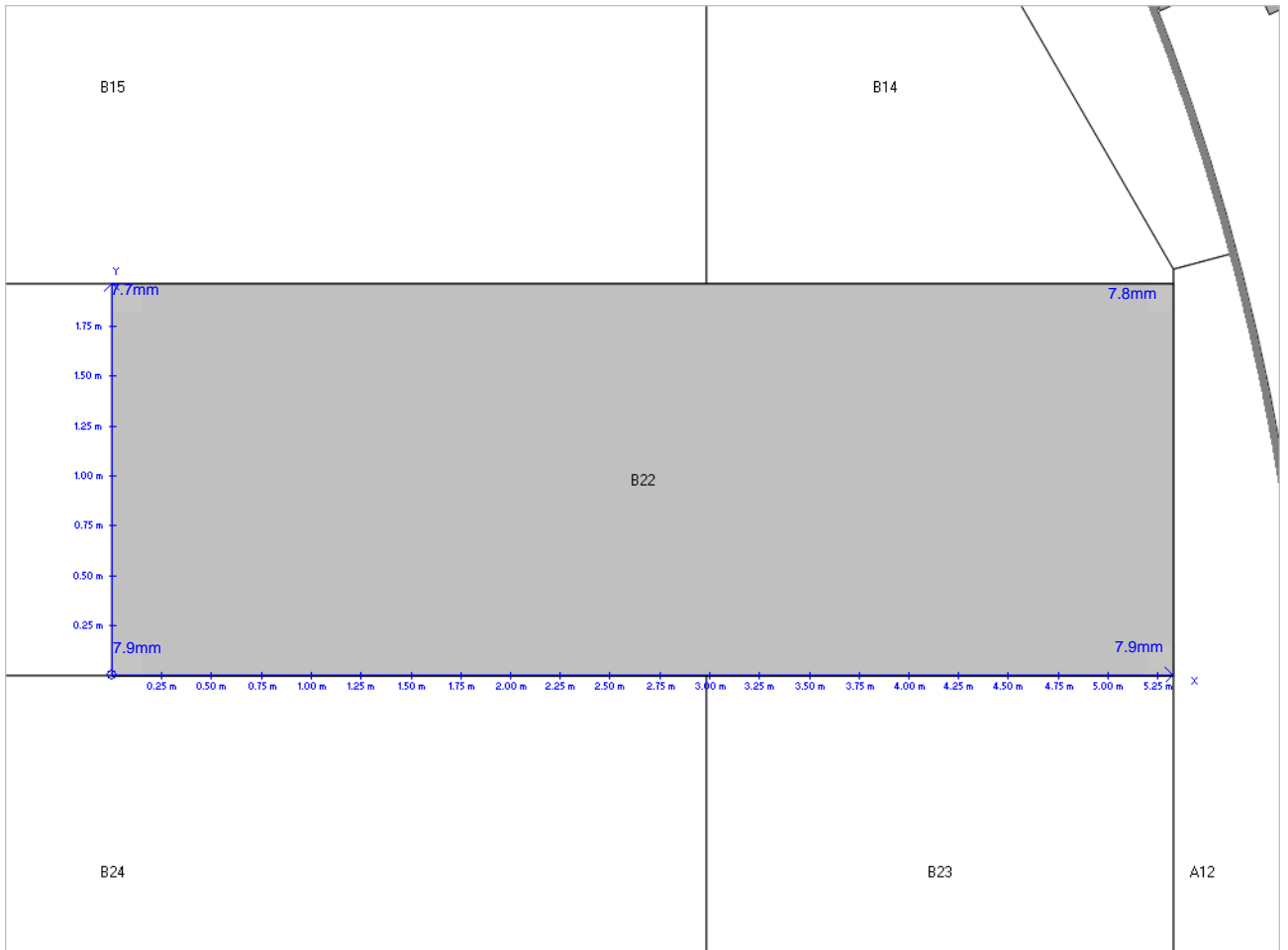

<ul style="list-style-type: none"> : Client a : Site b : 03/05/2016 : B 23 	<ul style="list-style-type: none"> : Tank 123 : K0xx-16 : Jxx86
--	--

Ultrasonic Thickness Readings

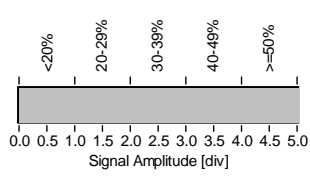
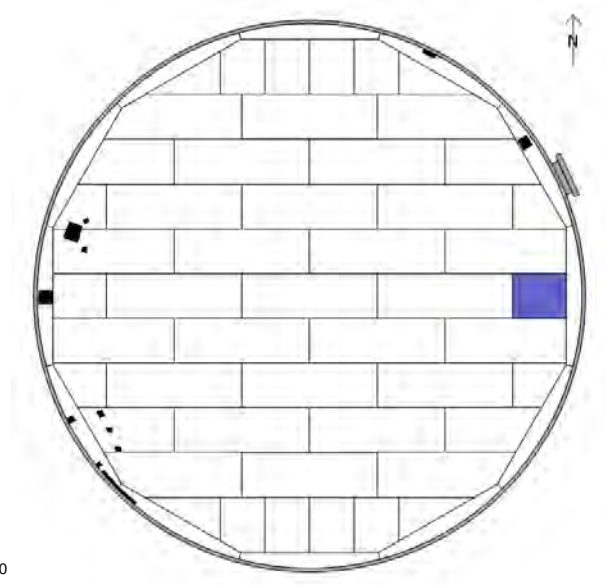
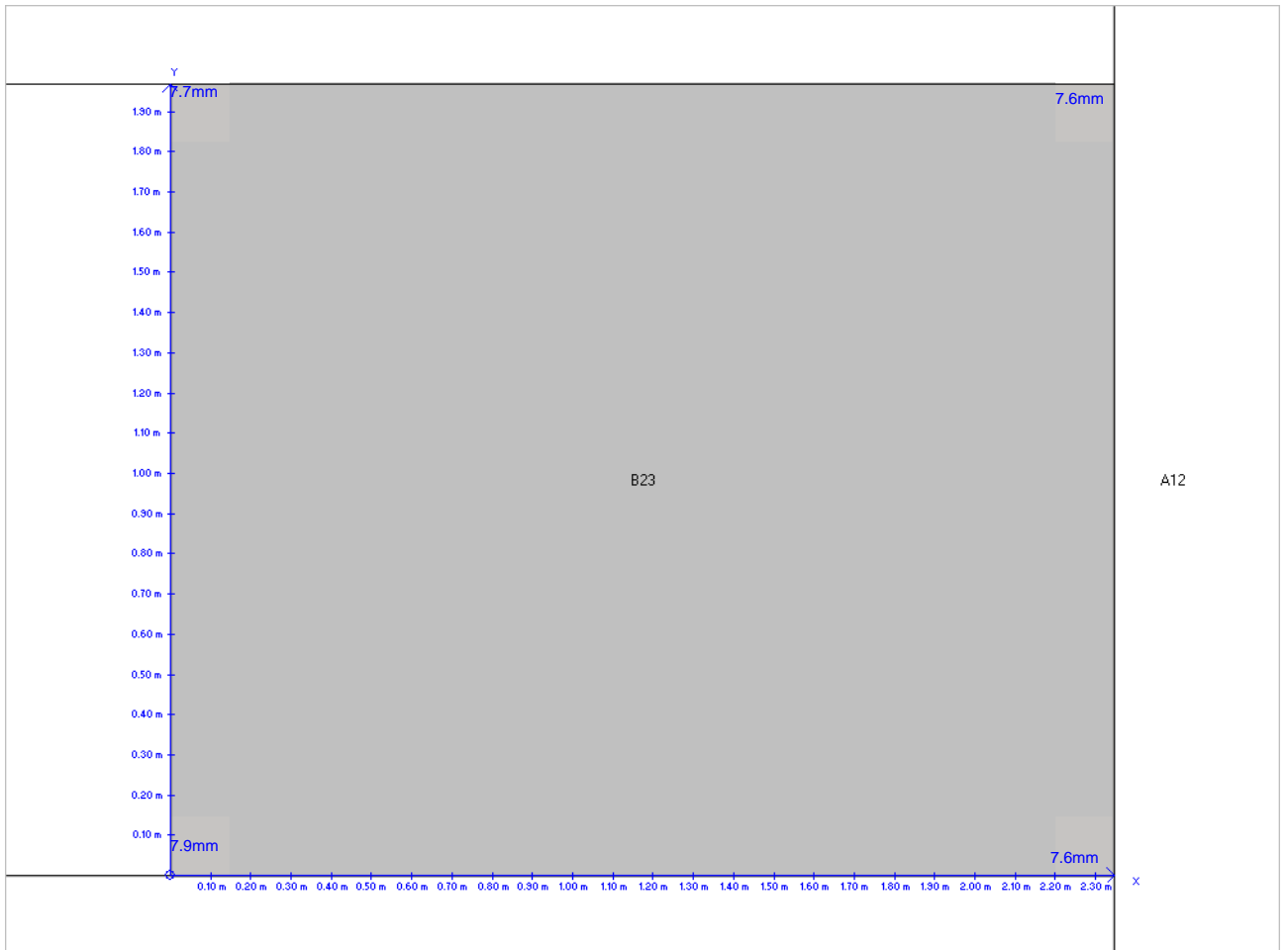

: Client a : Site b : 03/05/2016 : B 24	: Tank 123 : K0xx-16 : Jxx86
--	------------------------------------

Ultrasonic Thickness Readings

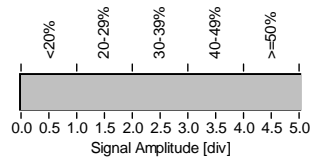
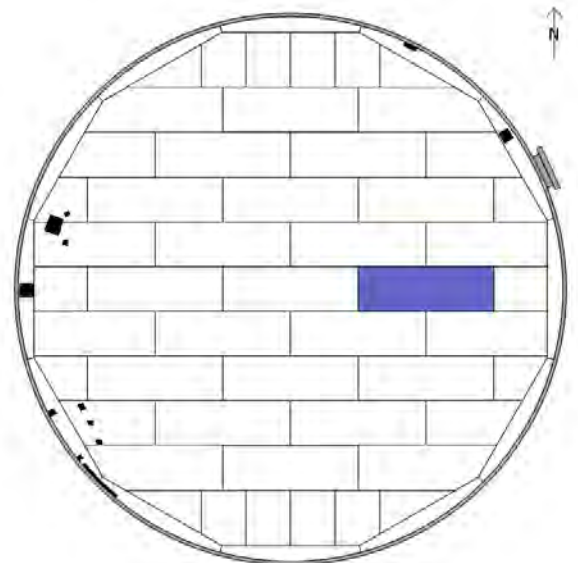
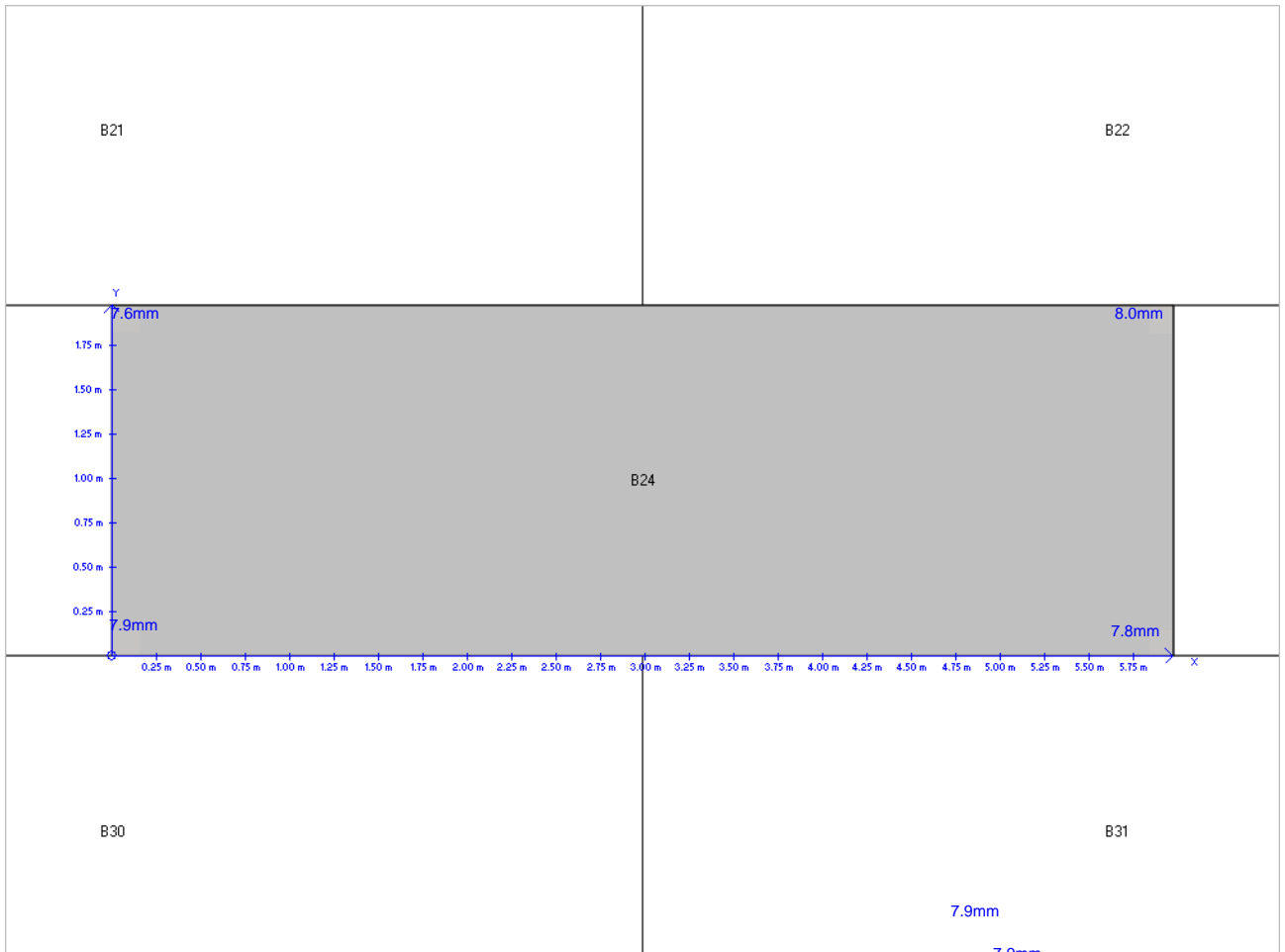

: Client a : Site b : 03/05/2016 : B 25	: Tank 123 : K0xx-16 : Jxx86
--	------------------------------------

Ultrasonic Thickness Readings

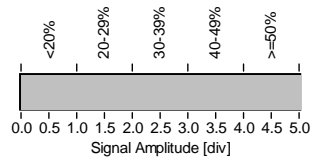
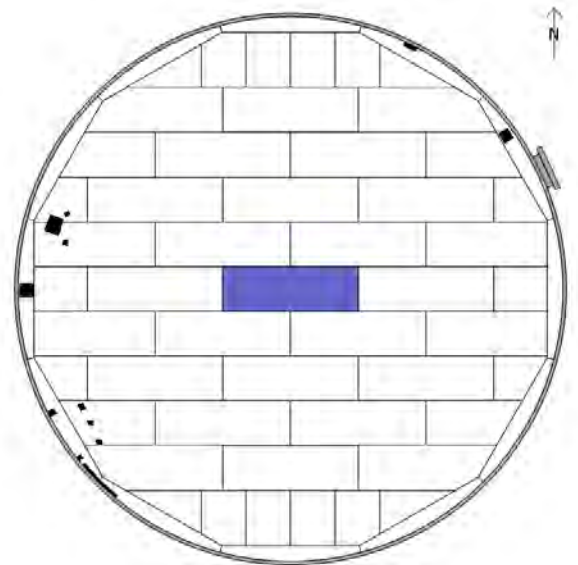
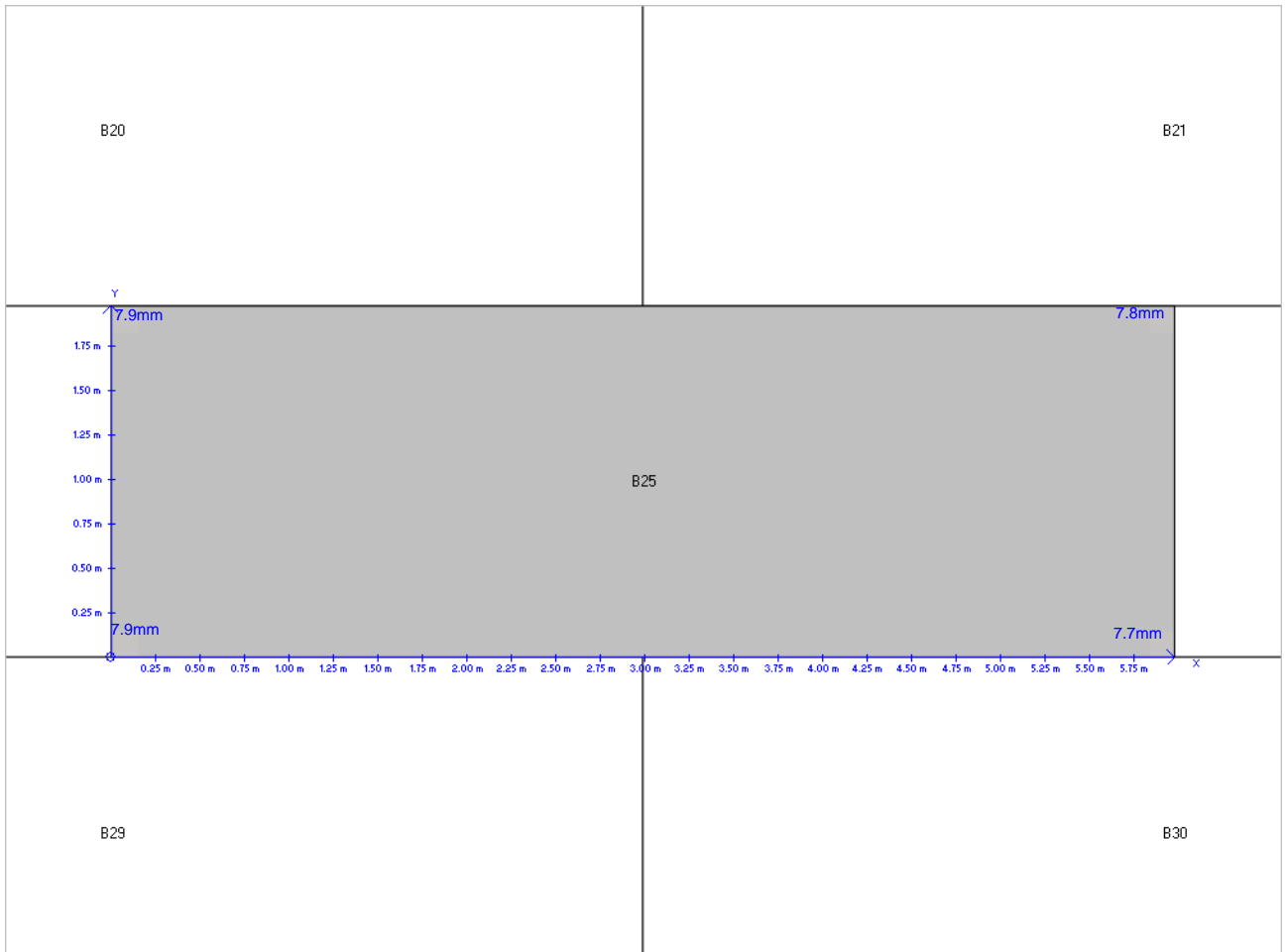

: Client a : Site b : 03/05/2016 : B 26	: Tank 123 : K0xx-16 : Jxx86
--	------------------------------------

Ultrasonic Thickness Readings

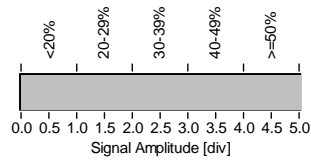
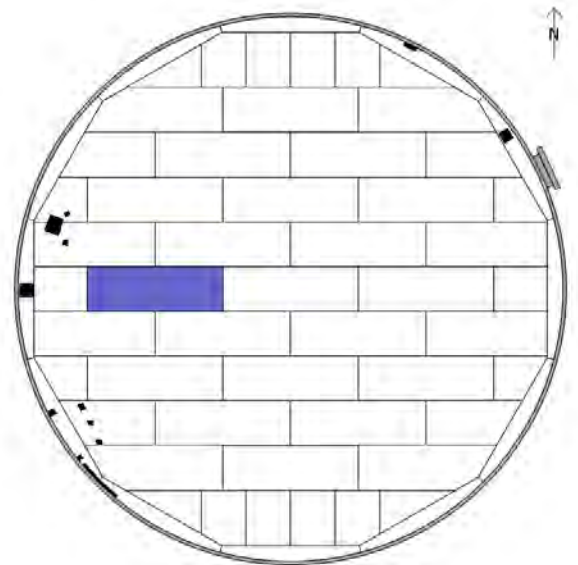

<ul style="list-style-type: none"> : Client a : Site b : 03/05/2016 : B 27 	<ul style="list-style-type: none"> : Tank 123 : K0xx-16 : Jxx86
--	--

Ultrasonic Thickness Readings

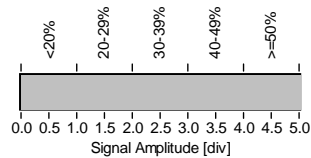
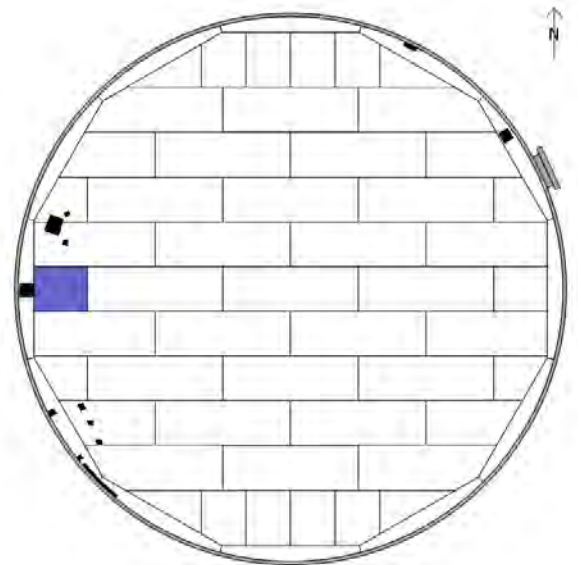
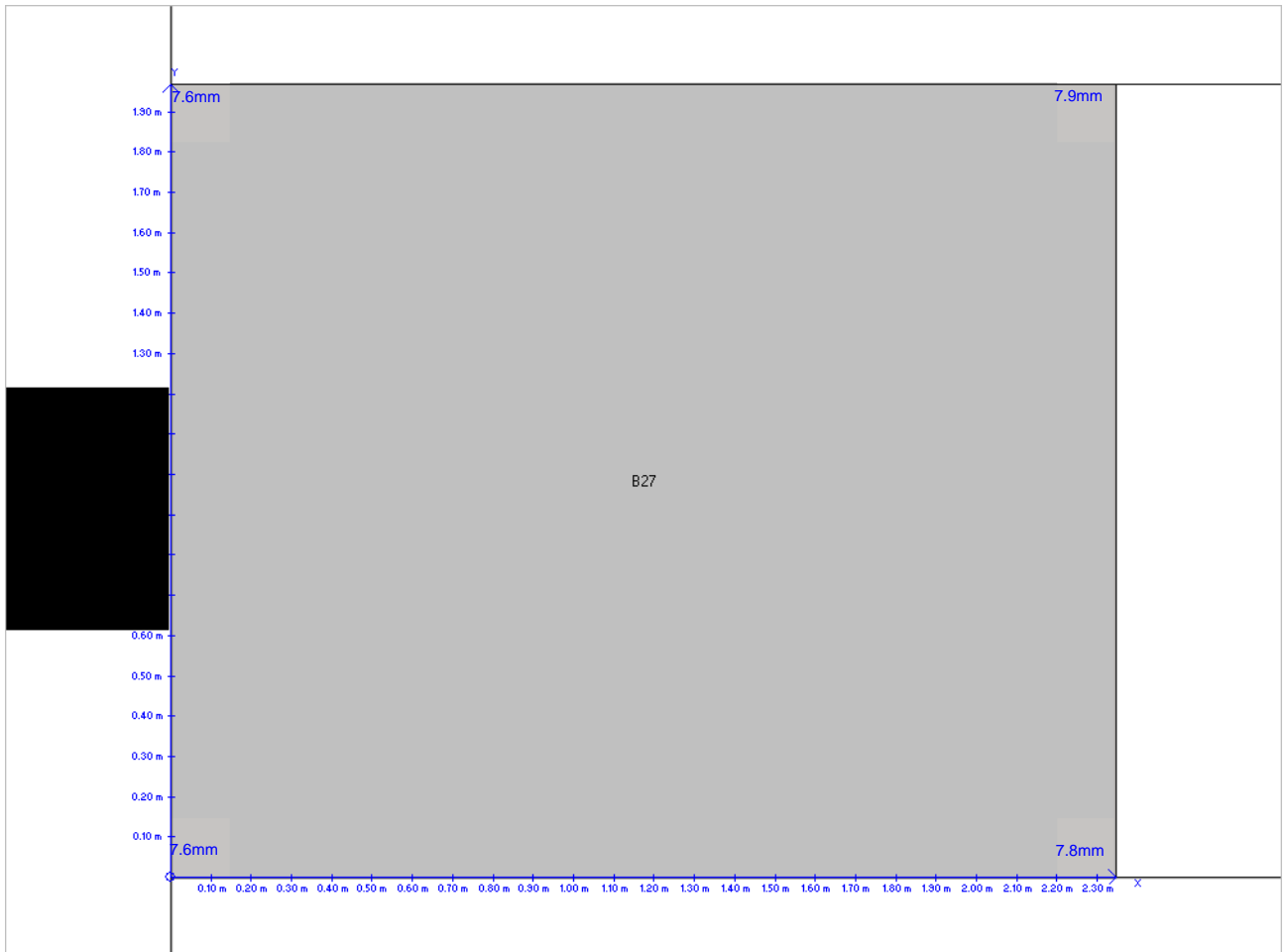

: Client a : Site b : 03/05/2016 : B 28	: Tank 123 : K0xx-16 : Jxx86
--	------------------------------------

Ultrasonic Thickness Readings

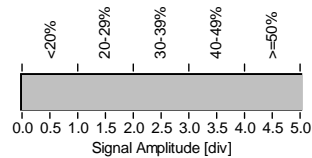
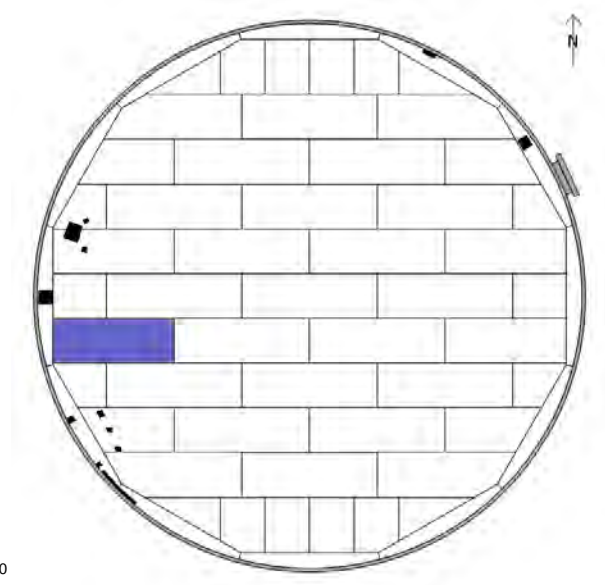
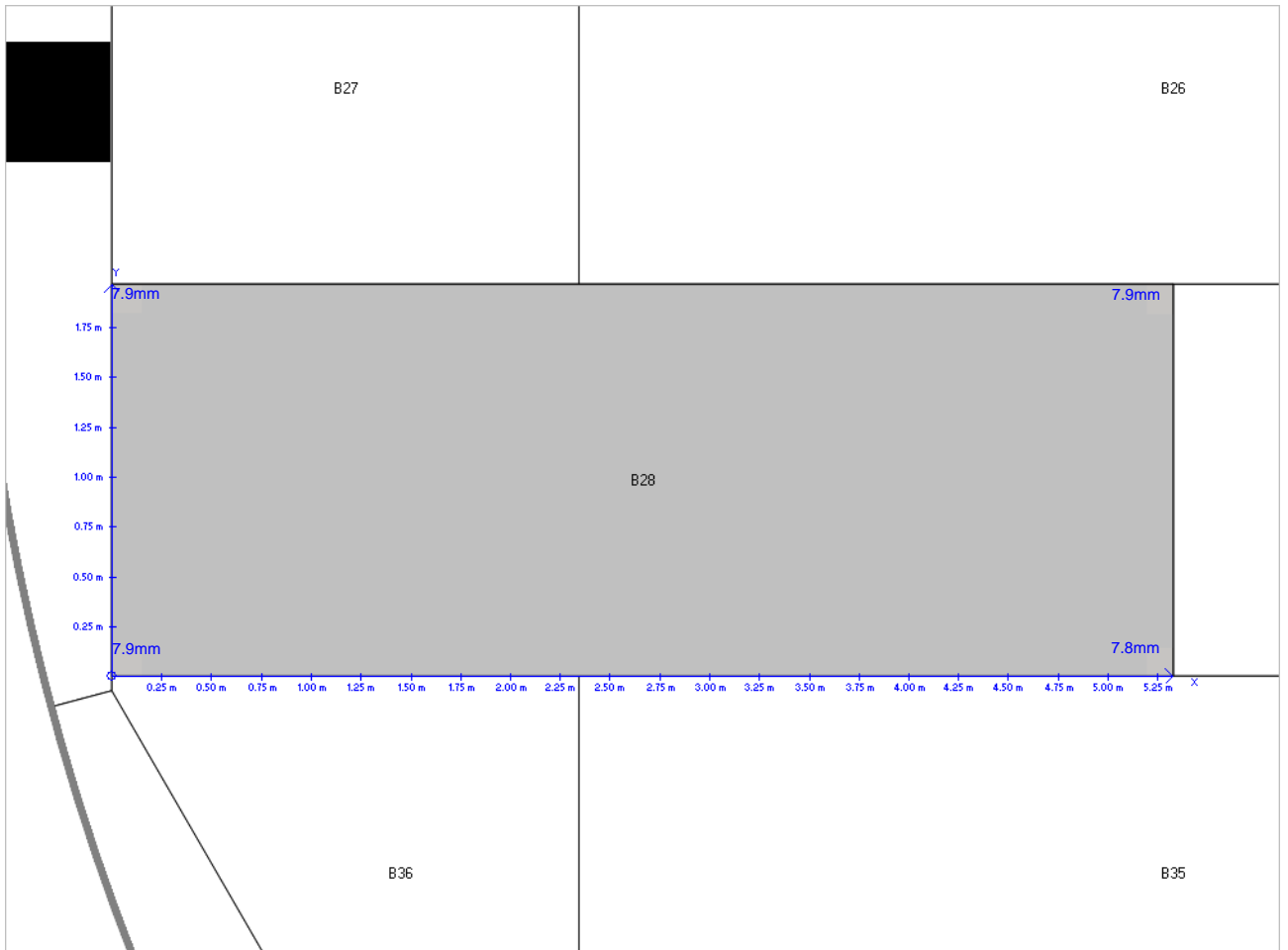

<ul style="list-style-type: none"> : Client a : Site b : 03/05/2016 : B 29 	<ul style="list-style-type: none"> : Tank 123 : K0xx-16 : Jxx86
--	--

Ultrasonic Thickness Readings

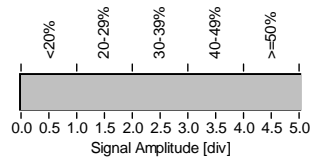
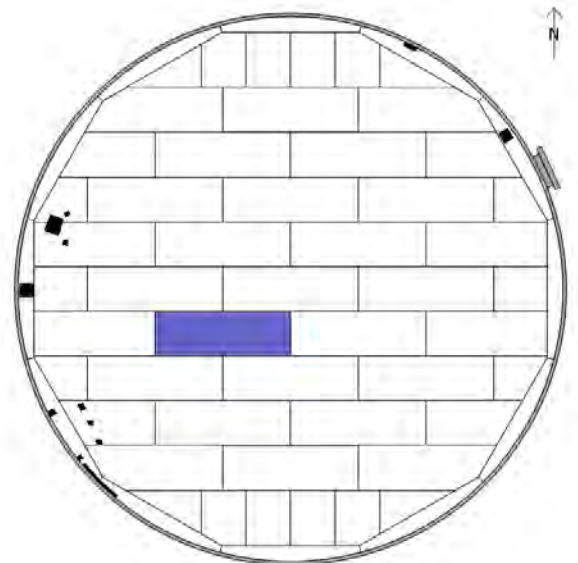
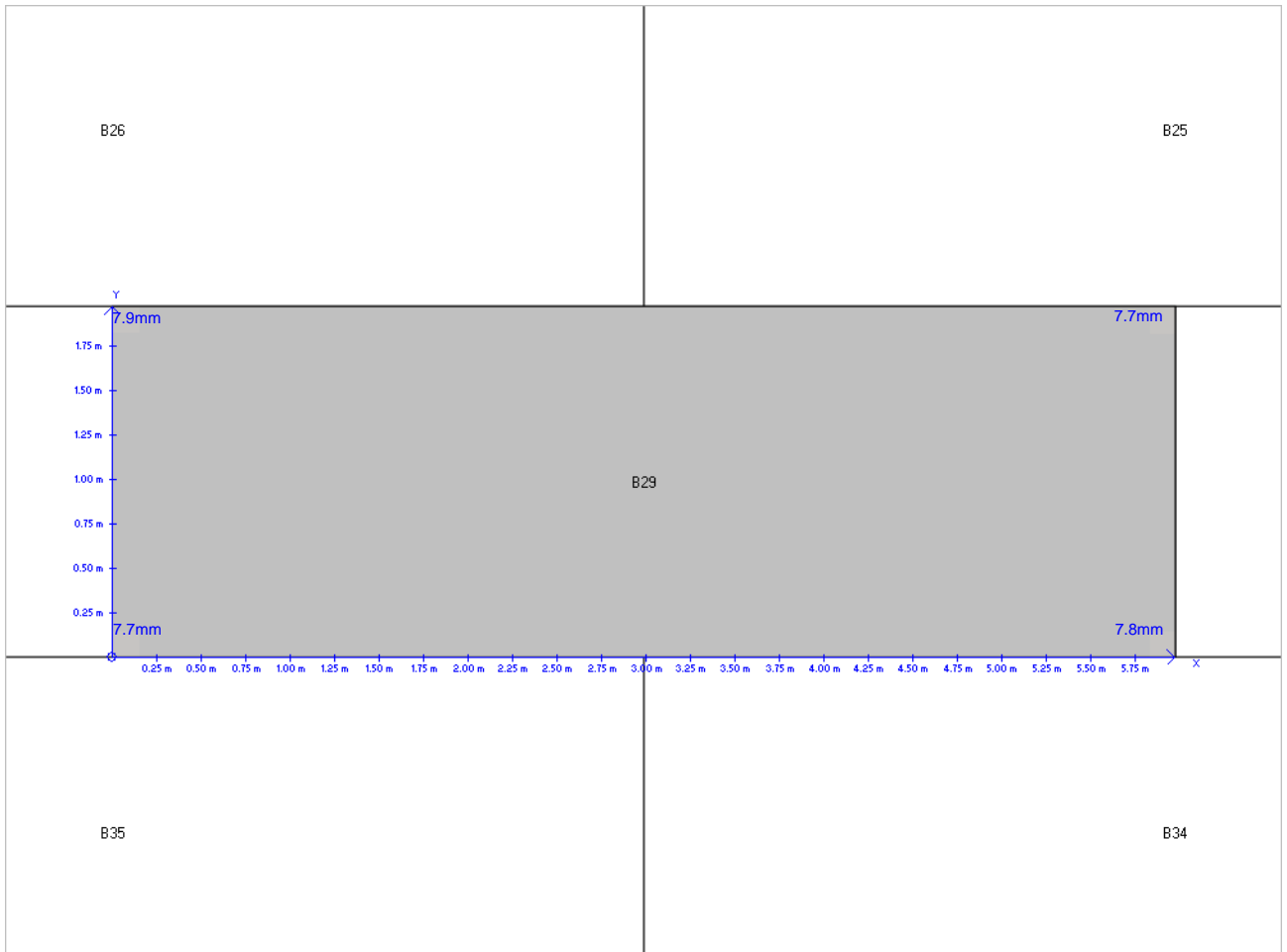

: Client a : Site b : 03/05/2016 : B 30	: Tank 123 : K0xx-16 : Jxx86
--	------------------------------------

Ultrasonic Thickness Readings

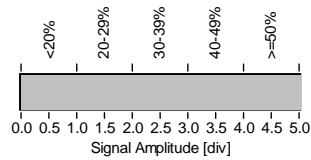
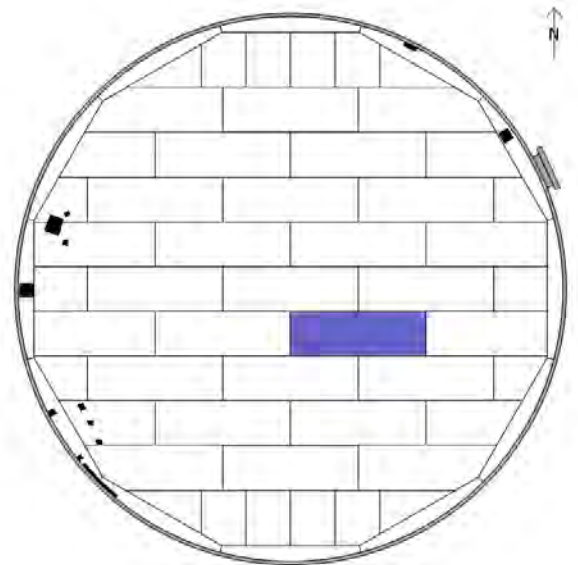
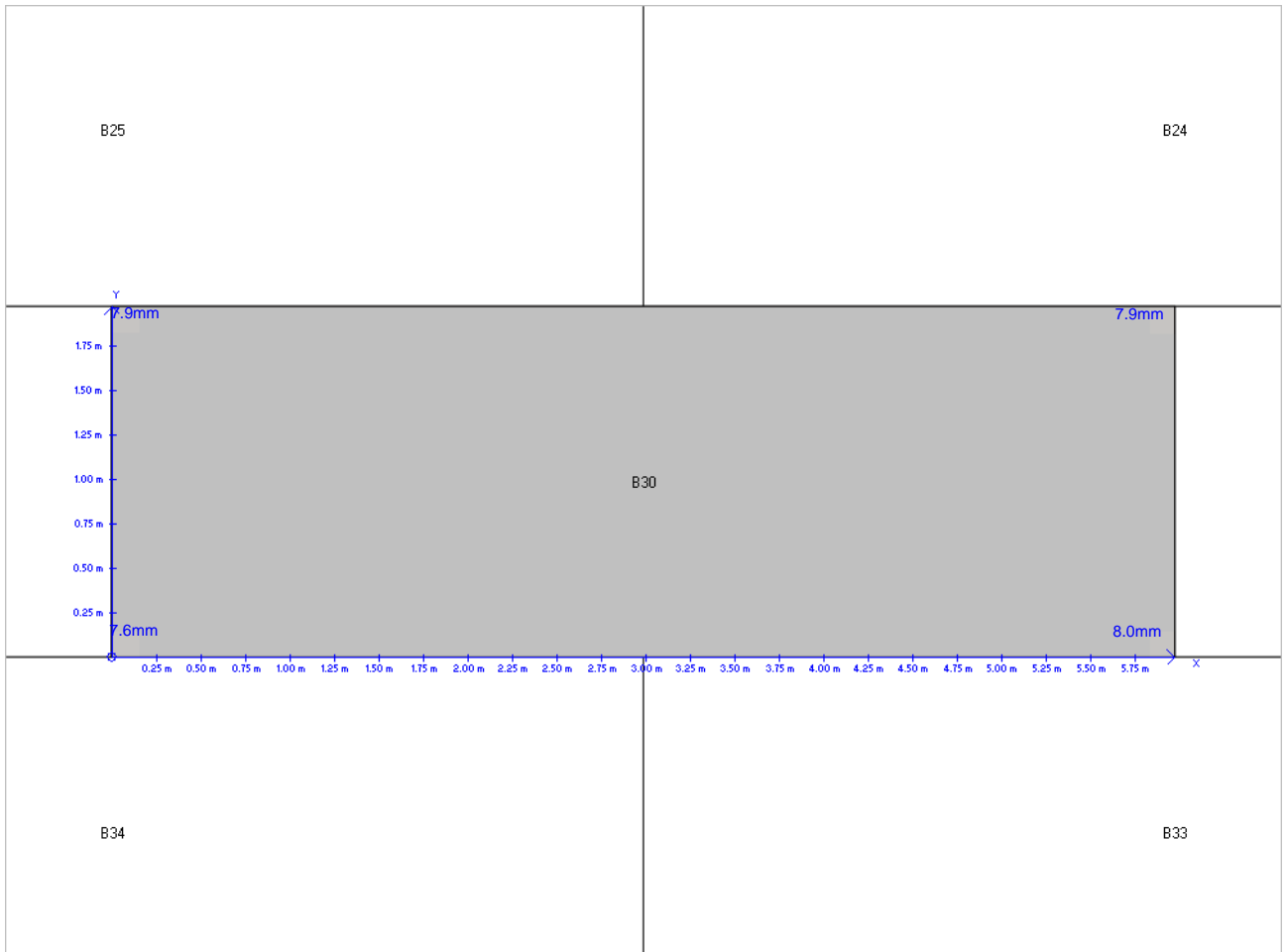

: Client a : Site b : 03/05/2016 : B 31	: Tank 123 : K0xx-16 : Jxx86
--	------------------------------------

Ultrasonic Thickness Readings

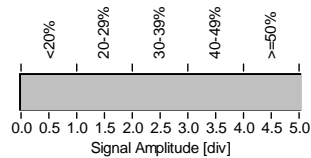
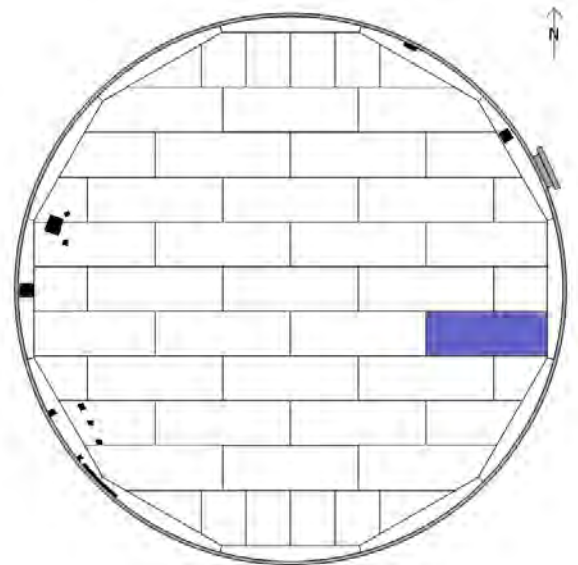
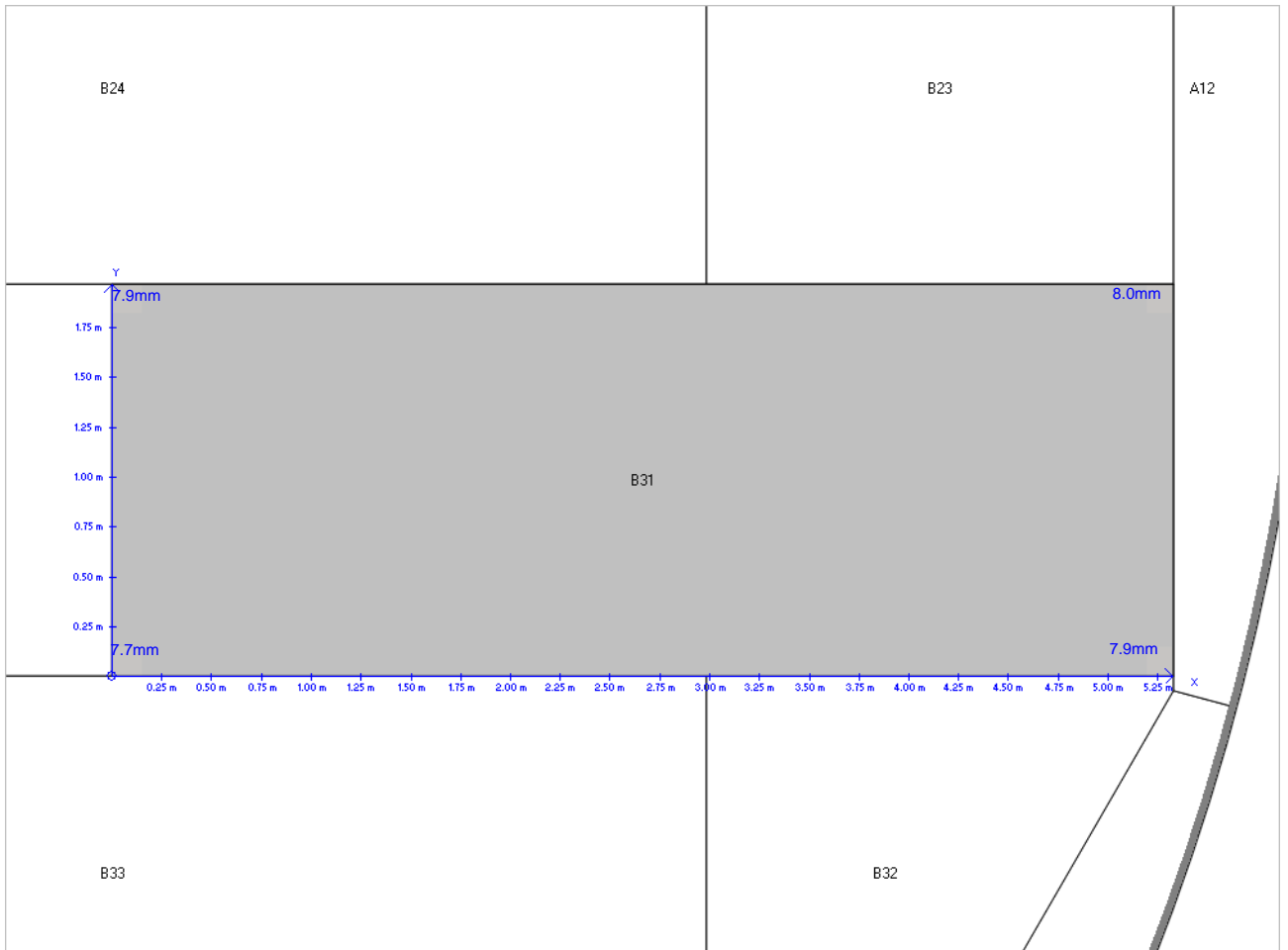

<ul style="list-style-type: none"> : Client a : Site b : 03/05/2016 : B 32 	<ul style="list-style-type: none"> : Tank 123 : K0xx-16 : Jxx86
--	--

Ultrasonic Thickness Readings

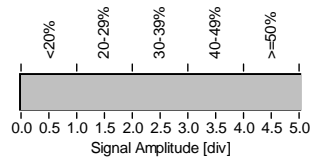
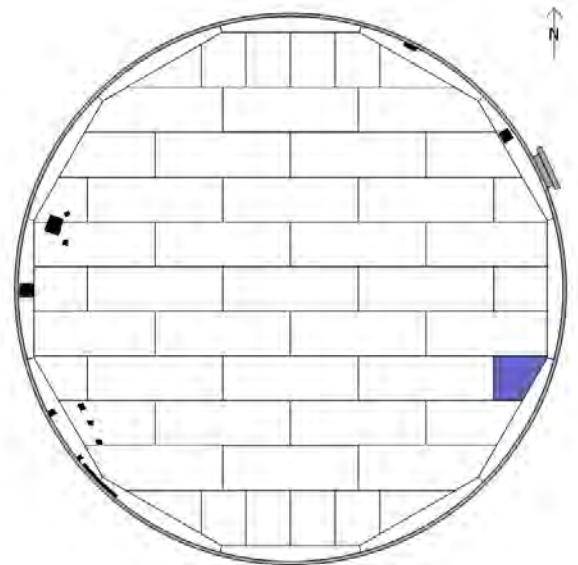
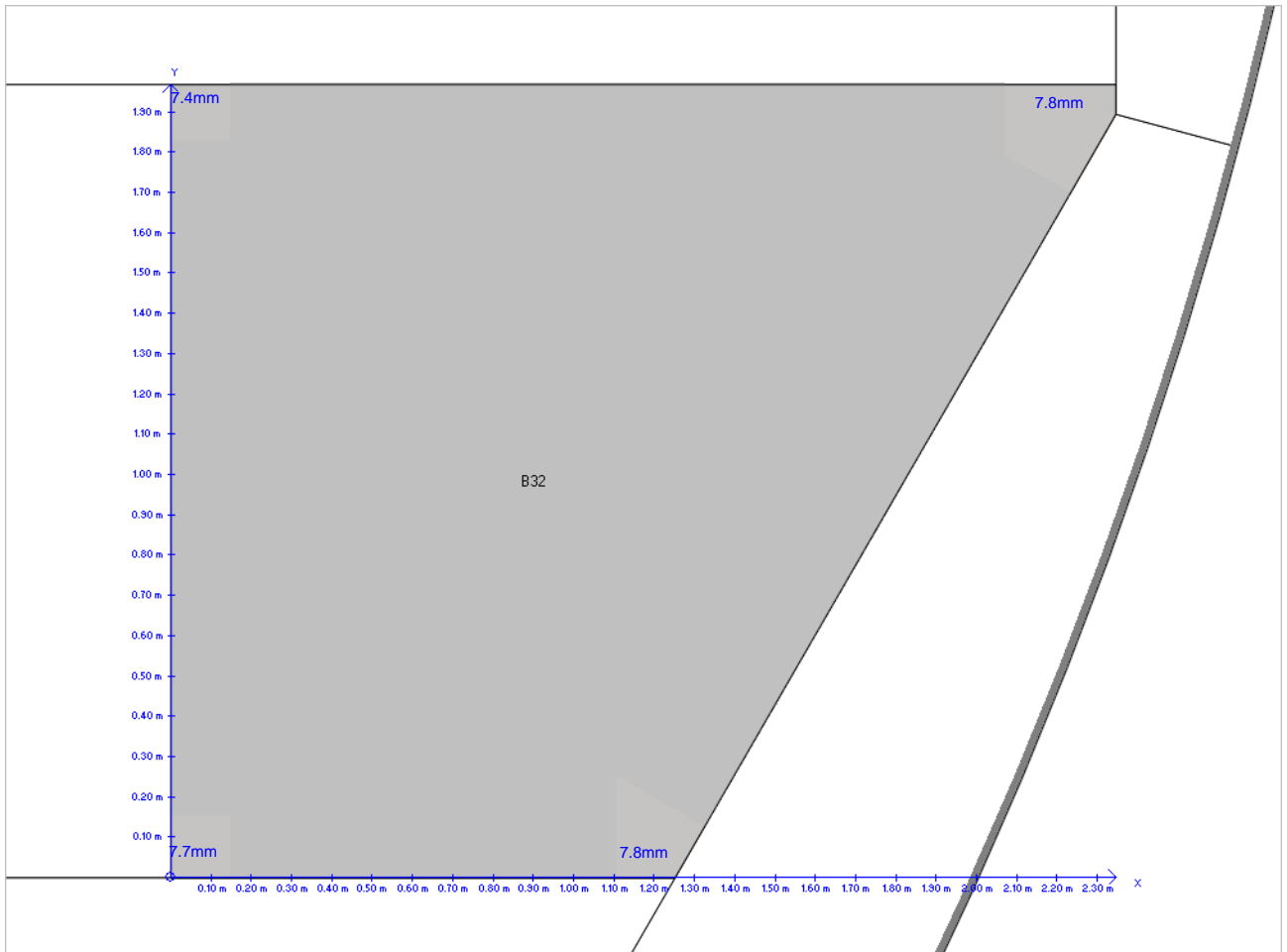

: Client a : Site b : 03/05/2016 : B 33	: Tank 123 : K0xx-16 : Jxx86
--	------------------------------------

Ultrasonic Thickness Readings

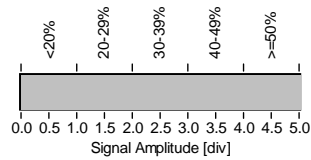
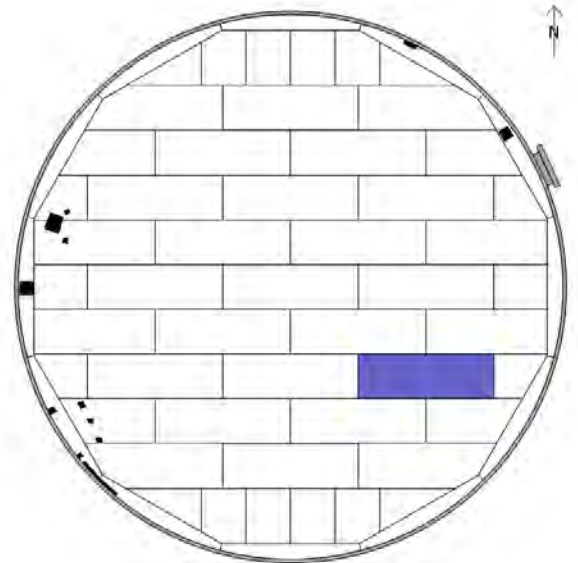
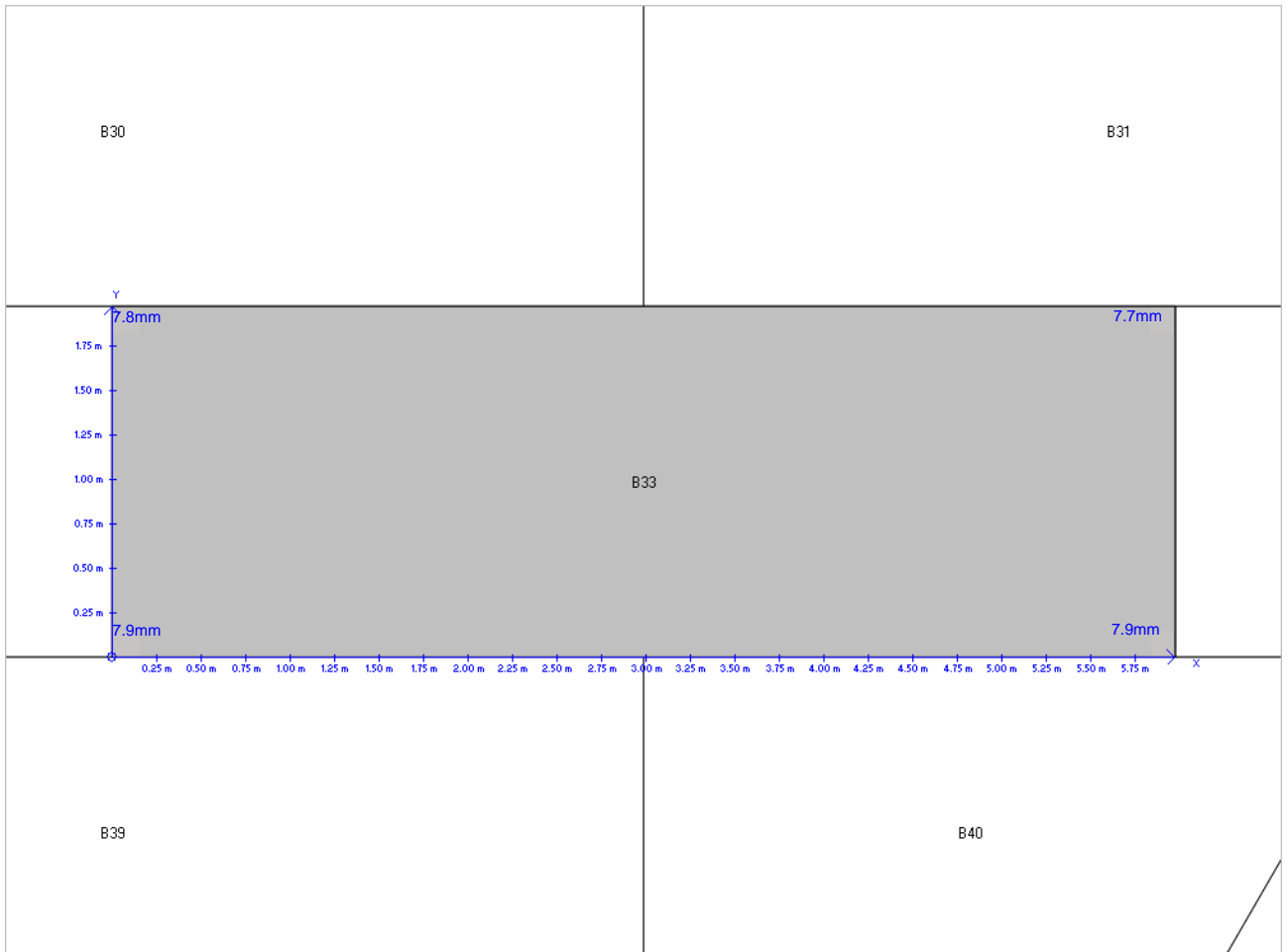

: Client a : Site b : 03/05/2016 : B 34	: Tank 123 : K0xx-16 : Jxx86
--	------------------------------------

Ultrasonic Thickness Readings

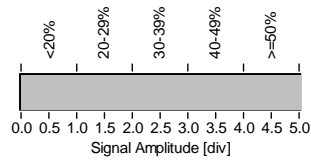
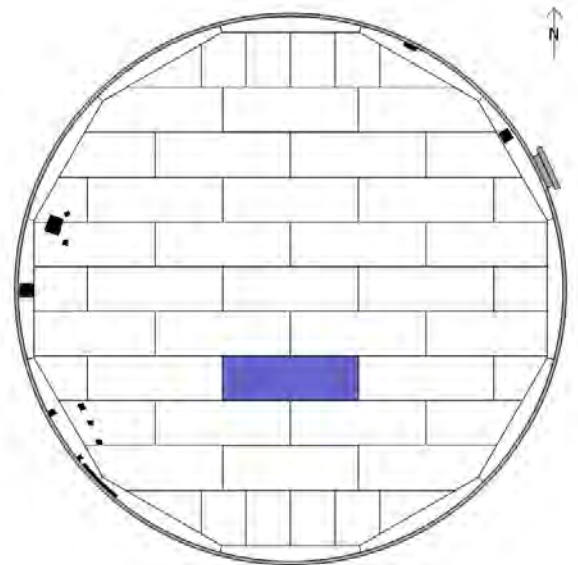
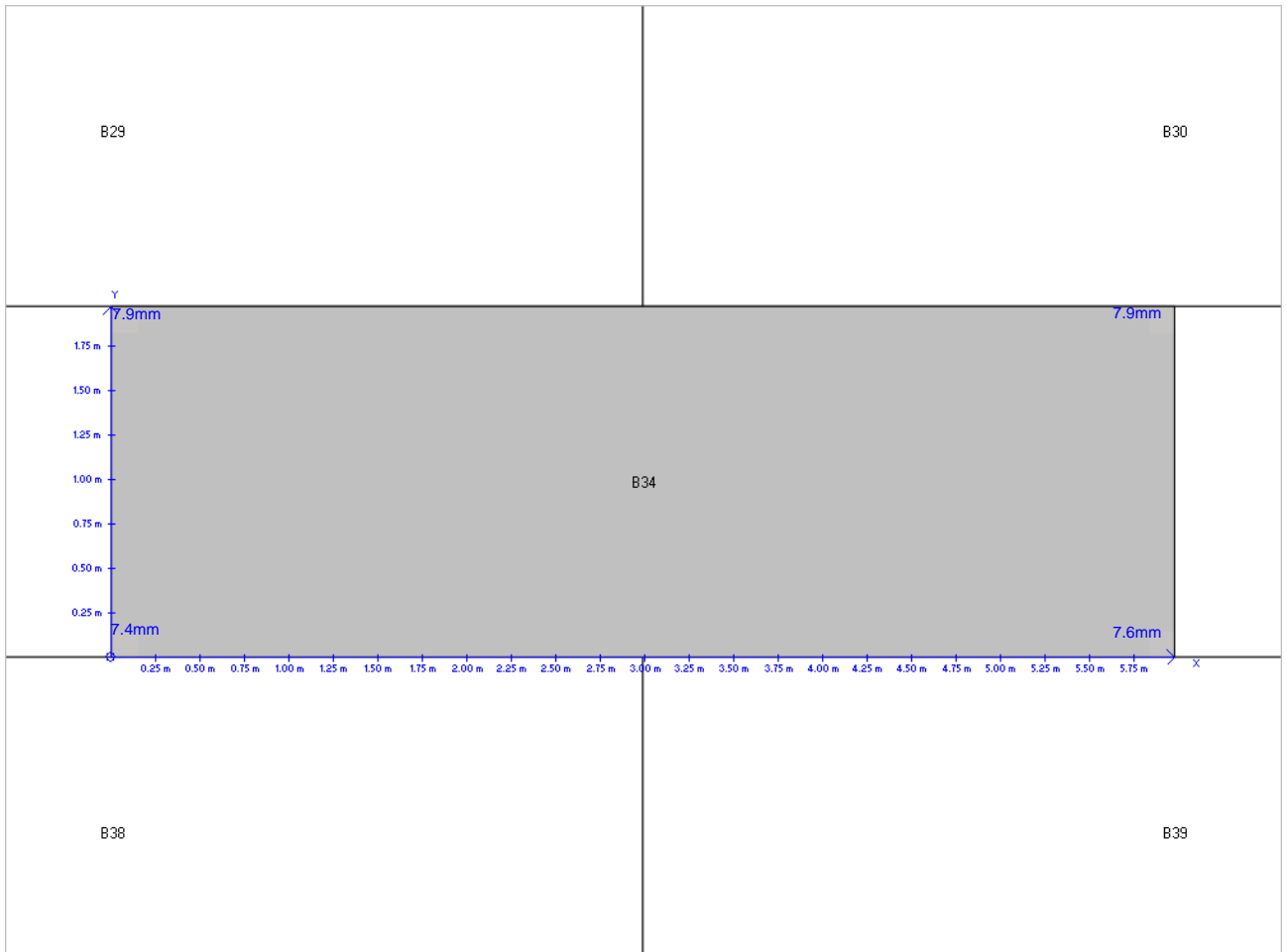

<ul style="list-style-type: none"> : Client a : Site b : 03/05/2016 : B 35 	<ul style="list-style-type: none"> : Tank 123 : K0xx-16 : Jxx86
--	--

Ultrasonic Thickness Readings

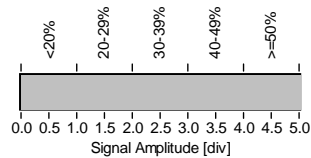
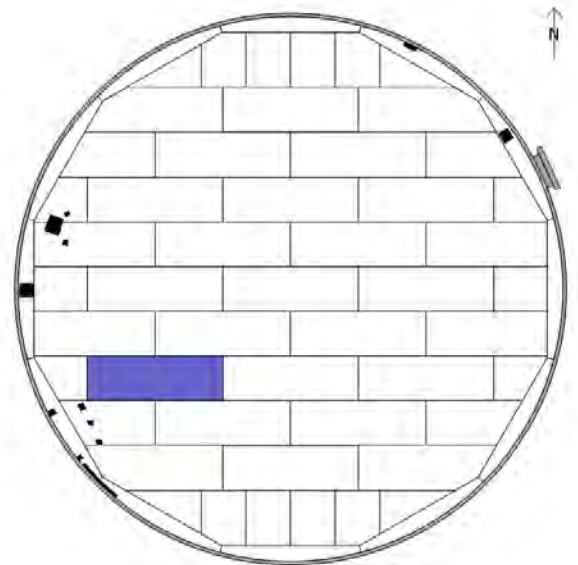
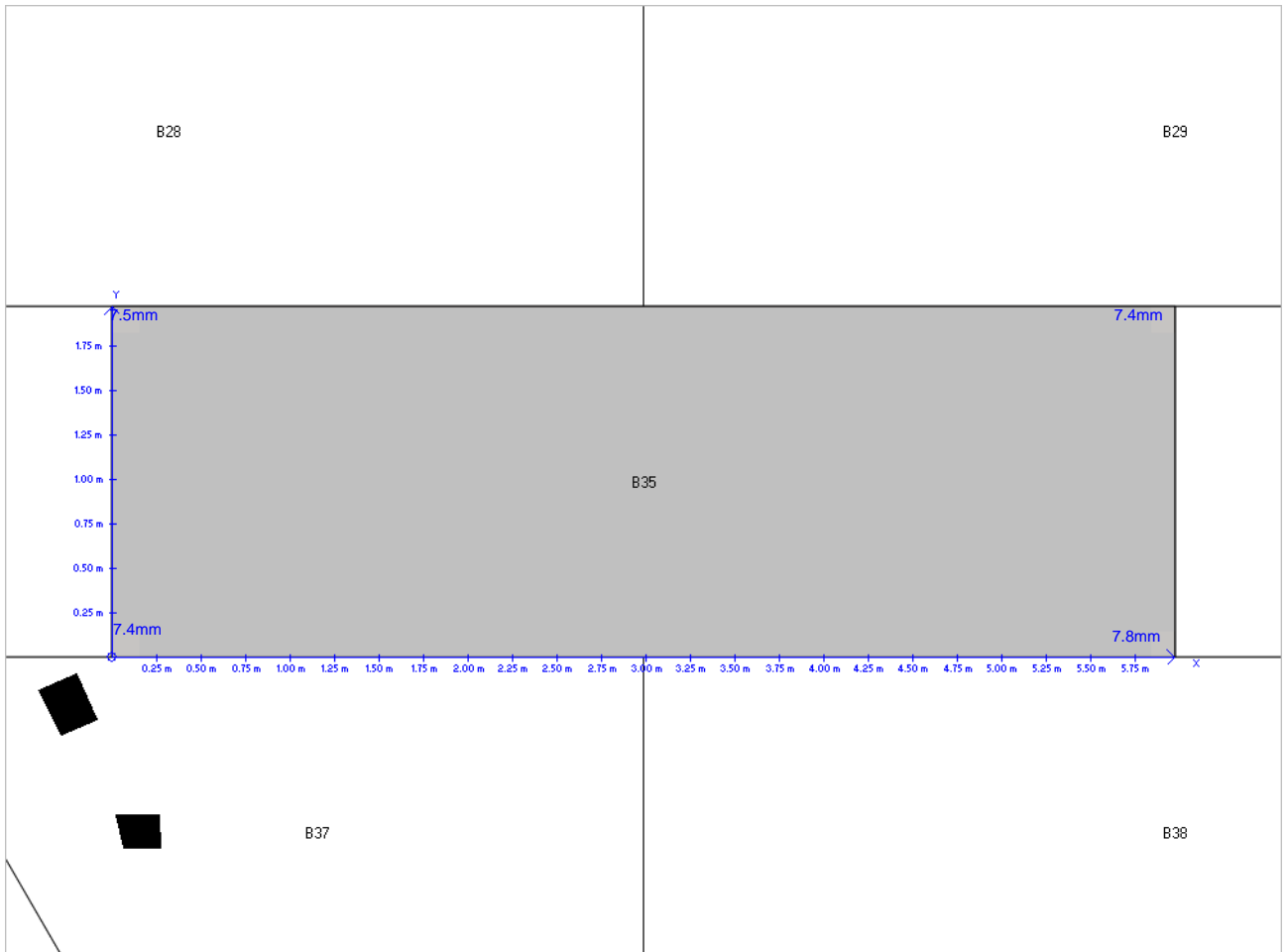

<ul style="list-style-type: none"> : Client a : Site b : 03/05/2016 : B 36 	<ul style="list-style-type: none"> : Tank 123 : K0xx-16 : Jxx86
--	--

Ultrasonic Thickness Readings

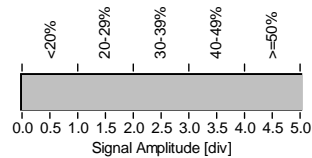
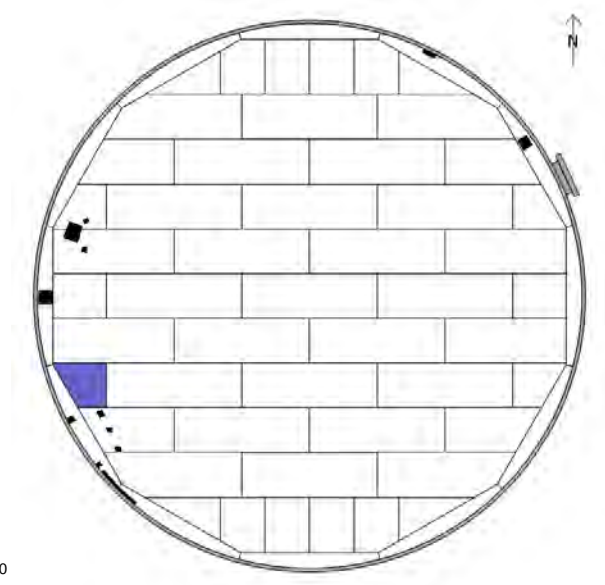
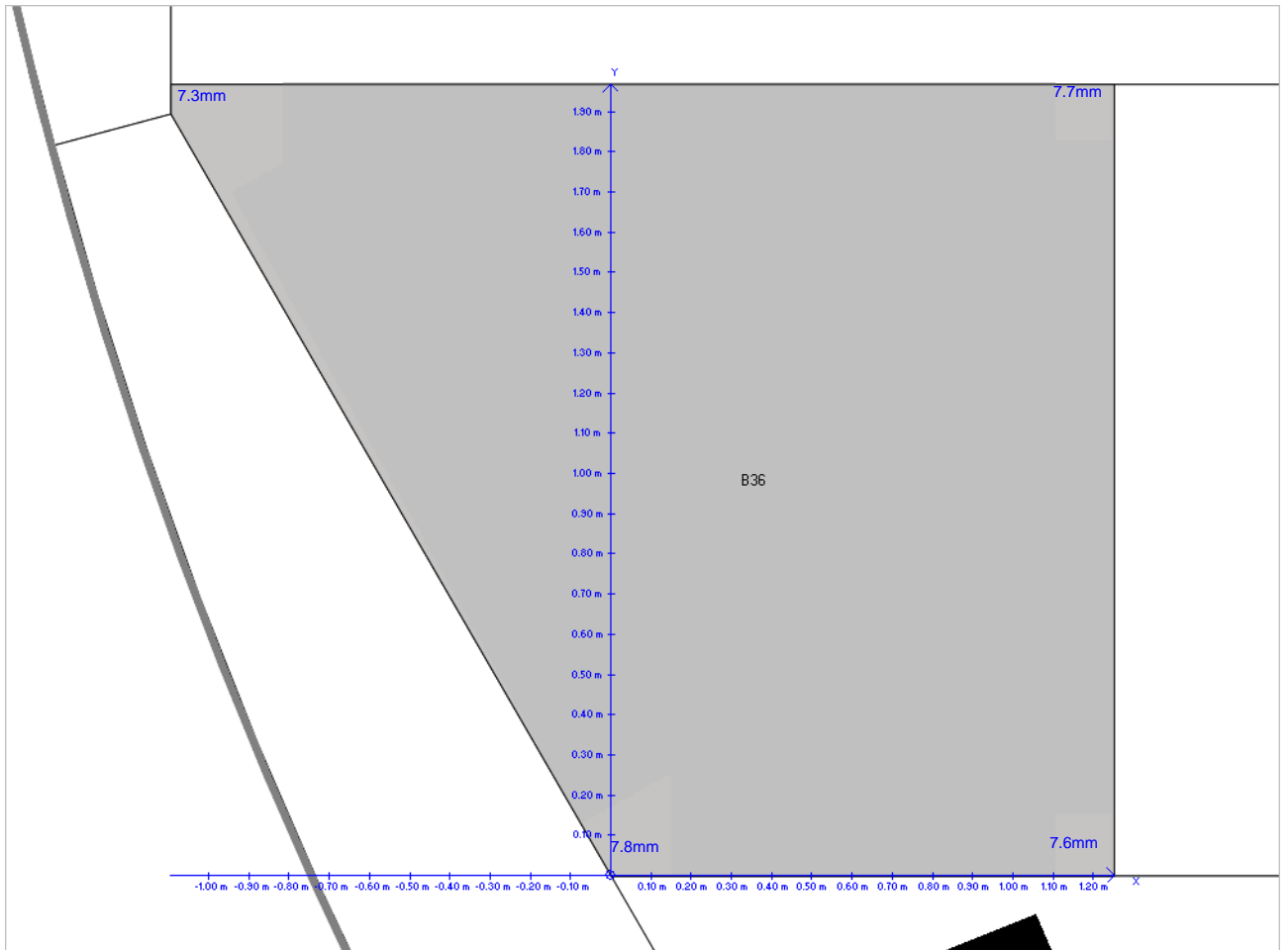

<ul style="list-style-type: none"> : Client a : Site b : 03/05/2016 : B 37 	<ul style="list-style-type: none"> : Tank 123 : K0xx-16 : Jxx86
--	--

Ultrasonic Thickness Readings

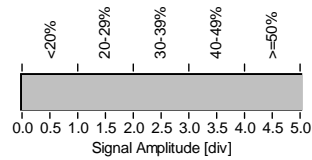
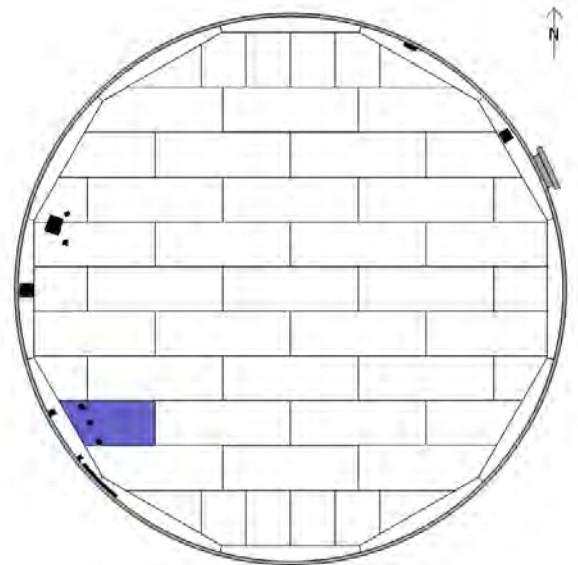
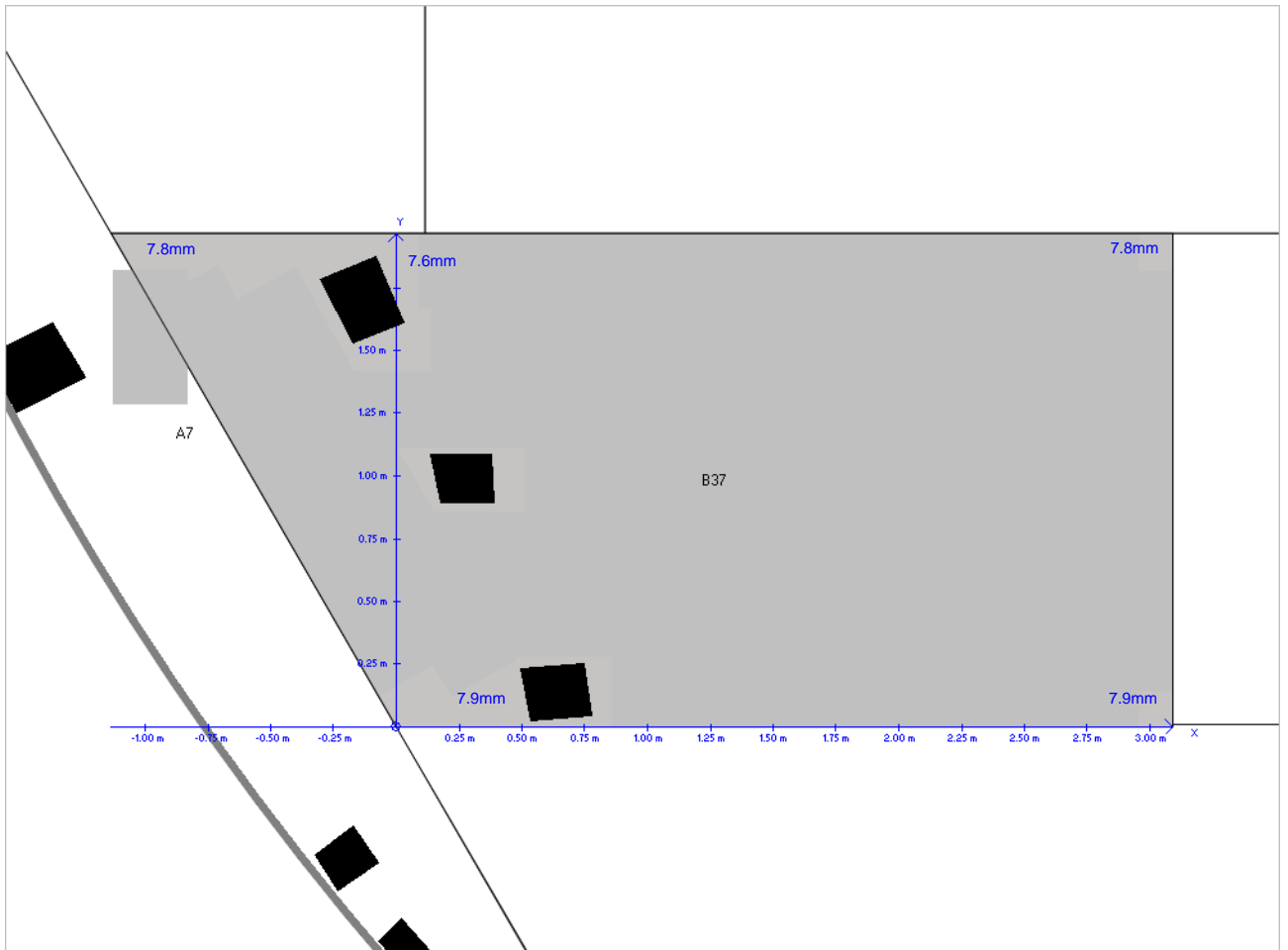

<ul style="list-style-type: none"> : Client a : Site b : 03/05/2016 : B 38 	<ul style="list-style-type: none"> : Tank 123 : K0xx-16 : Jxx86
--	--

Ultrasonic Thickness Readings

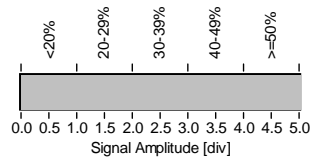
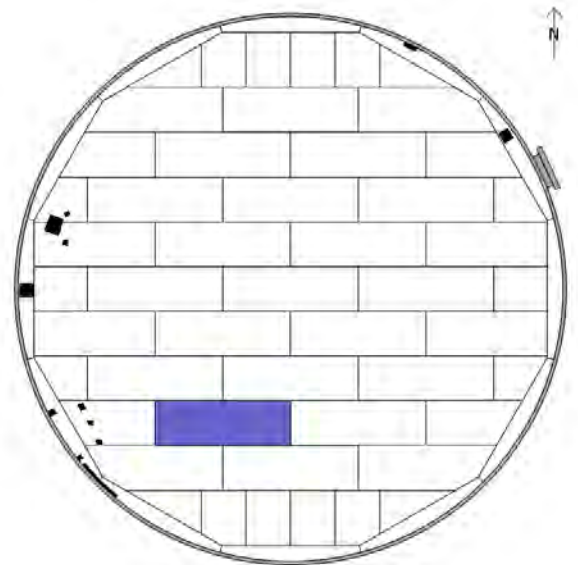
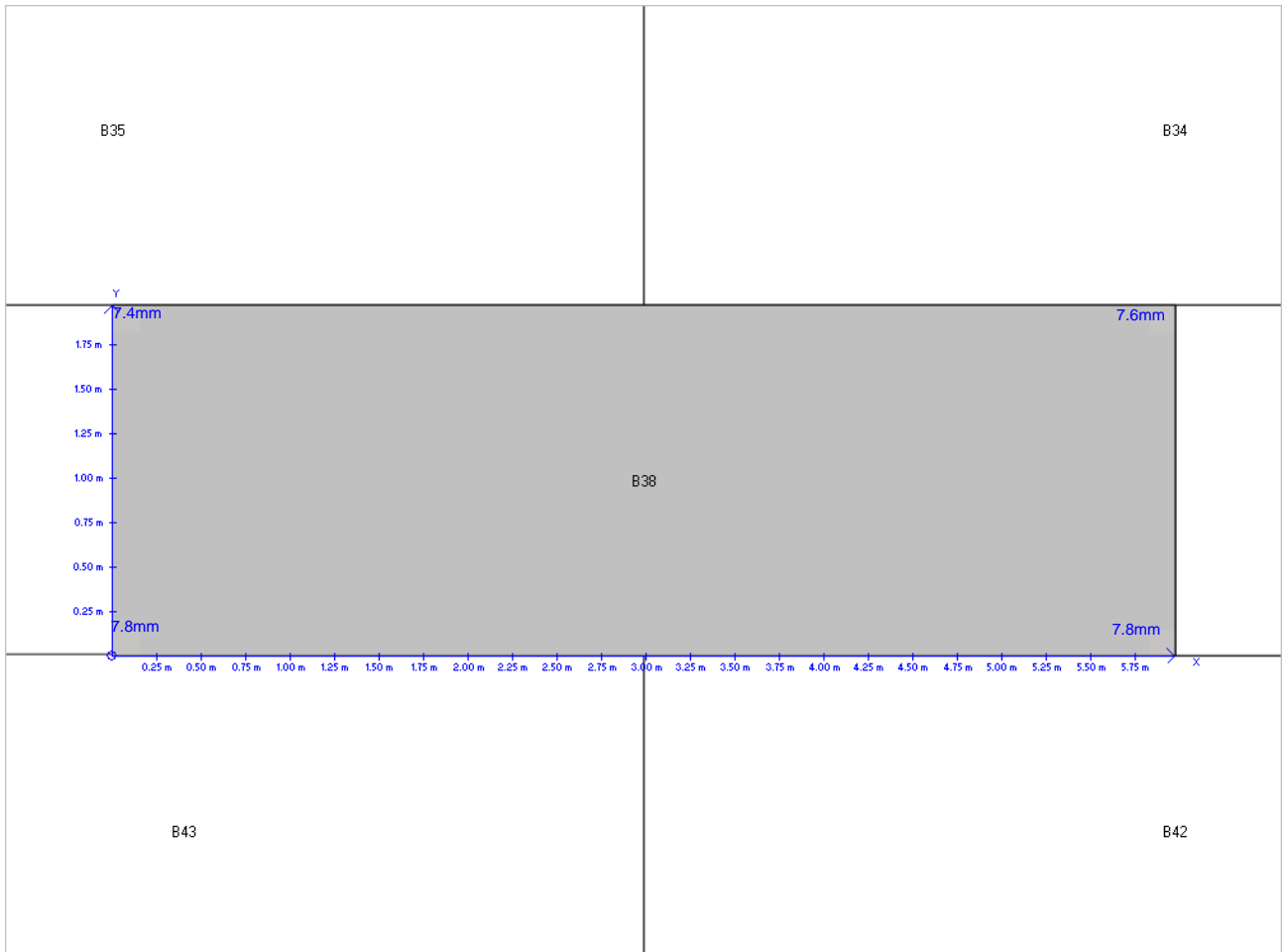

: Client a : Site b : 03/05/2016 : B 39	: Tank 123 : K0xx-16 : Jxx86
--	------------------------------------

Ultrasonic Thickness Readings

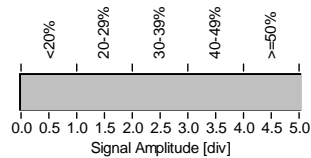
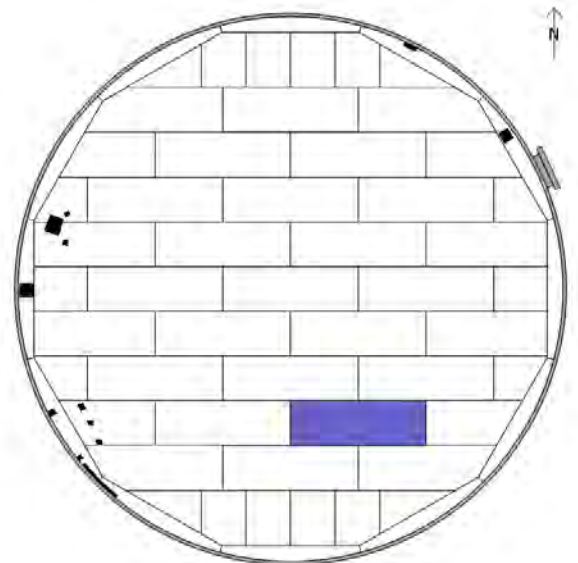
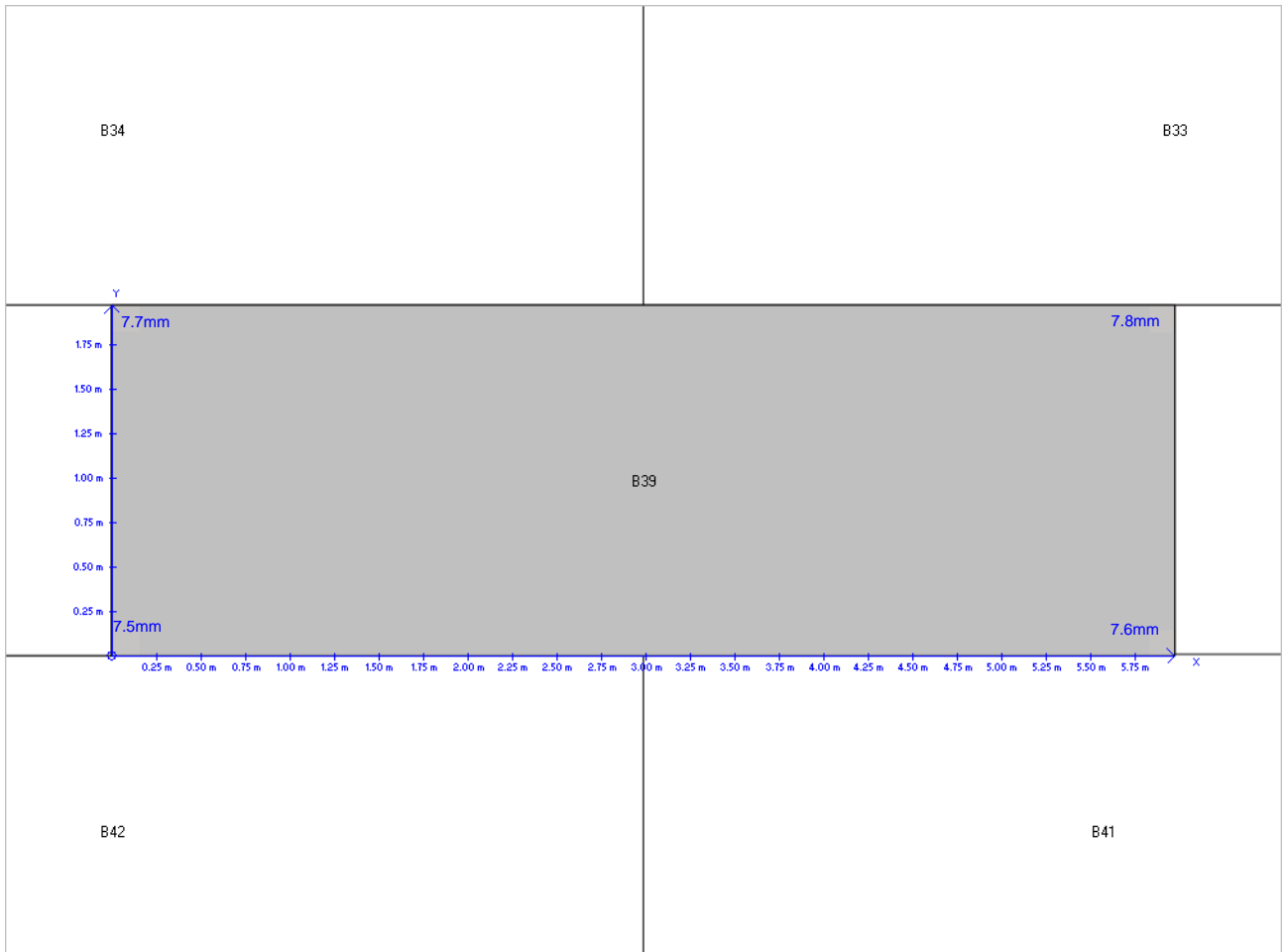

: Client a	: Tank 123
: Site b	: K0xx-16
: 03/05/2016	: Jxx86
: B 40	

Ultrasonic Thickness Readings

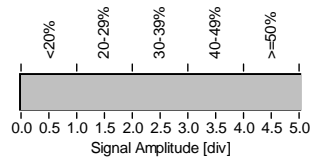
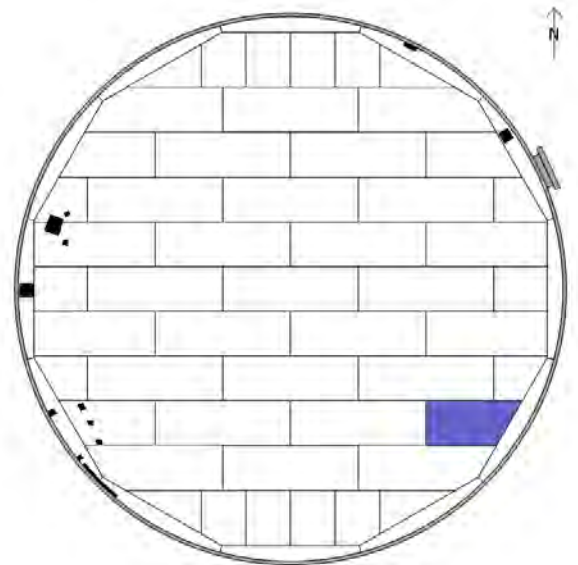
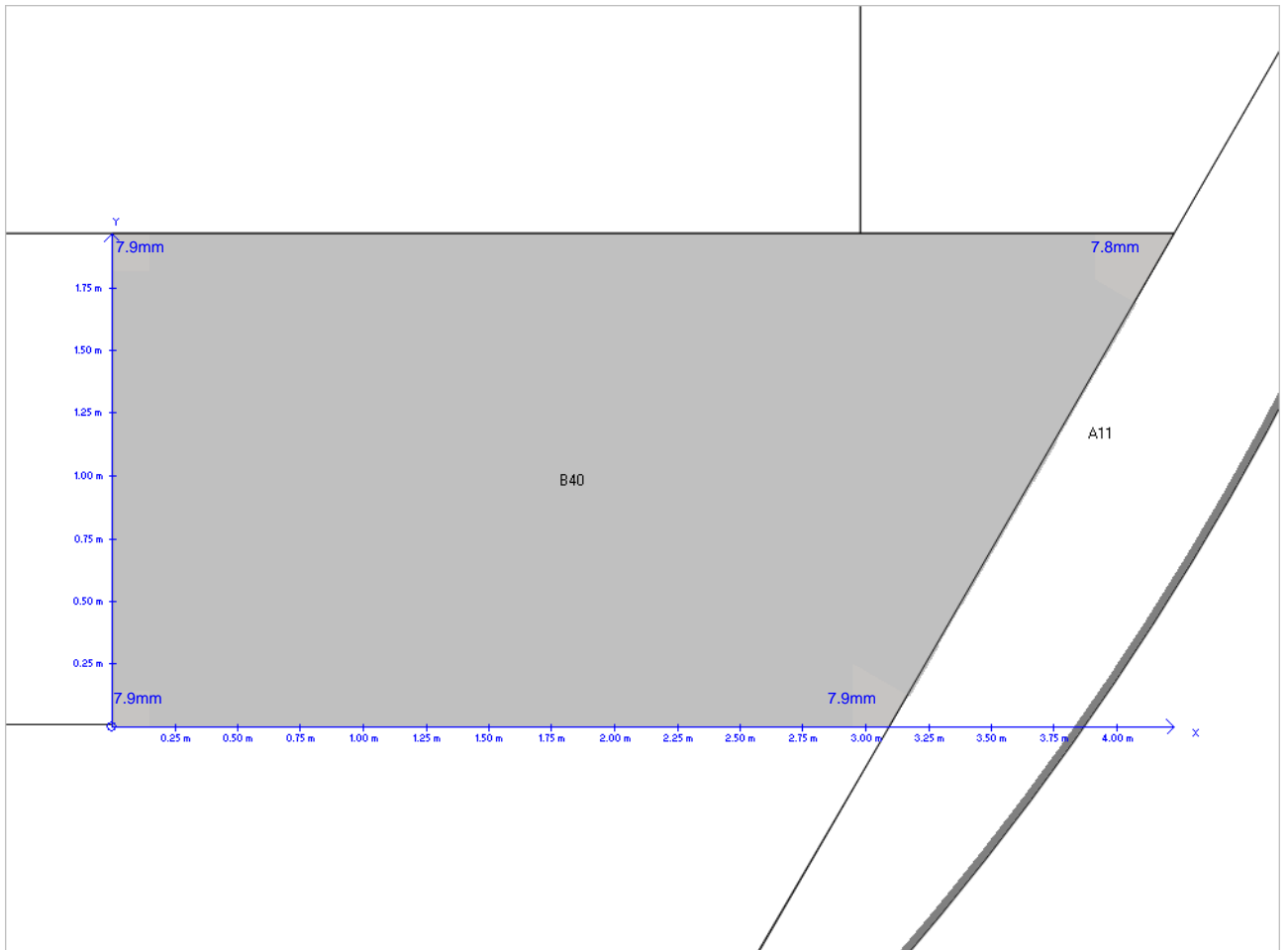

: Client a	: Tank 123
: Site b	: K0xx-16
: 03/05/2016	: Jxx86
: B 41	

Ultrasonic Thickness Readings

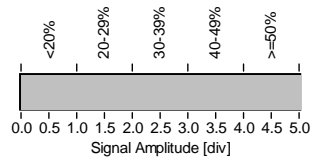
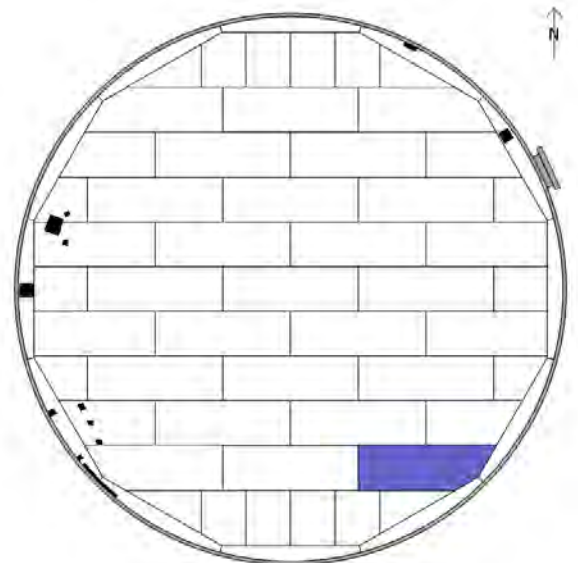
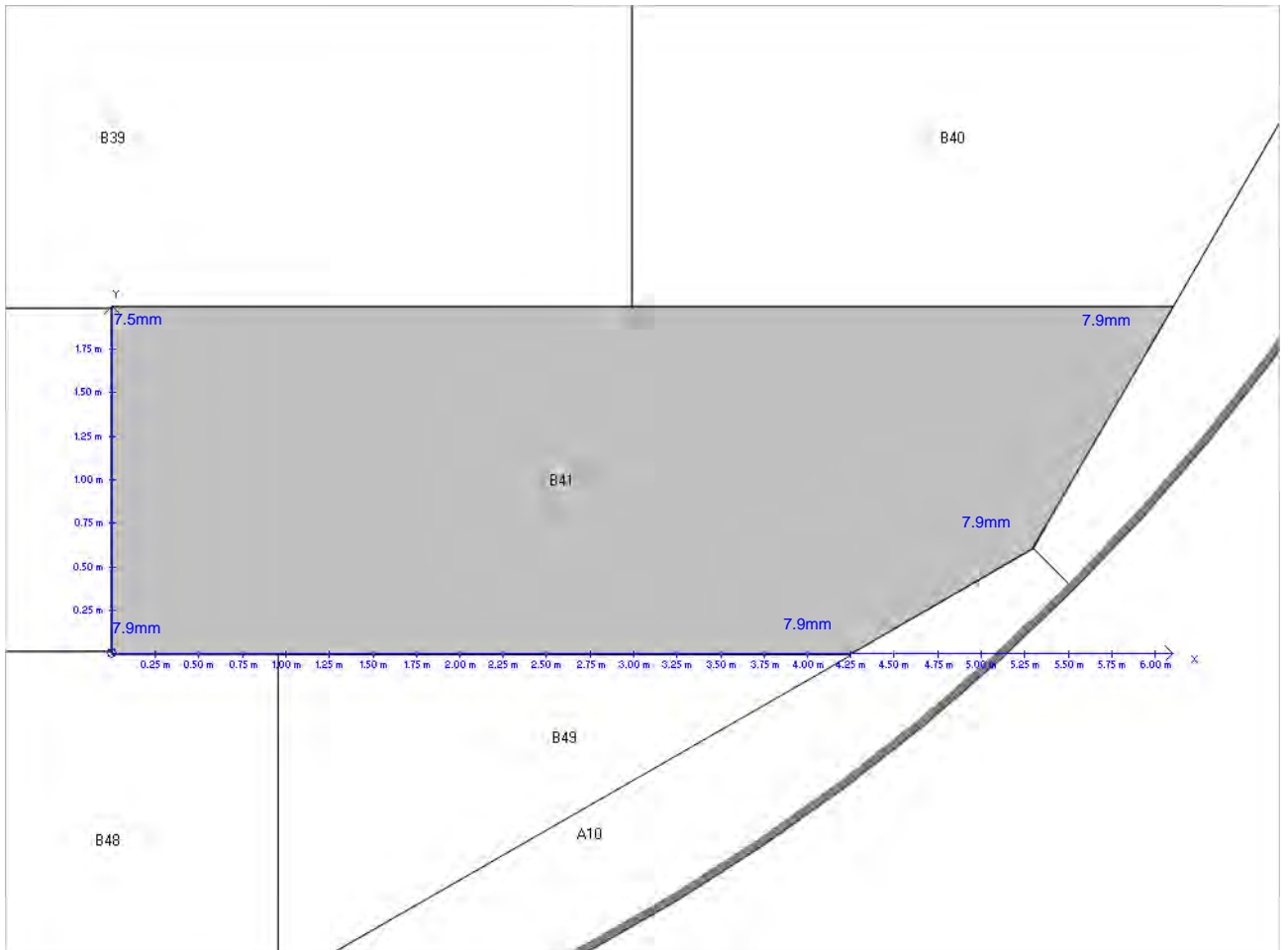

: Client a : Site b : 03/05/2016 : B 42	: Tank 123 : K0xx-16 : Jxx86
--	------------------------------------

Ultrasonic Thickness Readings

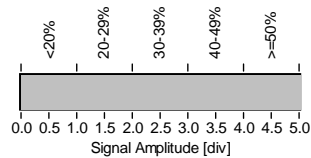
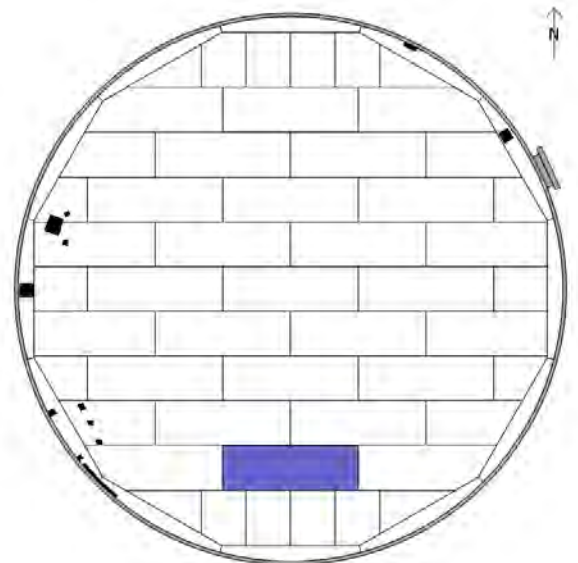
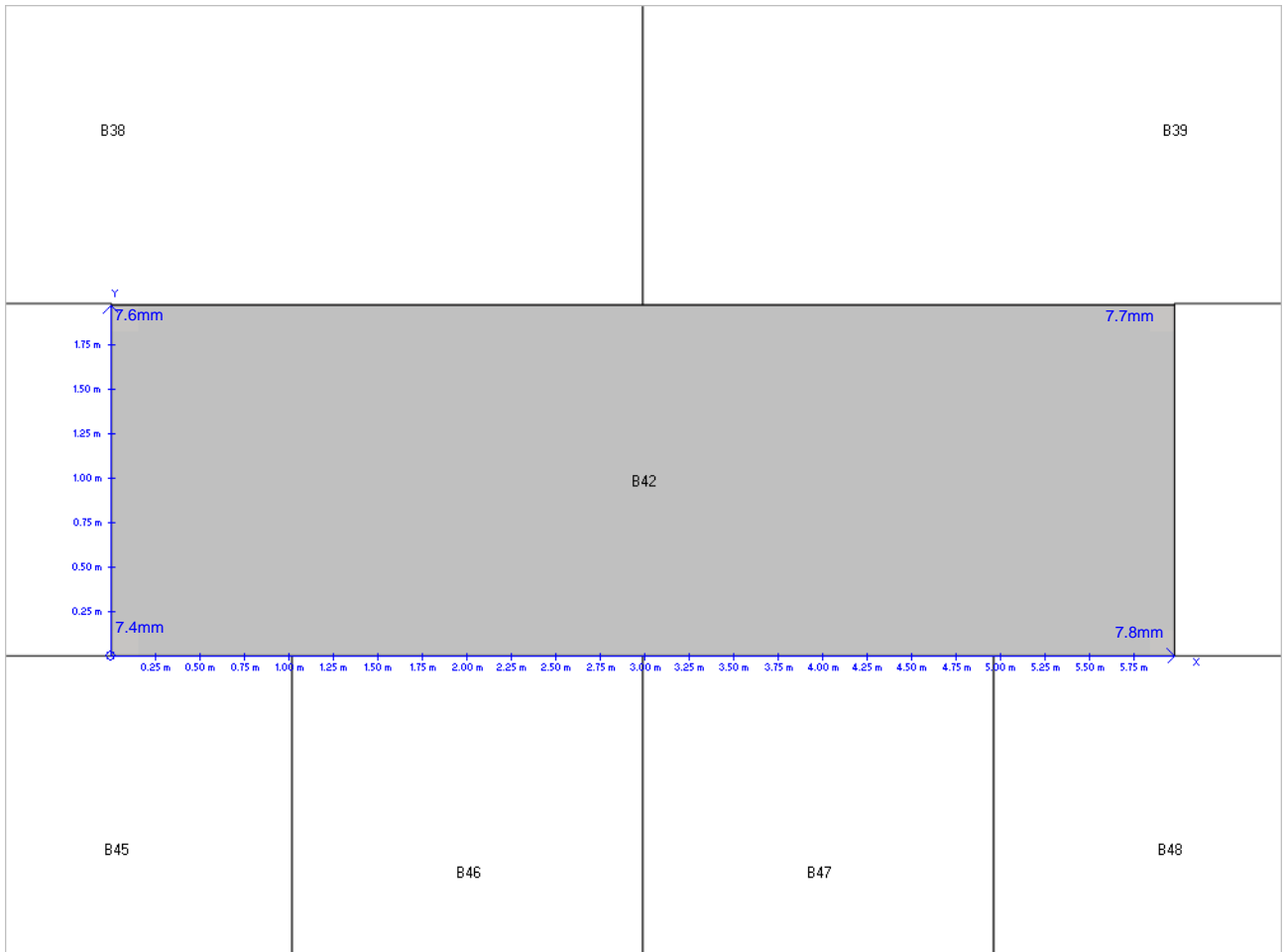

<ul style="list-style-type: none"> : Client a : Site b : 03/05/2016 : B 43 	<ul style="list-style-type: none"> : Tank 123 : K0xx-16 : Jxx86
--	--

Ultrasonic Thickness Readings

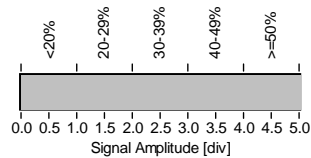
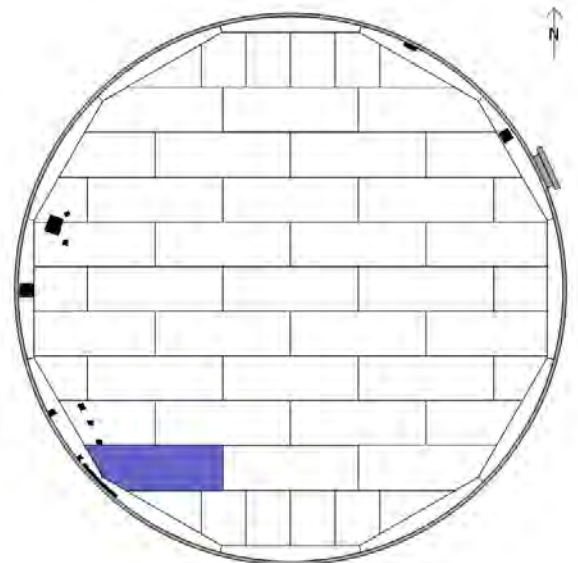
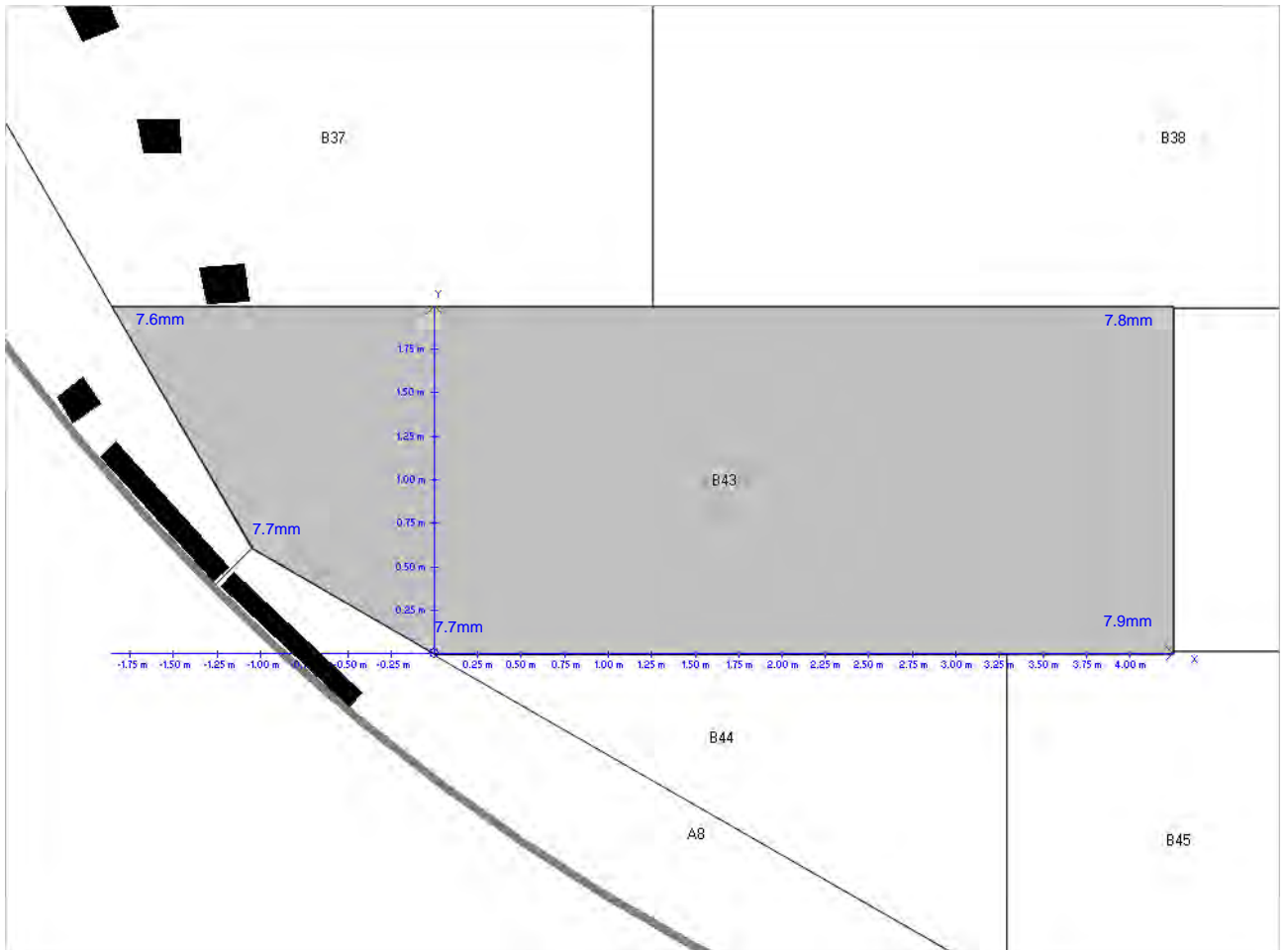

: Client a	: Tank 123
: Site b	: K0xx-16
: 03/05/2016	: Jxx86
: B 44	

Ultrasonic Thickness Readings

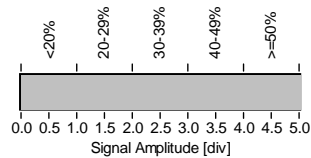
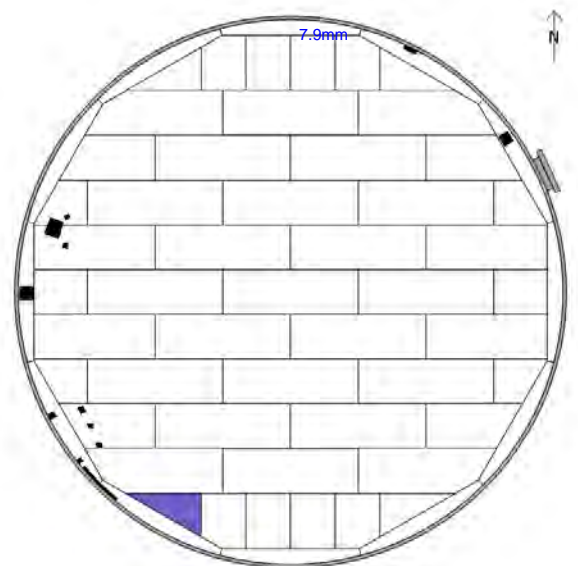
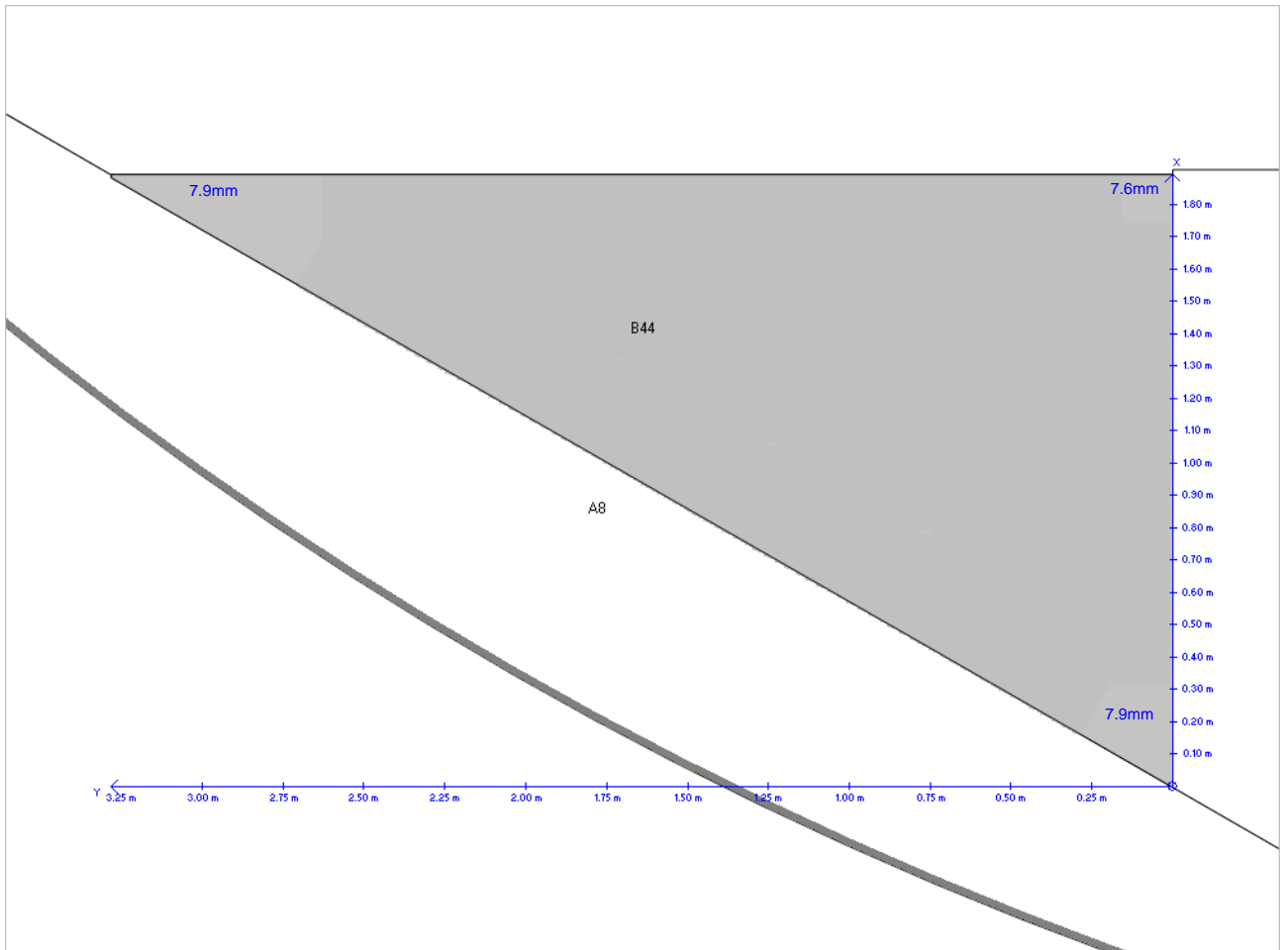

: Client a : Site b : 03/05/2016 : B 45	: Tank 123 : K0xx-16 : Jxx86
--	------------------------------------

Ultrasonic Thickness Readings

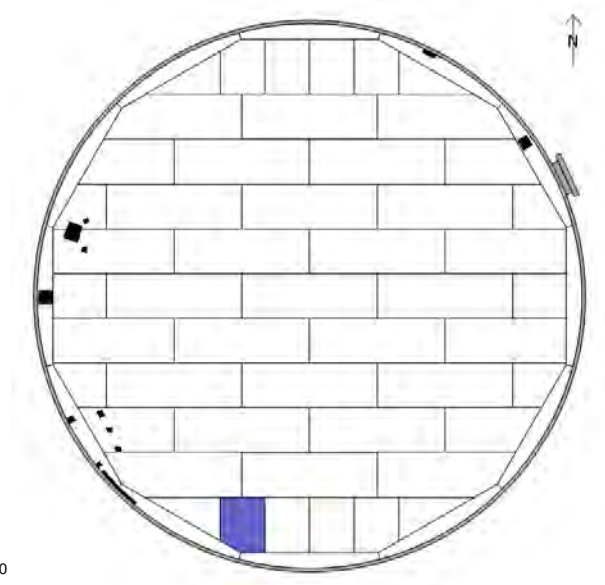
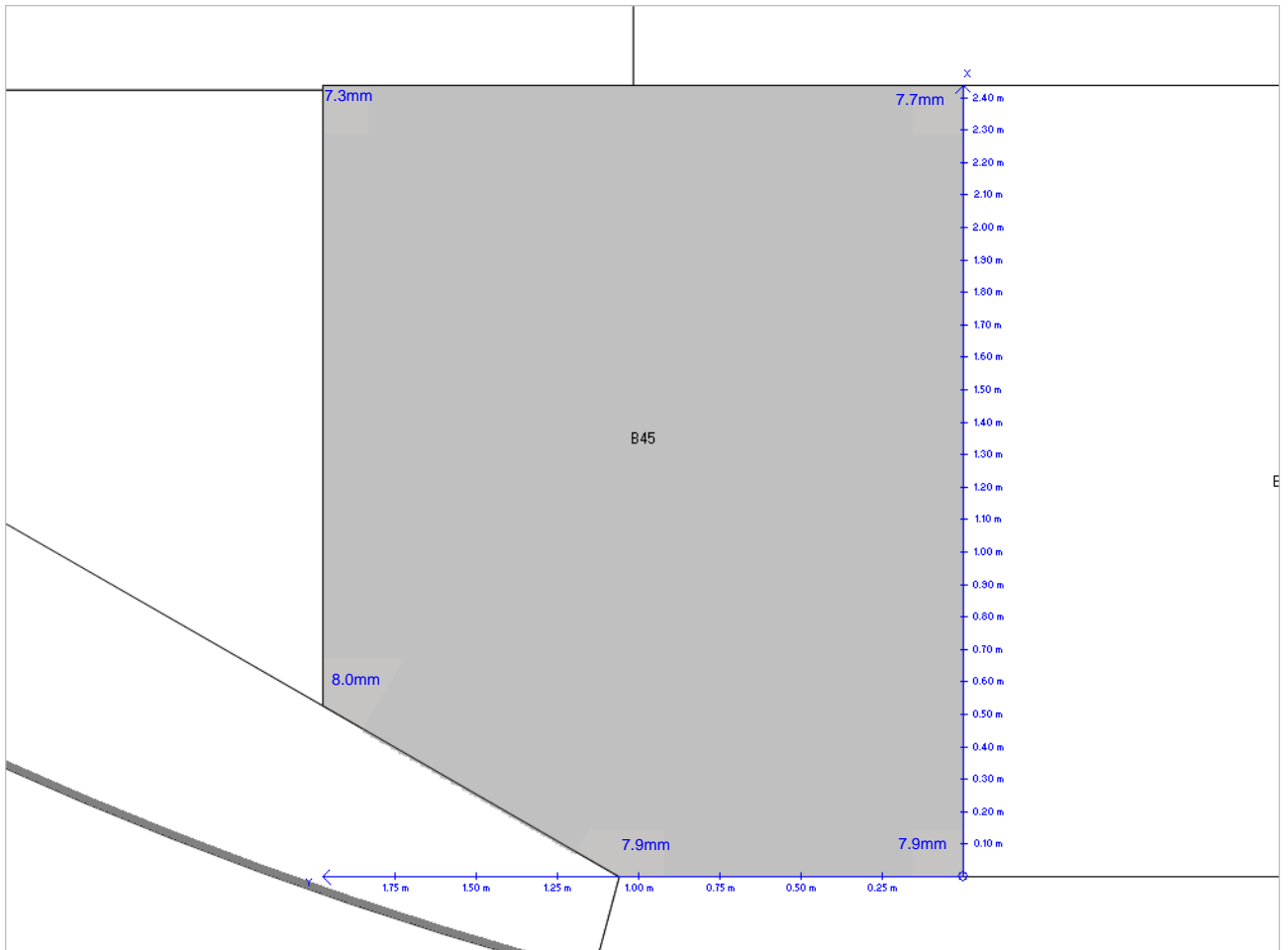

: Client a : Site b : 03/05/2016 : B 46	: Tank 123 : K0xx-16 : Jxx86
--	------------------------------------

Ultrasonic Thickness Readings

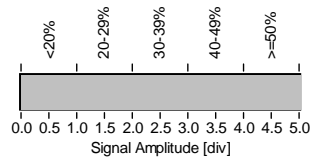
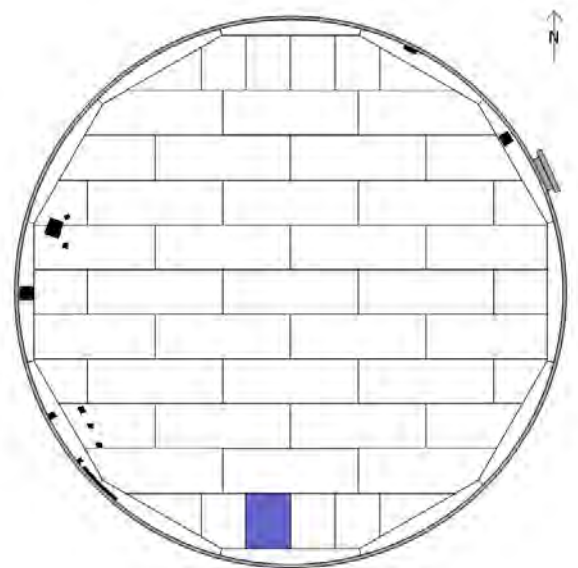
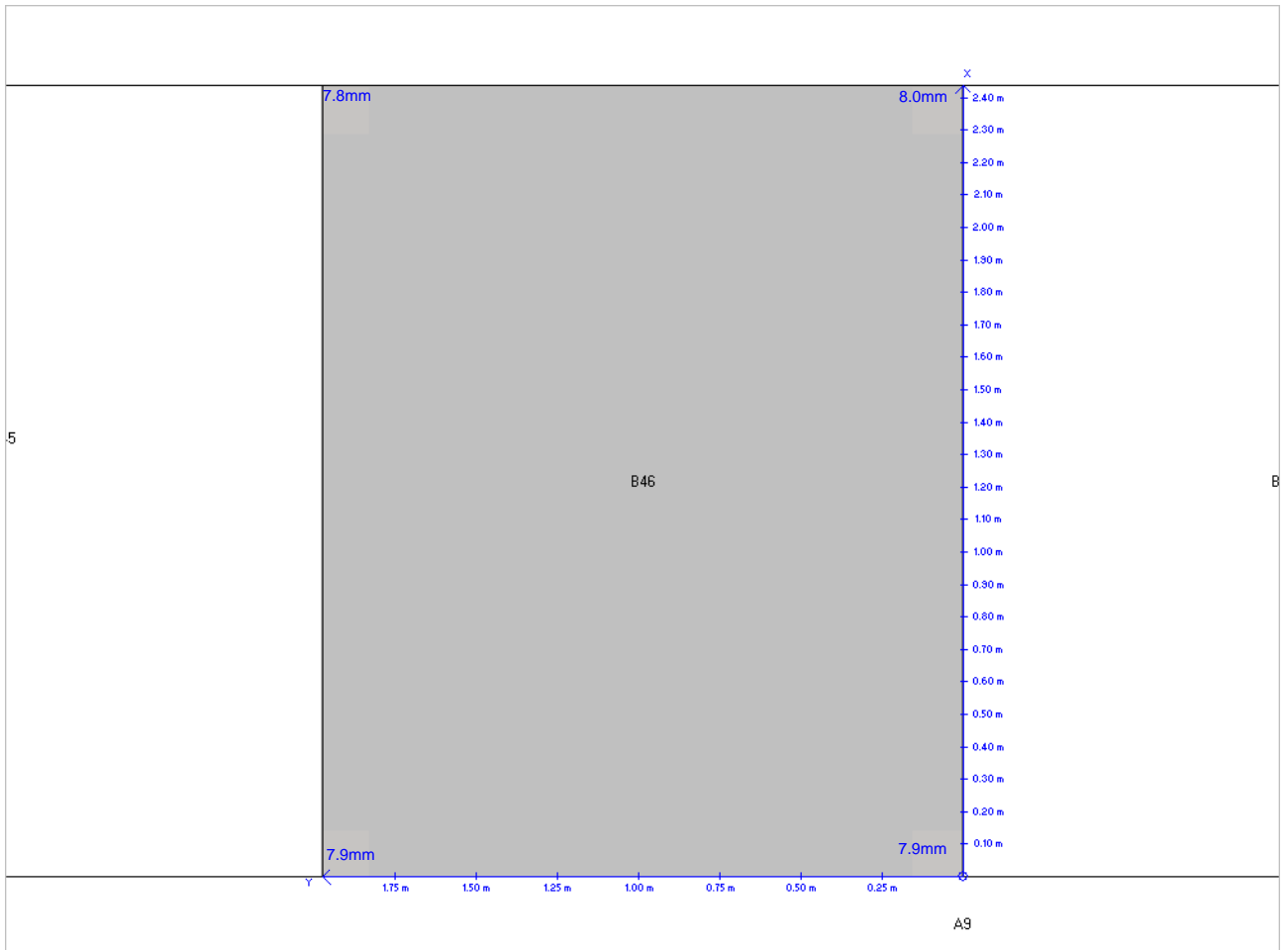

: Client a : Site b : 03/05/2016 : B 47	: Tank 123 : K0xx-16 : Jxx86
--	------------------------------------

Ultrasonic Thickness Readings

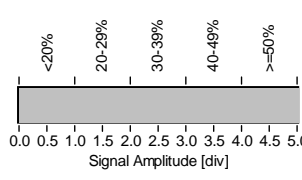
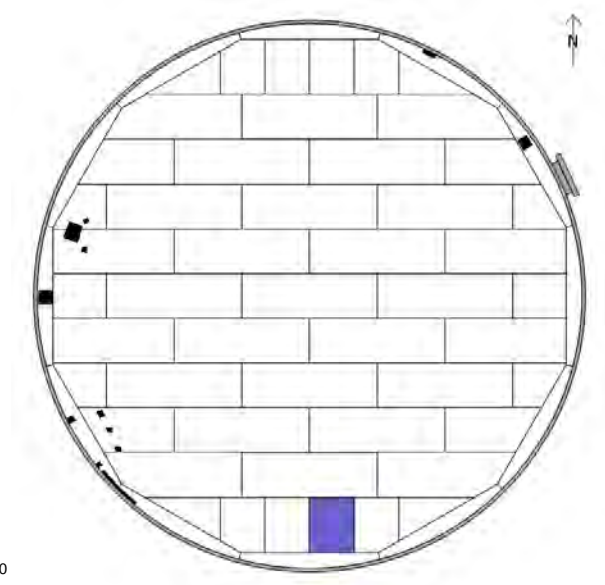
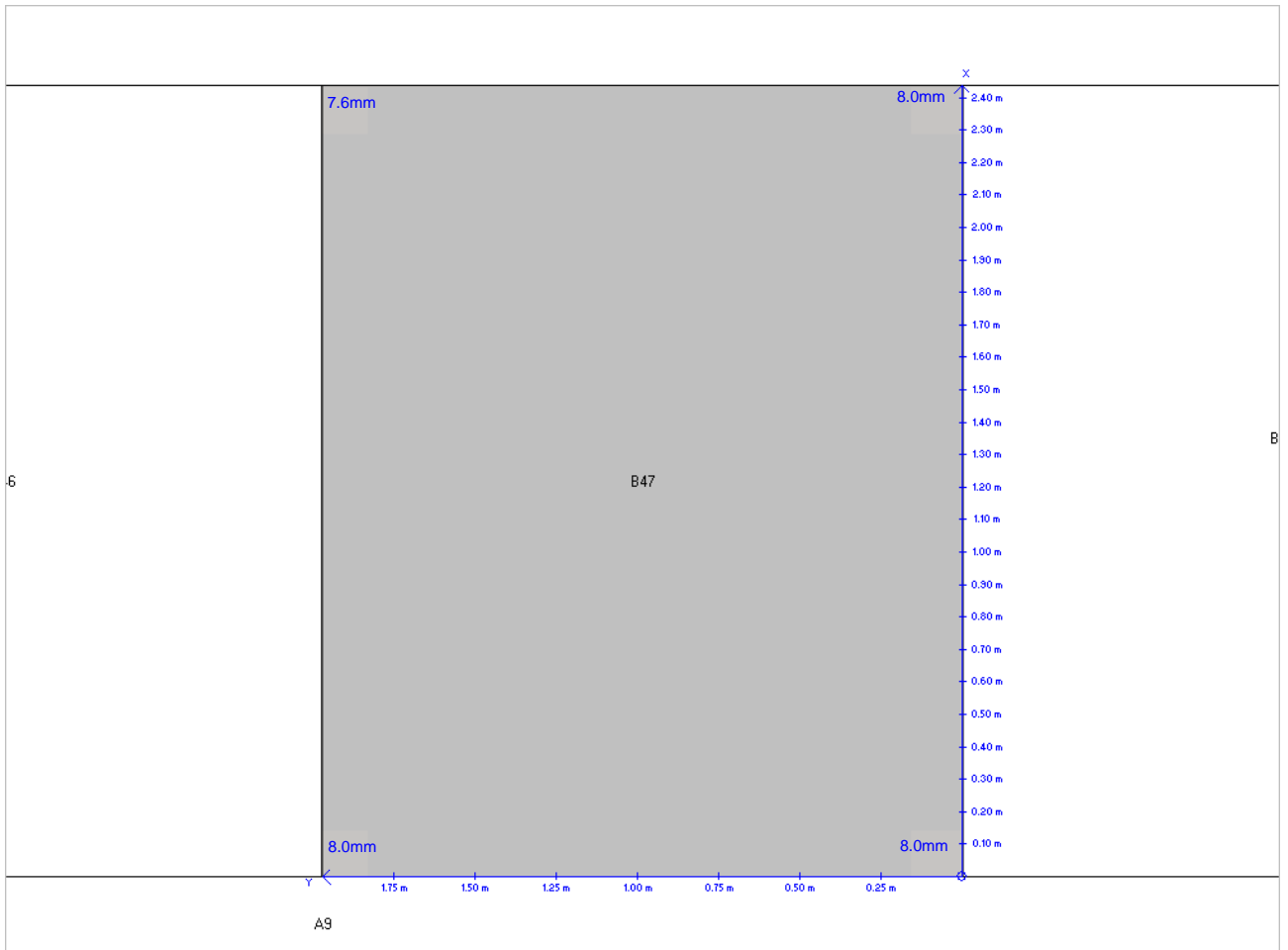

<ul style="list-style-type: none"> : Client a : Site b : 03/05/2016 : B 48 	<ul style="list-style-type: none"> : Tank 123 : K0xx-16 : Jxx86
--	--

Ultrasonic Thickness Readings

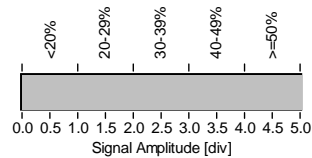
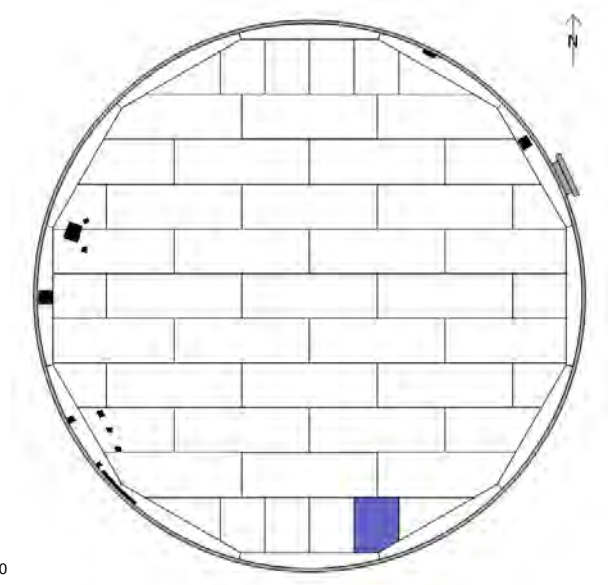
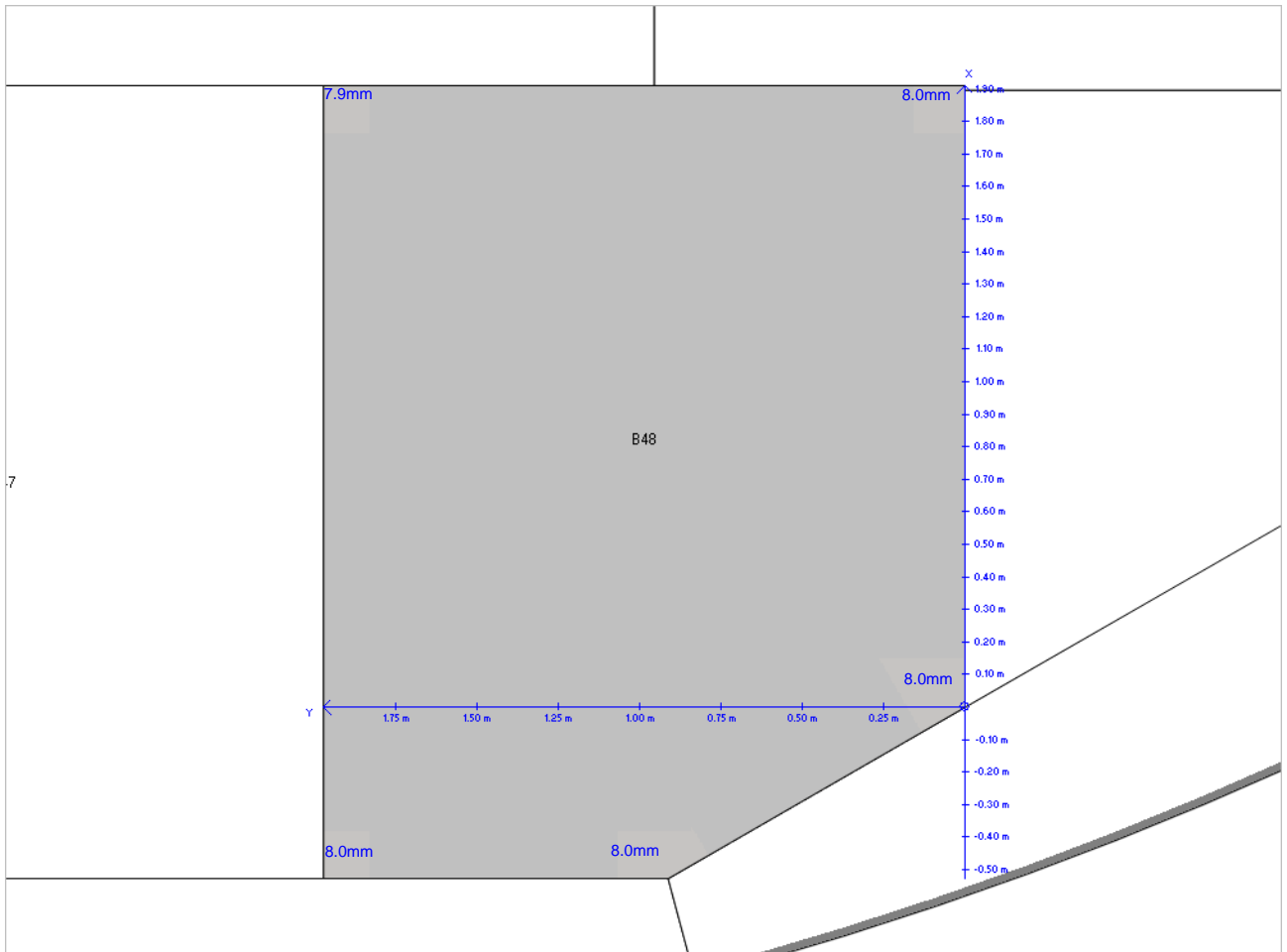

<ul style="list-style-type: none"> : Client a : Site b : 03/05/2016 : B 49 	<ul style="list-style-type: none"> : Tank 123 : K0xx-16 : Jxx86
--	--

Ultrasonic Thickness Readings

