

Unit 27/28  
Webb Ellis Park  
Rugby CV21 2NP  
Warwickshire, UK  
Phone: +44 (0) 1788 5472 94  
Fax: +44 (0) 1788 5472 99

Howemoss Avenue - Unit 1  
Kirkhill Industrial  
Dyce AB21 0GP  
Aberdeen, UK  
Phone: +44 (0) 1224 724 744  
Fax: +44 (0) 1224 774 087



[WWW.INNOSPECTION.COM](http://WWW.INNOSPECTION.COM)

[INFO@INNOSPECTION.COM](mailto:INFO@INNOSPECTION.COM)



## Report Content

	Page
1.0 Test Object	2
2.0 Inspection Task	2
3.0 Test Equipment	2
4.0 Scanner Movement	2
5.0 Instrument Settings & Calibration	3
6.0 Inspection Results Summery	3
7.0 Documentation Storage	3



## 1.0 Test Object

Item	:	30" Cell Fill Lines and Dead Legs
Material	:	Carbon Steel
Scans	:	Longitudinal
Surface Condition	:	Coated

## 2.0 Inspection Task

As per instructed a SLOFEC™ - (Saturation Low Frequency Eddy Current) inspection was carried out on the 30" Cell Fill Lines and Dead Leg Manifold

The inspection was performed with a SLOFEC™ technology scanner. This method of testing makes it practical to inspect the pipe from the external surface whilst still in service and at operating temperature.

Purpose of the inspection was to detect General Internal Corrosion.

## 3.0 Test Equipment

### SLOFEC™ Equipment and Accessories

The inspection system consists of:

Eddy current instrument:	IBM-AT-compatible computer with 2-frequency eddy current plug-in cards, type EddyMax.
SLOFEC™ LS 150D:	The SLOFEC™ Scanner is a handheld system consisting of an electromagnetic coil and multiplexed electronics. 8 Sensors with a width of 15mm each are located between the pole shoes. A trigger encoder is connected. 2 wheels at the front and 2 wheels at the rear are adjustable in height for lift off alteration.
Cable	Specific cable connection between computer eddy current Instrument and SLOFEC™ Pipe Scanner LS 150D is 30m in length.
Database system:	EddyMax eddy current multiplexes software
	With trigger use: SN 20000997 TMT
	Version: 5.07.07.20

## 4.0 Scanner Movement

The scanner assistant, who was in permanent communication with the SLOFEC™ operator, is responsible for the positioning of the scanner on the pipe surface. SLOFEC™ Pipe Scanner LS 150D is marked on the top with FORWARD and BACKWARD direction, so that all scan directions are made clear between operators and assistant.



## 5.0 Instrument Settings and Calibration

The Frequency setting used for channel's 1-8 (Differential Mode) – 100Khz.

The differential channel of all sensors was set so that defects are indicated in the vertical signal phase direction. Moving the scanner in a positive forward direction, the defect signal had the first peak down followed by an upward direction of the second peak.

The amplitude of the signals was set so that the artificial reference defect (Ø 10mm 60% depth) was set at full screen height peak to peak.

### Note:-

1/ Eddy Current inspection is an evaluation method of Non-Destructive Testing.

All settings and results obtained are based on the test piece material and relevant artificial defects used.

2/ The Sensitivity used for this test is designed to locate internal pitting and general corrosion.

## 6.0 Summary of Inspection Results

Pipe Identification	Section	% Wall Loss
P-161	Vertical Section No'1 BGTF	<10%
P-161	Vertical Section No'2 BGTF	<10%
P-161	Vertical Section No'3 BGTF	<10%
P-161	Vertical Section No'4 BGTF	<10%
P-162	Vertical Section No'1 BGTF	<10%
P-162	Vertical Section No'2 BGTF	<10%
P-162	Vertical Section No'3 BGTF	<10%
P-163	Vertical Section No'1 BGTF	<10%
P-163	Vertical Section No'2 BGTF	<10%
P-163	Vertical Section No'3 BGTF	<10%
P-163	Vertical Section No'4 BGTF	<10%



See attached sheets for indication locations.

**7.0 Documentation**

This inspection report is stored on disk in the Innospection documentation system.



Innospection Limited (SLOFEC Engineer)

Mr M.Woolridge.



**30" P-161 Section 1**

The BMP image below shows the results obtained from SLOFEC scans numbered 1 to 19 on the vertical section starting with track 1 facing Rig North and the following tracks produced in an anti-clockwise direction looking down the Pipe.

Track 1 ← Circumferential Windup → Track 19

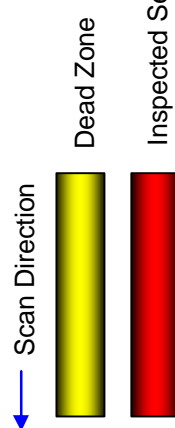
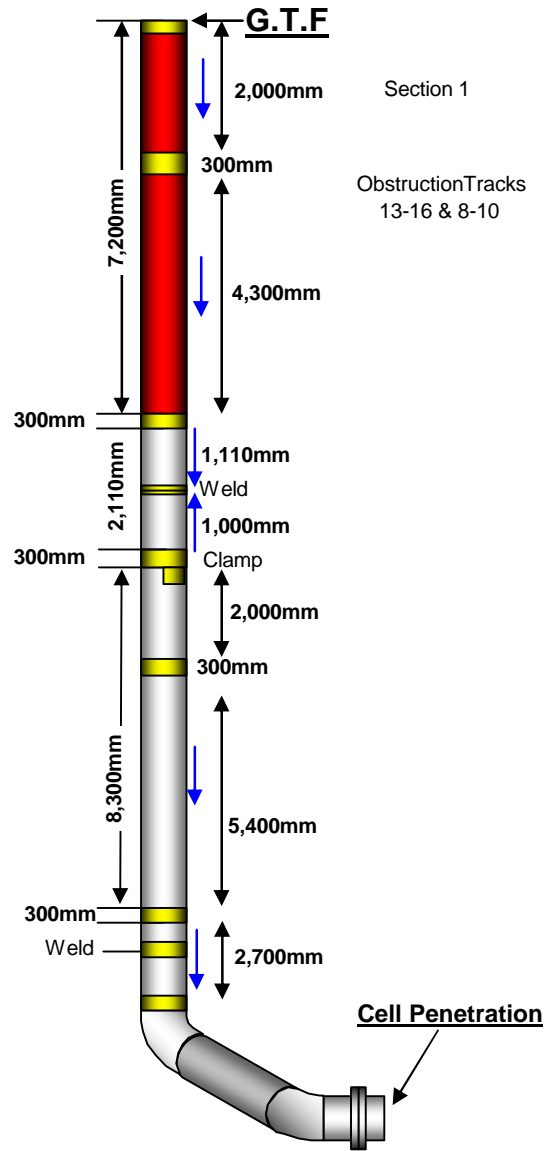

**Remarks**  
 The BMP images are a representation of the area accessible by the SLOFEC™ scanner. The images also show (if any) the presence of internal indications proportional in depth to the colour chart above.

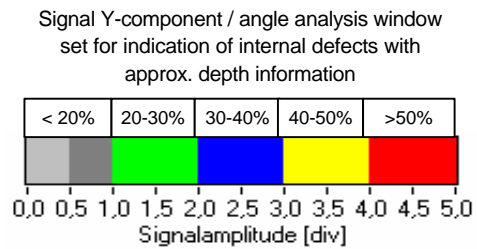

Client	: Shell Expro
Location	: Brent Charlie
Pipe Ident	: P-161
Pipe Diameter	: 30"
Date	: 28/03/2008
K-No.	: 434-07

**30" P-161 Section 2**

The BMP image below shows the results obtained from SLOFEC scans numbered 1 to 19 on the vertical section starting with track 1 facing Rig North and the following tracks produced in an anti-clockwise direction looking down the Pipe.

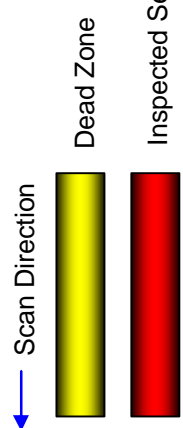
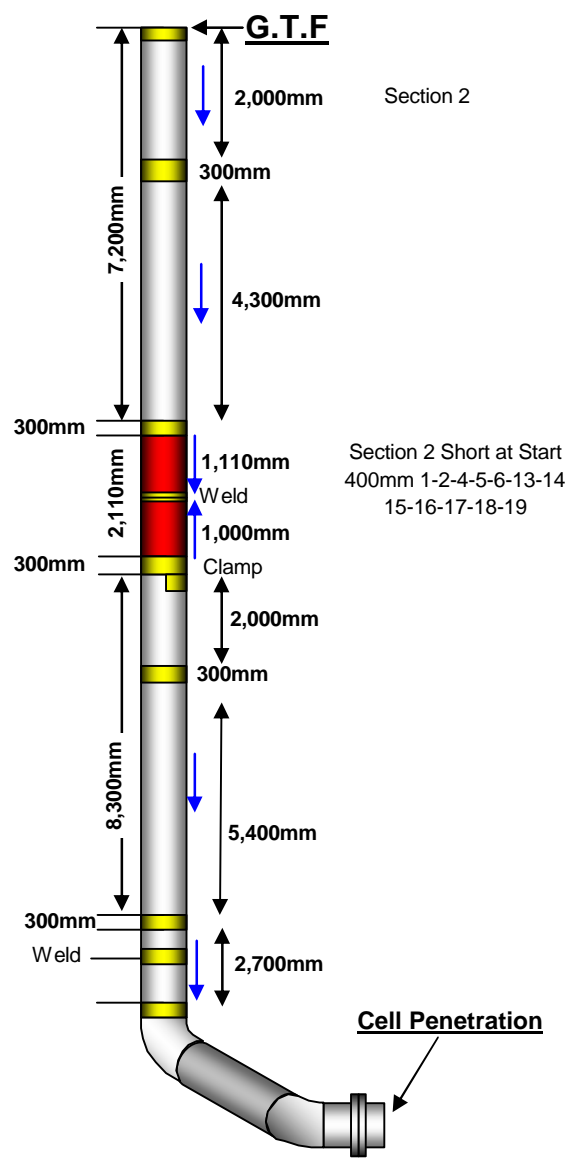
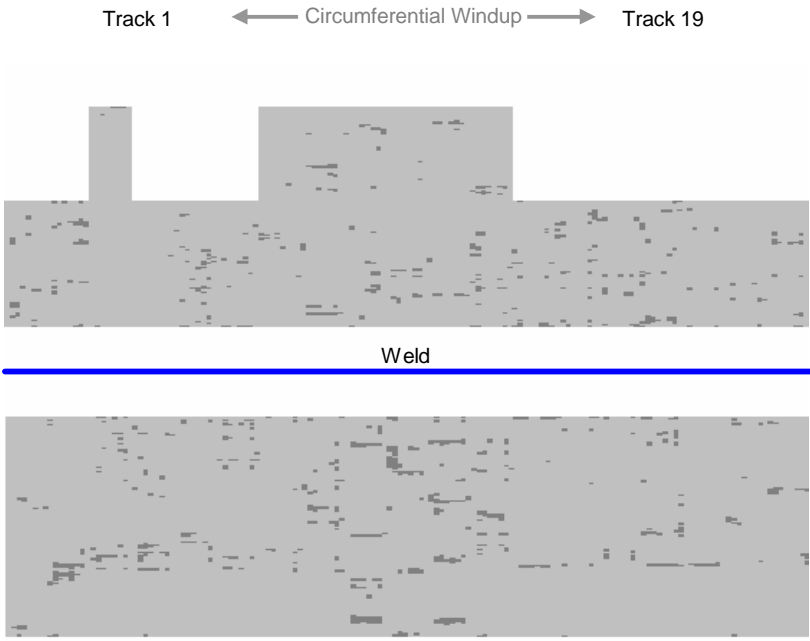

**Remarks**  
 The BMP images are a representation of the area accessible by the SLOFEC™ scanner. The images also show (if any) the presence of internal indications proportional in depth to the colour chart above.

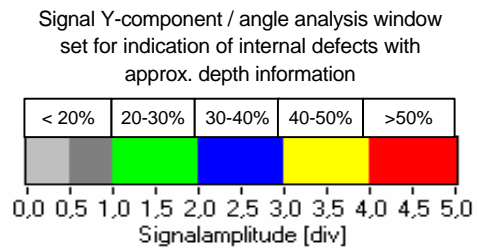

Client	: Shell Expro
Location	: Brent Charlie
Pipe Ident	: P-161
Pipe Diameter	: 30"
Date	: 28/03/2008
K-No.	: 434-07

**30" P-161 Section 3**

The BMP image below shows the results obtained from SLOFEC scans numbered 1 to 19 on the vertical section starting with track 1 facing Rig North and the following tracks produced in an anti-clockwise direction looking down the Pipe.

Track 1 ← Circumferential Windup → Track 19

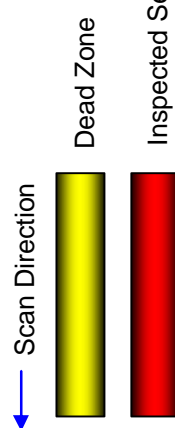
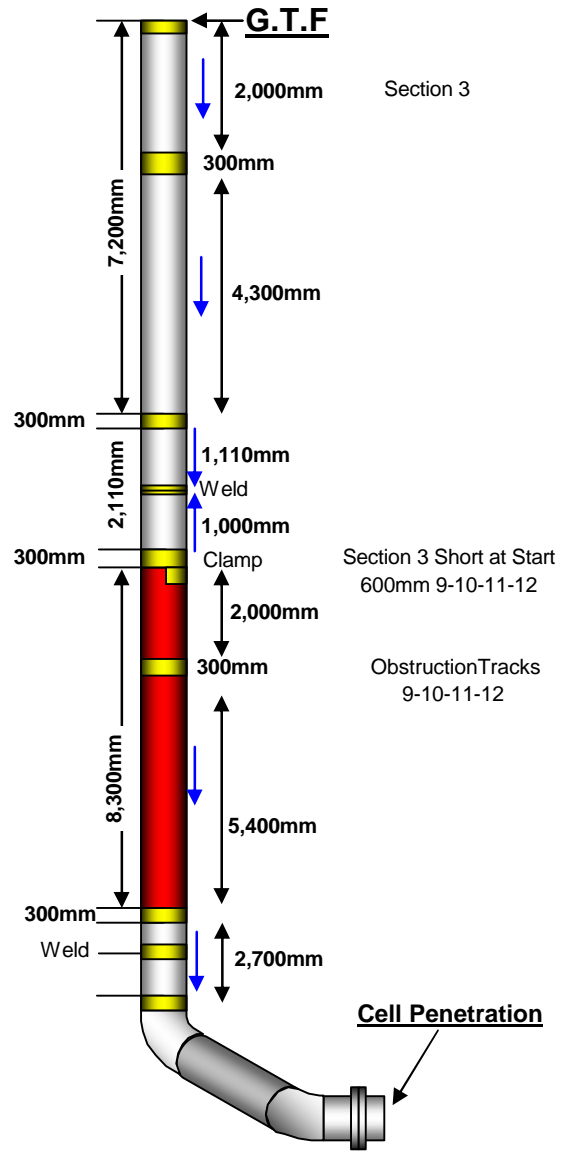

**Remarks**  
 The BMP images are a representation of the area accessible by the SLOFEC™ scanner. The images also show (if any) the presence of internal indications proportional in depth to the colour chart above.

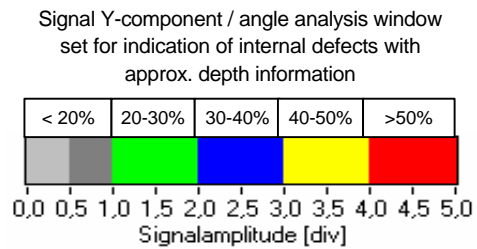

Client	: Shell Expro
Location	: Brent Charlie
Pipe Ident	: P-161
Pipe Diameter	: 30"
Date	: 28/03/2008
K-No.	: 434-07

**30" P-161 Section 4**

The BMP image below shows the results obtained from SLOFEC scans numbered 1 to 19 on the vertical section starting with track 1 facing Rig North and the following tracks produced in an anti-clockwise direction looking down the Pipe.

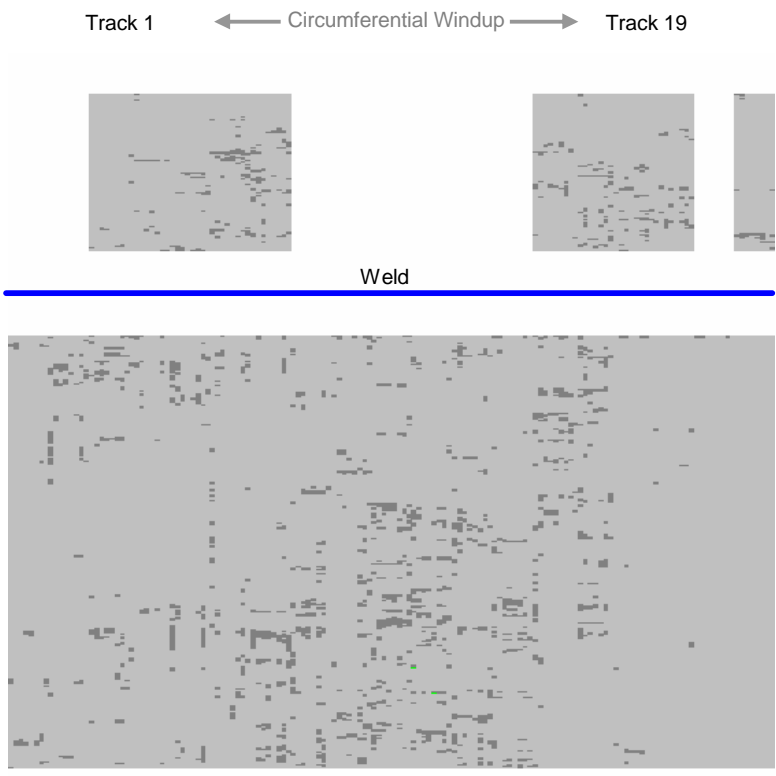
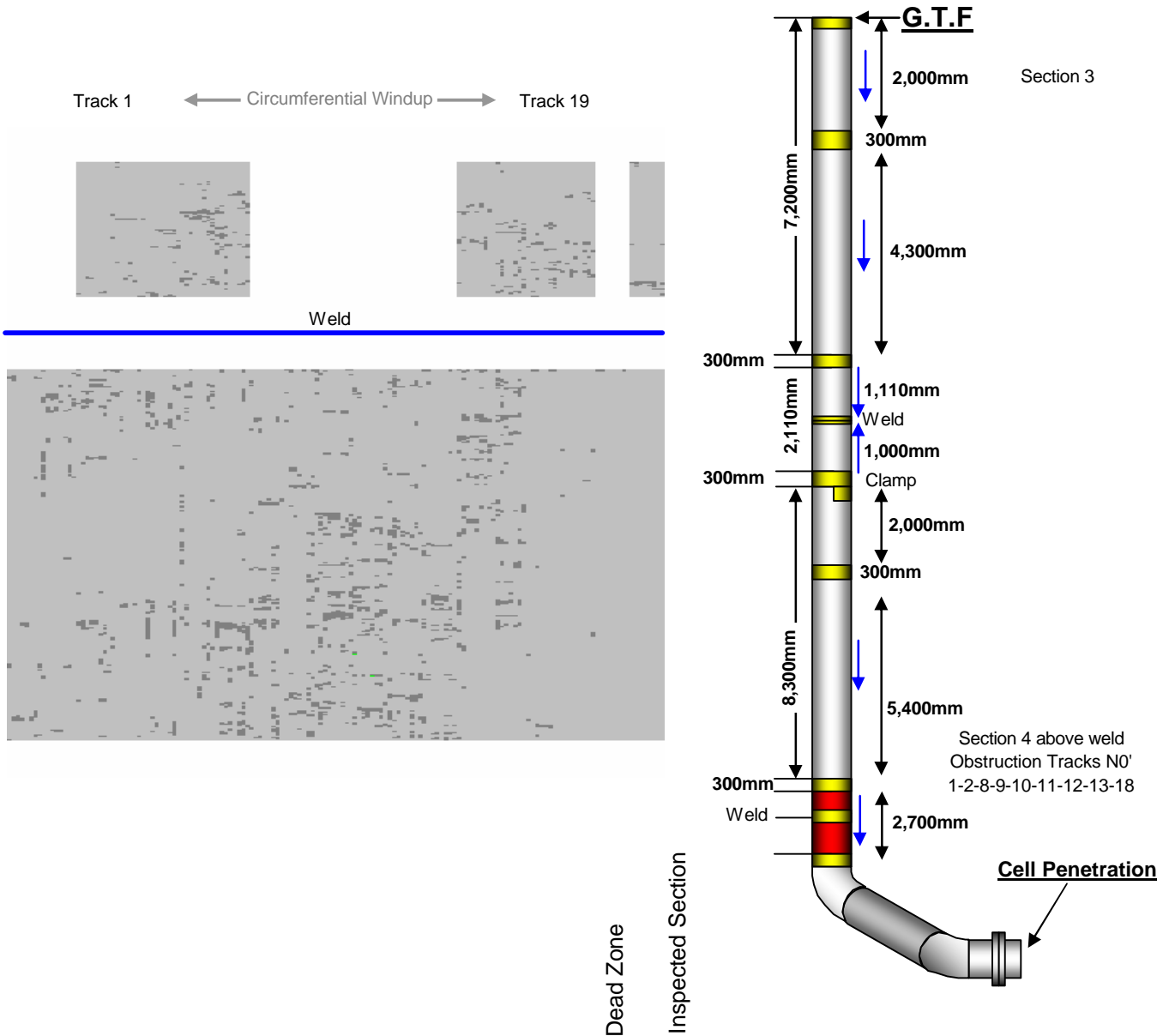

**Scan Direction** ↓

**Dead Zone** (Yellow bar)

**Inspected Section** (Red bar)

**Remarks**  
 The BMP images are a representation of the area accessible by the SLOFEC™ scanner. The images also show (if any) the presence of internal indications proportional in depth to the colour chart above.

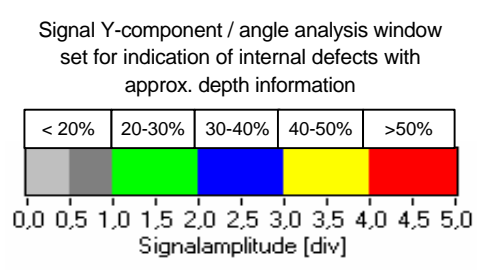

Client	: Shell Expro
Location	: Brent Charlie
Pipe Ident	: P-161
Pipe Diameter	: 30"
Date	: 28/03/2008
K-No.	: 434-07

**30" P-162 Section 1**

The BMP image below shows the results obtained from SLOFEC scans numbered 1 to 19 on the vertical section starting with track 1 facing Rig North and the following tracks produced in an anti-clockwise direction looking down the Pipe.

Track 1 ← Circumferential Windup → Track 19

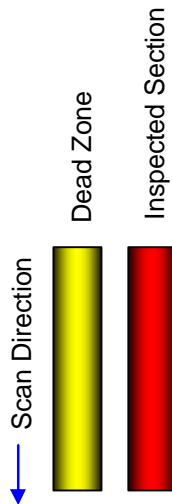
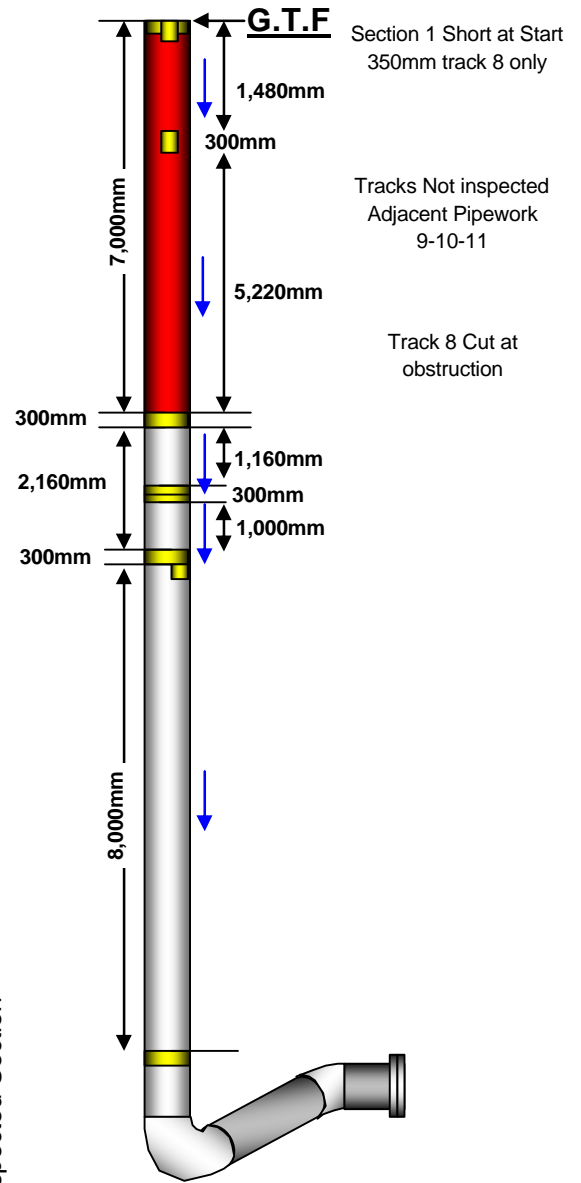
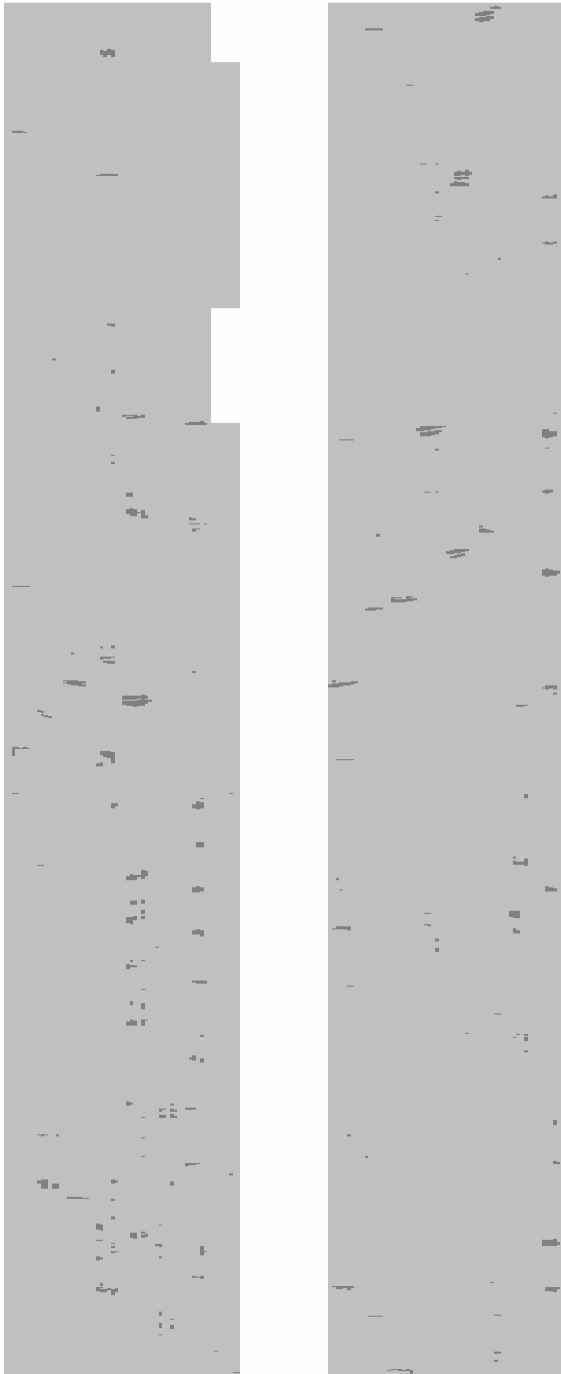

**Remarks**

The BMP images are a representation of the area accessible by the SLOFEC™ scanner. The images also show (if any) the presence of internal indications proportional in depth to the colour chart above.

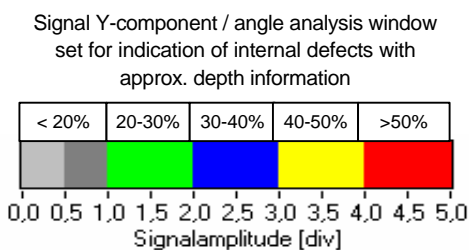

Client	: Shell Expro
Location	: Brent Charlie
Pipe Ident	: P-162
Pipe Diameter	: 30"
Date	: 28/03/2008
K-No.	: 434-07

**30" P-162 Section 2**

The BMP image below shows the results obtained from SLOFEC scans numbered 1 to 19 on the vertical section starting with track 1 facing Rig North and the following tracks produced in an anti-clockwise direction looking down the Pipe.

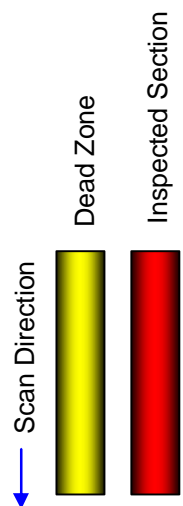
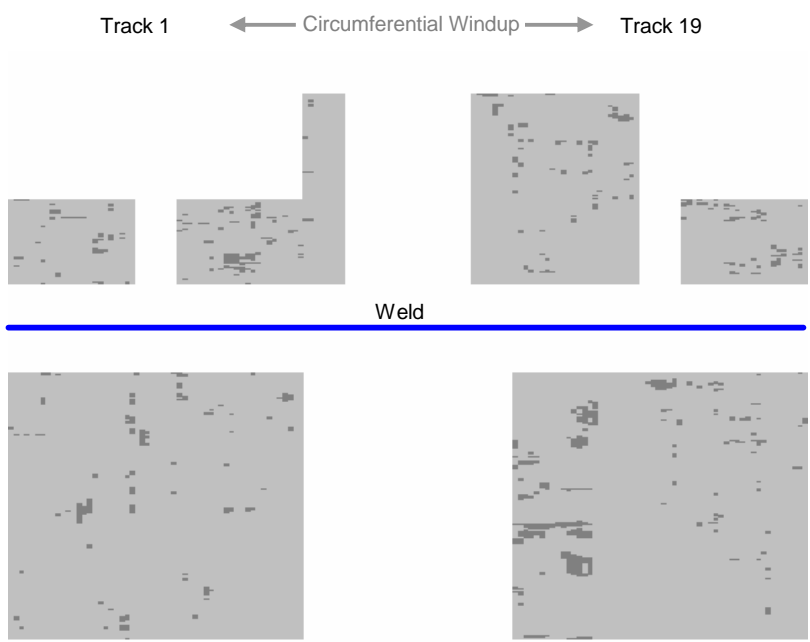
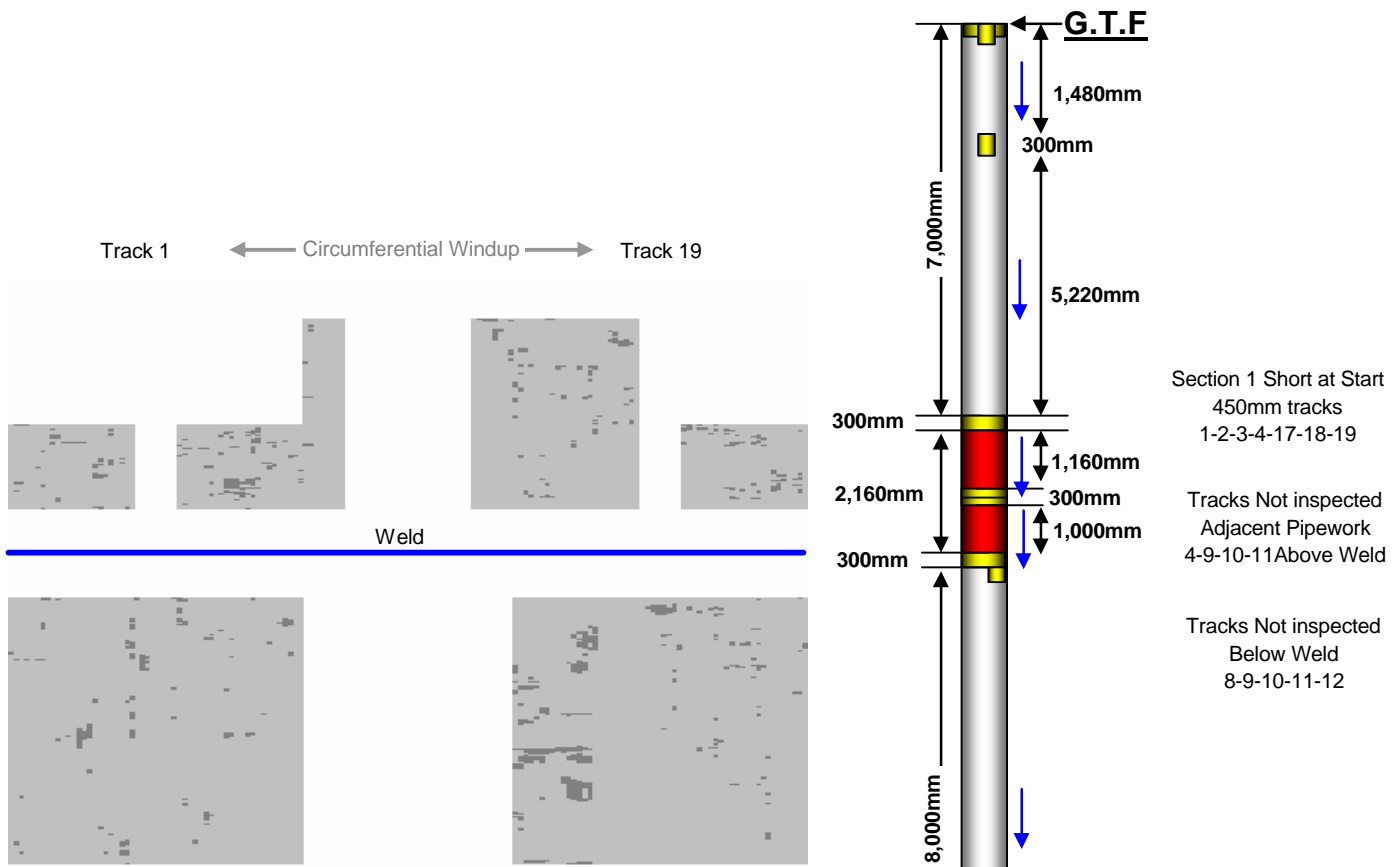

**Remarks**  
 The BMP images are a representation of the area accessible by the SLOFEC™ scanner. The images also show (if any) the presence of internal indications proportional in depth to the colour chart above.

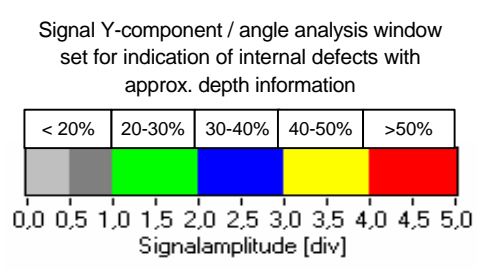

Client	: Shell Expro
Location	: Brent Charlie
Pipe Ident	: P-162
Pipe Diameter	: 30"
Date	: 28/03/2008
K-No.	: 434-07

**30" P-162 Section 3**

The BMP image below shows the results obtained from SLOFEC scans numbered 1 to 19 on the vertical section starting with track 1 facing Rig North and the following tracks produced in an anti-clockwise direction looking down the Pipe.

Track 1 ← Circumferential Windup → Track 19

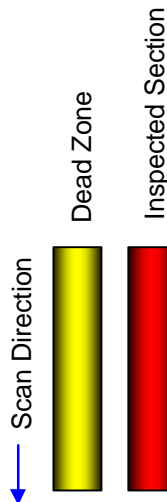
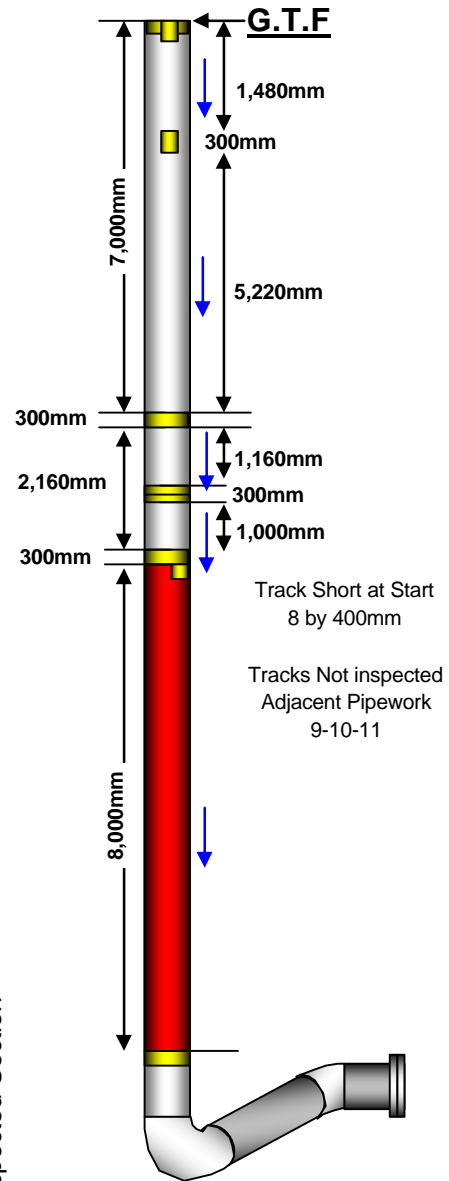
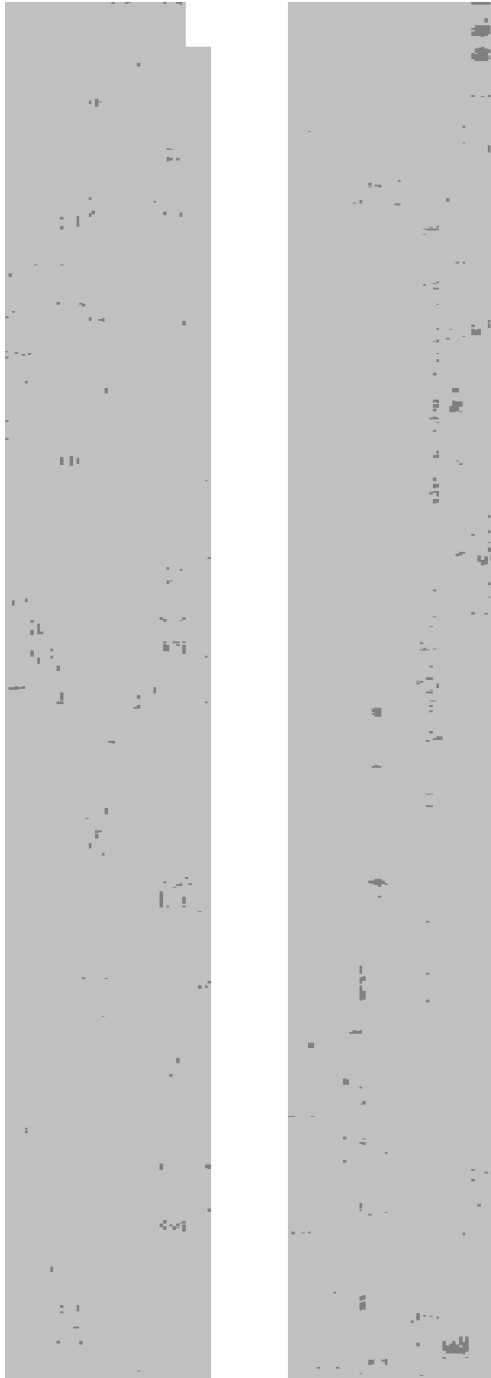

**Remarks**

The BMP images are a representation of the area accessible by the SLOFEC™ scanner. The images also show (if any) the presence of internal indications proportional in depth to the colour chart above.

Signal Y-component / angle analysis window set for indication of internal defects with approx. depth information

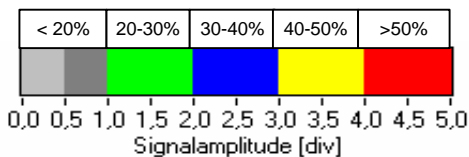

Client	:	Shell Expro
Location	:	Brent Charlie
Pipe Ident	:	P-162
Pipe Diameter	:	30"
Date	:	28/03/2008
K-No.	:	434-07

**30" P-163 Section 1**

The BMP image below shows the results obtained from SLOFEC scans numbered 1 to 19 on the vertical section starting with track 1 facing Rig North and the following tracks produced in an anti-clockwise direction looking down the Pipe.

Track 1 ← Circumferential Windup → Track 19

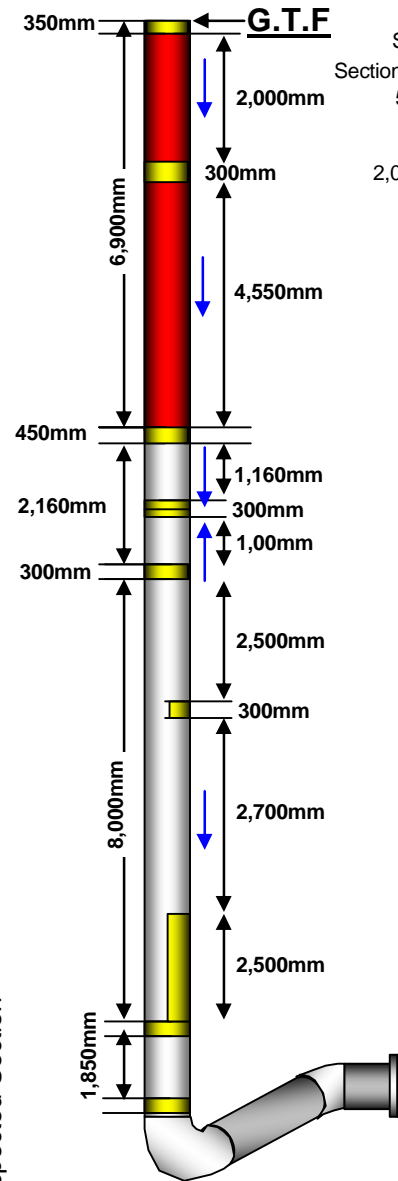
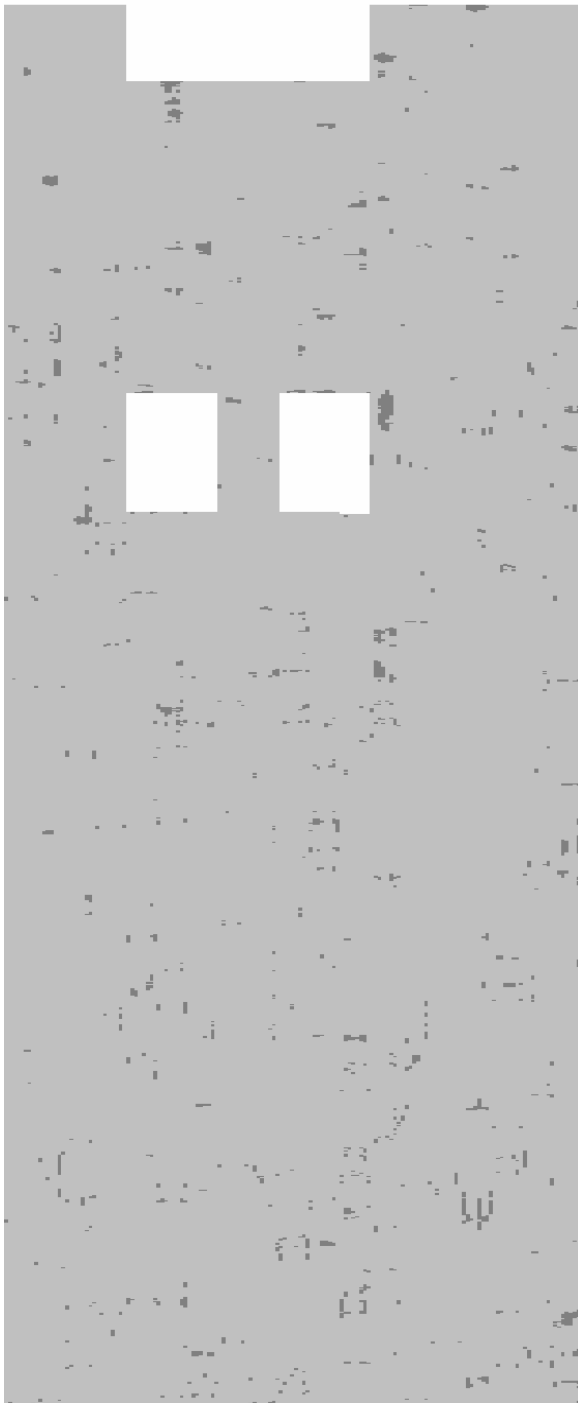

Section 1  
Section 1 Short at Start  
5-6-10-11  
2,000mm tracks  
5-6-10-11



**Remarks**

The BMP images are a representation of the area accessible by the SLOFEC™ scanner. The images also show (if any) the presence of internal indications proportional in depth to the colour chart above.

Signal Y-component / angle analysis window set for indication of internal defects with approx. depth information

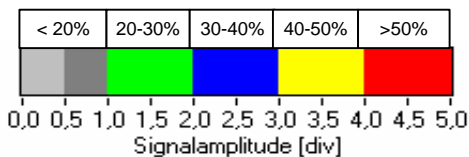

Client : Shell Expro  
Location : Brent Charlie  
Pipe Ident : P-163  
Pipe Diameter : 30"  
Date : 28/03/2008  
K-No. : 434-07

**30" P-163 Section 2**

The BMP image below shows the results obtained from SLOFEC scans numbered 1 to 19 on the vertical section starting with track 1 facing Rig North and the following tracks produced in an anti-clockwise direction looking down the Pipe.

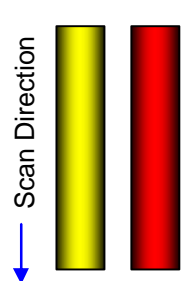
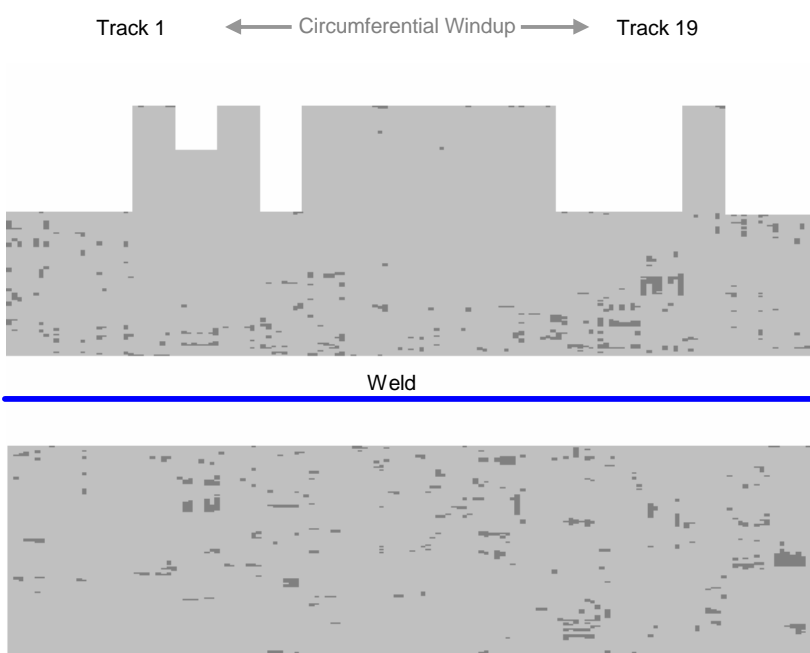
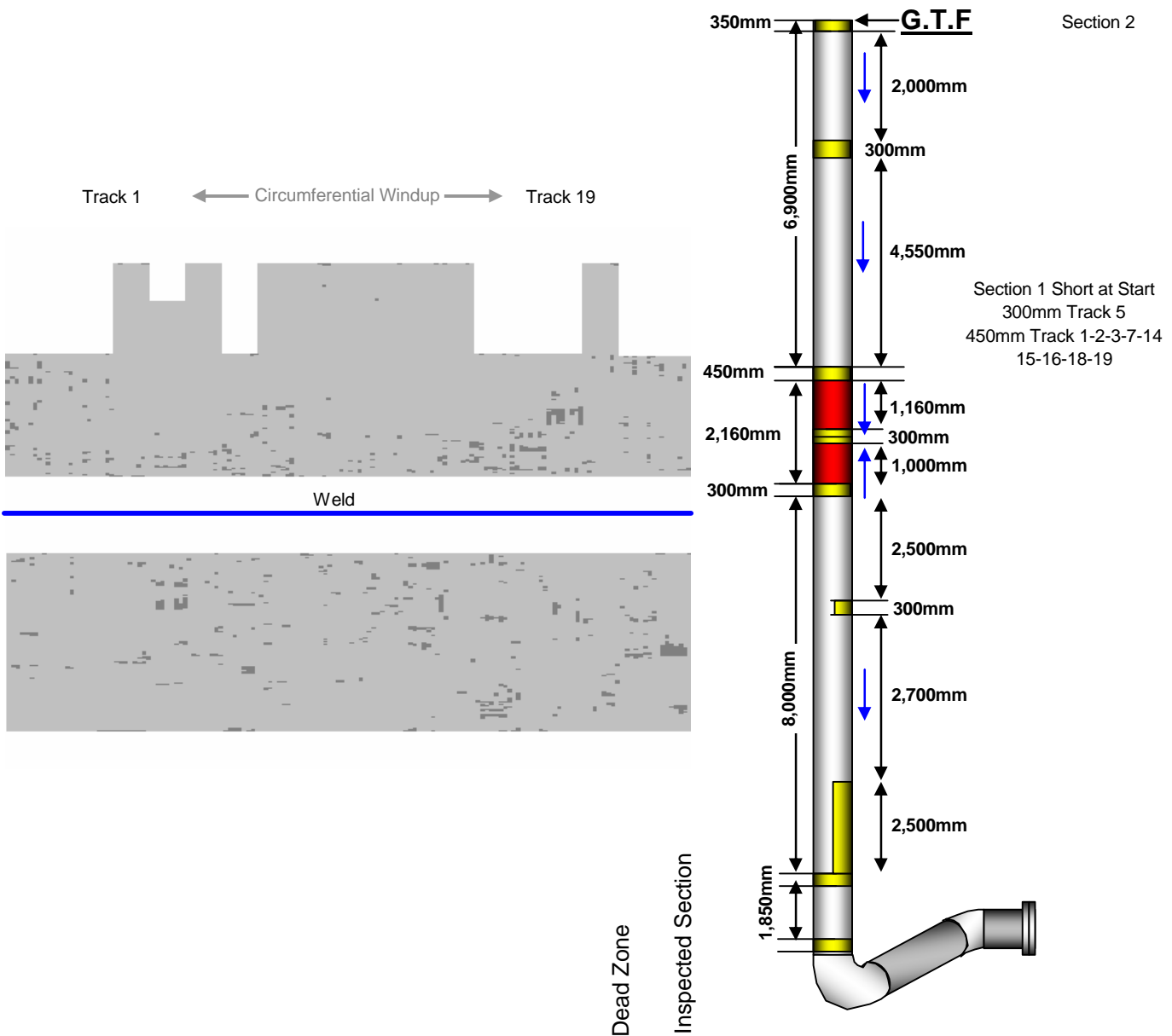

**Remarks**  
 The BMP images are a representation of the area accessible by the SLOFEC™ scanner. The images also show (if any) the presence of internal indications proportional in depth to the colour chart above.

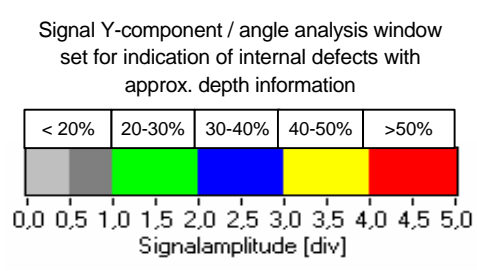

Client	: Shell Expro
Location	: Brent Charlie
Pipe Ident	: P-163
Pipe Diameter	: 30"
Date	: 28/03/2008
K-No.	: 434-07

**30" P-163 Section 3**

The BMP image below shows the results obtained from SLOFEC scans numbered 1 to 19 on the vertical section starting with track 1 facing Rig North and the following tracks produced in an anti-clockwise direction looking down the Pipe.

Track 1 ← Circumferential Windup → Track 19

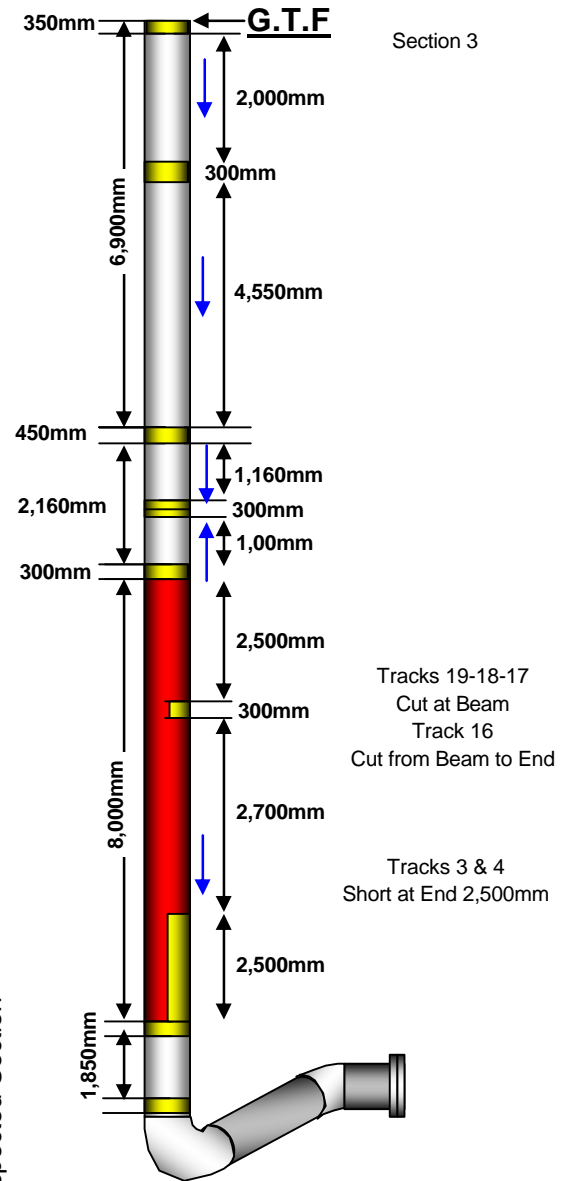
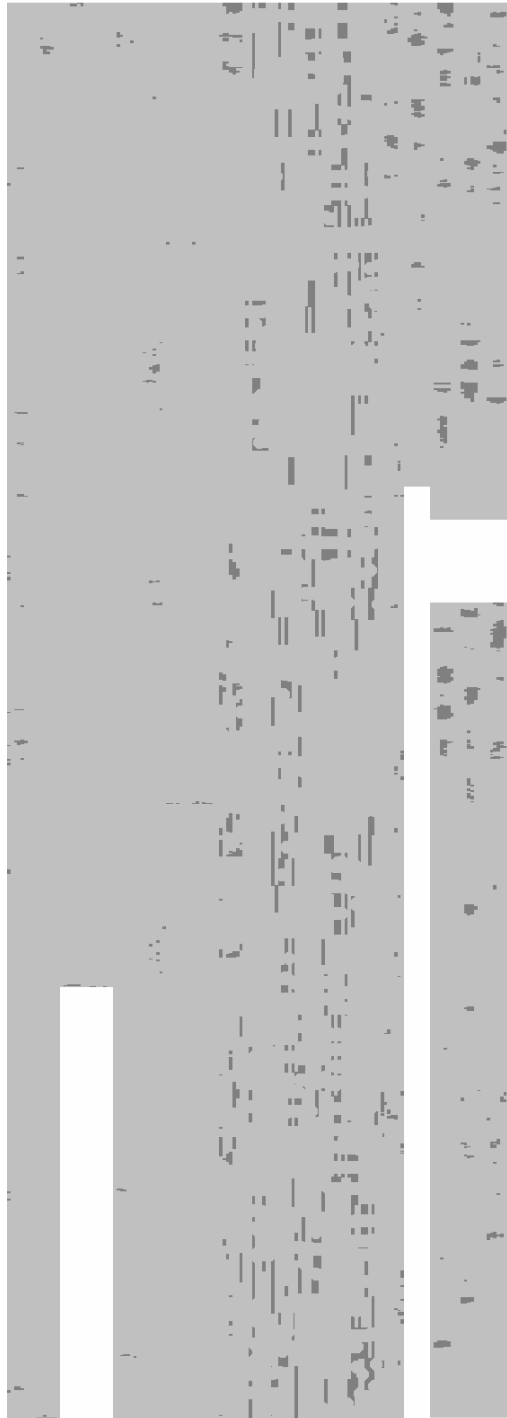

**Remarks**

The BMP images are a representation of the area accessible by the SLOFEC™ scanner. The images also show (if any) the presence of internal indications proportional in depth to the colour chart above.

Signal Y-component / angle analysis window set for indication of internal defects with approx. depth information

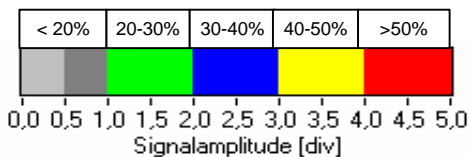

Client	: Shell Expro
Location	: Brent Charlie
Pipe Ident	: P-163
Pipe Diameter	: 30"
Date	: 28/03/2008
K-No.	: 434-07

**30" P-163 Section 4**

The BMP image below shows the results obtained from SLOFEC scans numbered 1 to 19 on the vertical section starting with track 1 facing Rig North and the following tracks produced in an anti-clockwise direction looking down the Pipe.

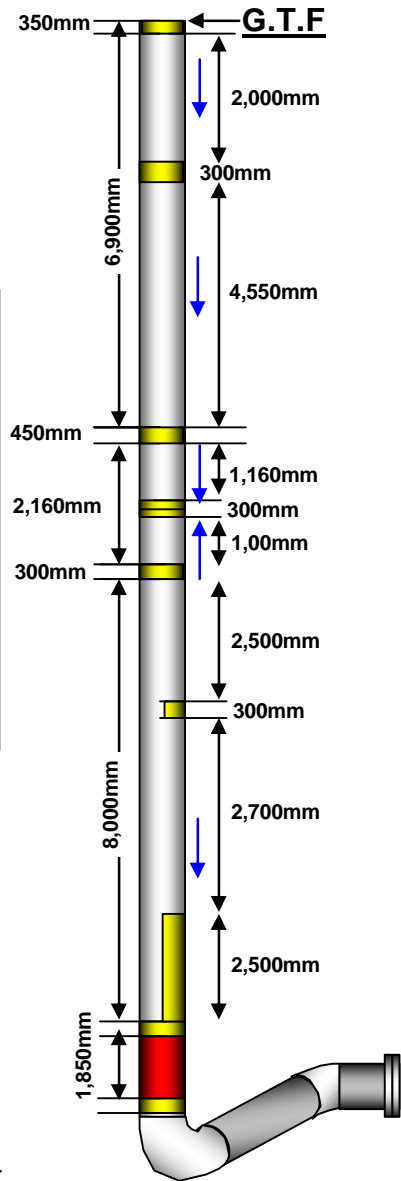
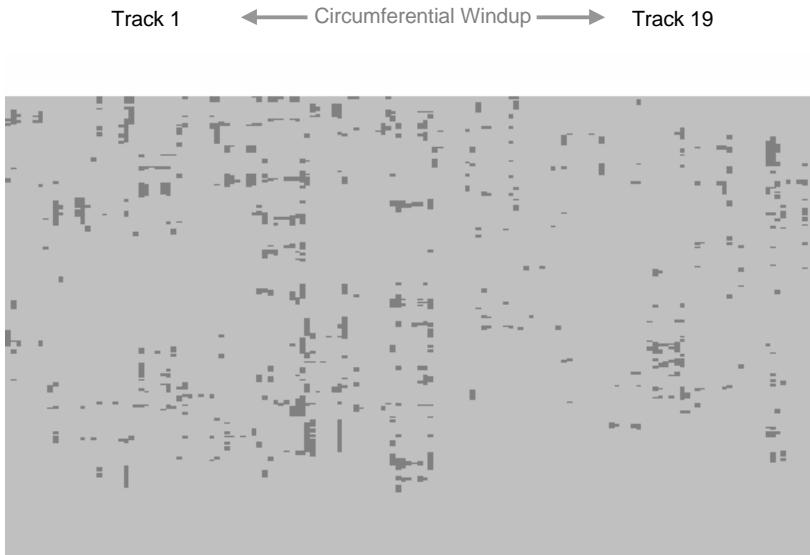

Section 4



**Remarks**

The BMP images are a representation of the area accessible by the SLOFEC™ scanner. The images also show (if any) the presence of internal indications proportional in depth to the colour chart above.

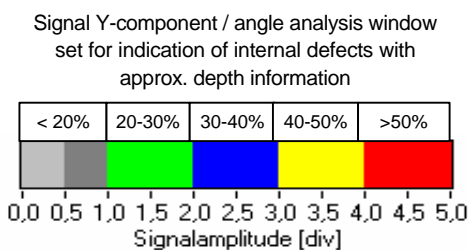

Client	:	Shell Expro
Location	:	Brent Charlie
Pipe Ident	:	P-163
Pipe Diameter	:	30"
Date	:	28/03/2008
K-No.	:	434-07



GB2000158



## INSPECTION REPORT

# SLOFEC Pipe Inspection Report

<b>Client</b>	<b>Shell Expro</b>
<b>Items Inspected</b>	<b>P-160, P-161, P-162, P-163 Horizontal Sections Below G.T.F. C4</b>
<b>Platform</b>	<b>Brent Charlie</b>
<b>Inspection Method</b>	<b>SLOFEC™</b>
<b>Date Commenced</b>	<b>07/11/07</b>
<b>Report Completed</b>	<b>21/11/07</b>
<b>Type of Report</b>	<b>Final Inspection Report</b>
<b>Report Number</b>	<b>K-Nr 434-07</b>

### Aberdeen Office

Unit 1 Howemoss Avenue  
Kirkhill Industrial Estate  
Dyce  
Aberdeen  
AB21 0GP  
United Kingdom  
Phone: +44 (0) 1224 724 744  
Fax: +44 (0) 1224 774 087  
Web Address:  
E-Mail:

### Rugby Office

Unit 27  
Webb Ellis Industrial Park  
Rugby  
Warwickshire  
CV21 2NP  
United Kingdom  
+44 (0) 1788 547 294  
+44 (0) 1788 547 299  
[www.innospection.com](http://www.innospection.com)  
[info@innospection.com](mailto:info@innospection.com)





## Report Content

	Page
1.0 Test Object	2
2.0 Inspection Task	2
3.0 Test Equipment	2
4.0 Scanner Movement	2
5.0 Instrument Settings & Calibration	3
6.0 Inspection Results	3
7.0 Documentation Storage	3



## 1.0 Test Object

Item	:	30" Cell Fill Lines and Dead Legs
Material	:	Carbon Steel
Scans	:	Longitudinal
Surface Condition	:	Coated

## 2.0 Inspection Task

As per instructed a SLOFEC™ - (Saturation Low Frequency Eddy Current) inspection was carried out on the 30" Cell Fill Lines and Dead Leg Manifold

The inspection was performed with a SLOFEC™ technology scanner. This method of testing makes it practical to inspect the pipe from the external surface whilst still in service and at operating temperature.

Purpose of the inspection was to detect General Internal Corrosion.

## 3.0 Test Equipment

### SLOFEC™ Equipment and Accessories

The inspection system consists of:

Eddy current instrument:	IBM-AT-compatible computer with 2-frequency eddy current plug-in cards, type EddyMax.
SLOFEC™ LS 150D:	The SLOFEC™ Scanner is a handheld system consisting of an electromagnetic coil and multiplexed electronics. 8 Sensors with a width of 15mm each are located between the pole shoes. A trigger encoder is connected. 2 wheels at the front and 2 wheels at the rear are adjustable in height for lift off alteration.
Cable	Specific cable connection between computer eddy current Instrument and SLOFEC™ Pipe Scanner LS 150D is 30m in length.
Database system:	EddyMax eddy current multiplexes software
	With trigger use: SN 20000997 TMT
	Version: 5.07.07.20

## 4.0 Scanner Movement

The scanner assistant, who was in permanent communication with the SLOFEC™ operator, is responsible for the positioning of the scanner on the pipe surface. SLOFEC™ Pipe Scanner LS 150D is marked on the top with FORWARD and BACKWARD direction, so that all scan directions are made clear between operators and assistant.



## 5.0 Instrument Settings and Calibration

The Frequency setting used for channel's 1-8 (Differential Mode) – 100Khz.

The differential channel of all sensors was set so that defects are indicated in the vertical signal phase direction. Moving the scanner in a positive forward direction, the defect signal had the first peak down followed by an upward direction of the second peak.

The amplitude of the signals was set so that the artificial reference defect (Ø 10mm 60% depth) was set at full screen height peak to peak.

Note:-

1/ Eddy Current inspection is an evaluation method of Non-Destructive Testing.

All settings and results obtained are based on the test piece material and relevant artificial defects used.

2/ The Sensitivity used for this test is designed to locate internal pitting and general corrosion.

## 6.0 Summary of Inspection Results

Pipe Identification	Section	% Wall Loss
P-160	Horizontal Section BGTF	<20%
P-161	Horizontal Section BGTF	>50%
P-162	Horizontal Section BGTF	30-40%
P-163	Horizontal Section BGTF	20-30%

See attached sheets for indication locations.

## 7.0 Documentation

This inspection report is stored on disk in the Innospection documentation system.



---

Innospection Limited (SLOFEC Engineer)

Mr M.Woolridge.





**30" P-161**

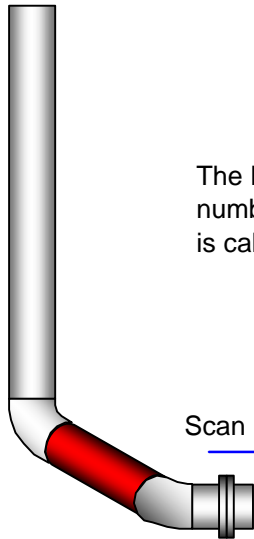

The BMP image below shows the results obtained from SLOFEC scans numbered 1 to 18 starting with track 1 on top of the horizontal section, this is called the 12 o'clock position.

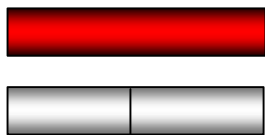

Inspected Section  
Circumferential Weld

Signal Y-component / angle analysis window set for indication of internal defects with approx. depth information

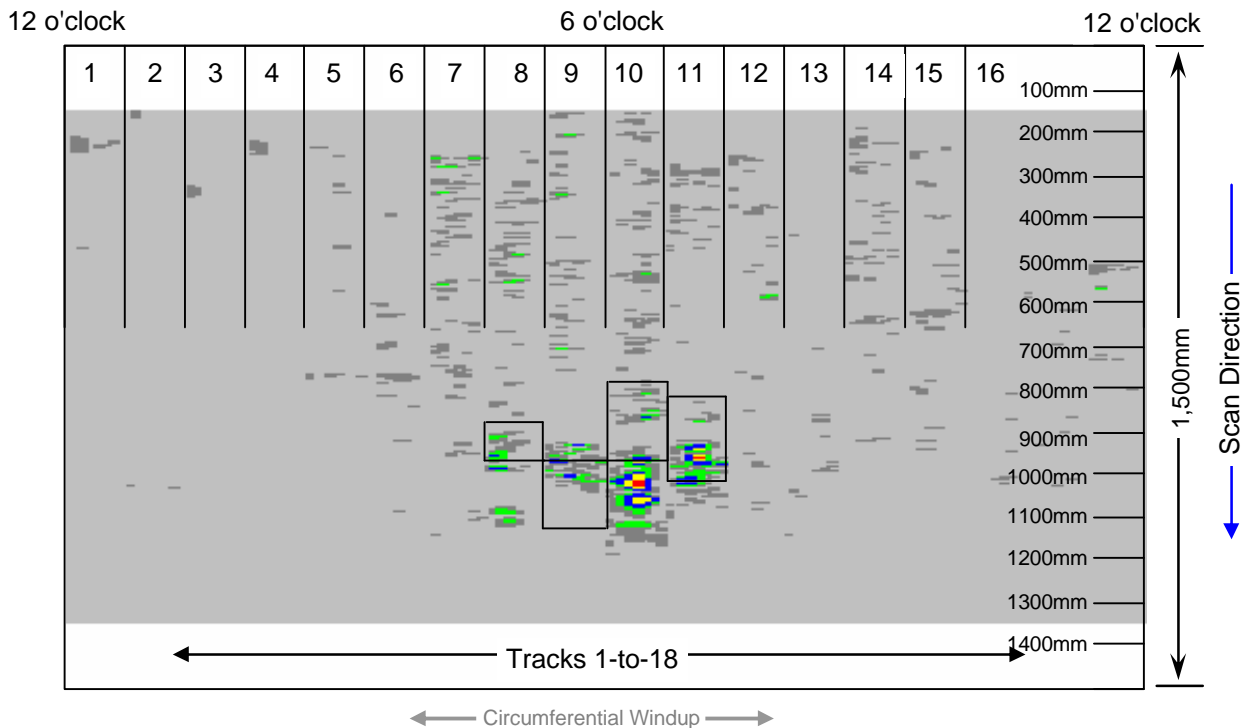
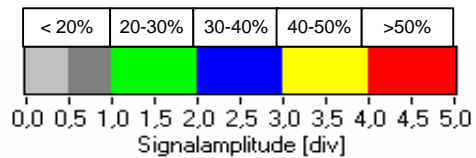

**Remarks**

The BMP images are a representation of the area accessible by the SLOFEC™ scanner. The images also show (if any) the presence of internal indications proportional in depth to the colour chart above.

Client	:	Shell Expro
Location	:	Brent Charlie
Pipe Ident	:	P-161
Pipe Diameter	:	30"
Date	:	15/11/2007
K-No.	:	434-07



Client : Shell Expro  
 Location : Brent Charlie  
 Pipe Ident : P-161  
 Pipe Diameter : 30"  
 Date : 18/11/2007  
 K-No. : 434-07



**30" P-161**

**Remarks**

The BMP images below are the result of areas found with UT, marked up and scanned with SLOFEC.

Signal Y-component / angle analysis window set for indication of internal defects with approx. depth information

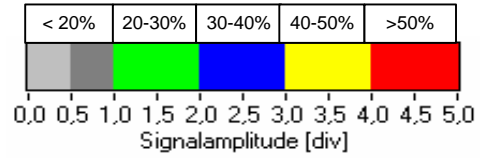

Scan Direction →

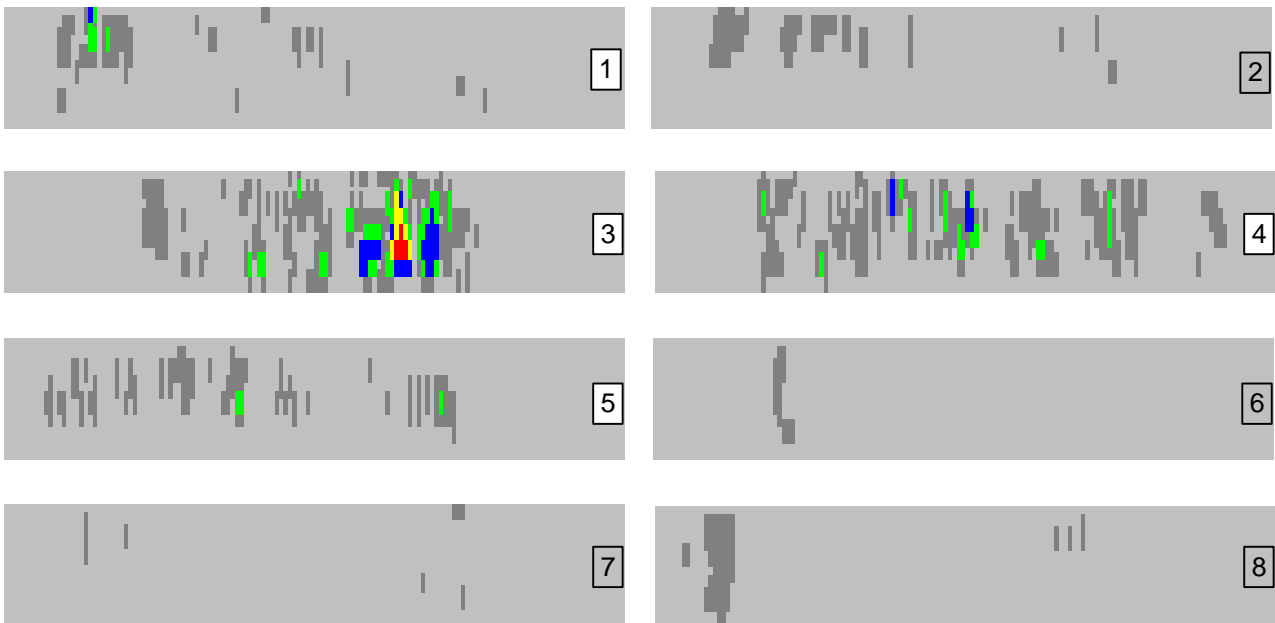

Track No's	Indication No's	UT Results	SLOFEC Results	SLOFEC % indicates the most severe indication of each scan.
1	1		20%	
2	2, 3		15%	
3	5		50 - 60%	
4	6, 7, 8		30 - 40%	
5	9, 10, 11, 12		15 - 20%	
6	13		5%	
7	14, 15, 16		5%	
8	17		5%	

UT Indication Number 4 is 50mm from the circumferential weld so has no SLOFEC scan.



**30" P-163**

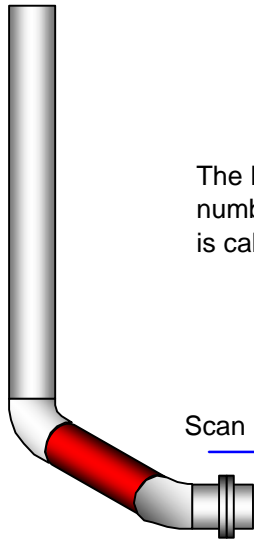

The BMP image below shows the results obtained from SLOFEC scans numbered 1 to 18 starting with track 1 on top of the horizontal section, this is called the 12 o'clock position.

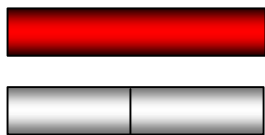

Inspected Section  
Circumferential Weld

Signal Y-component / angle analysis window set for indication of internal defects with approx. depth information

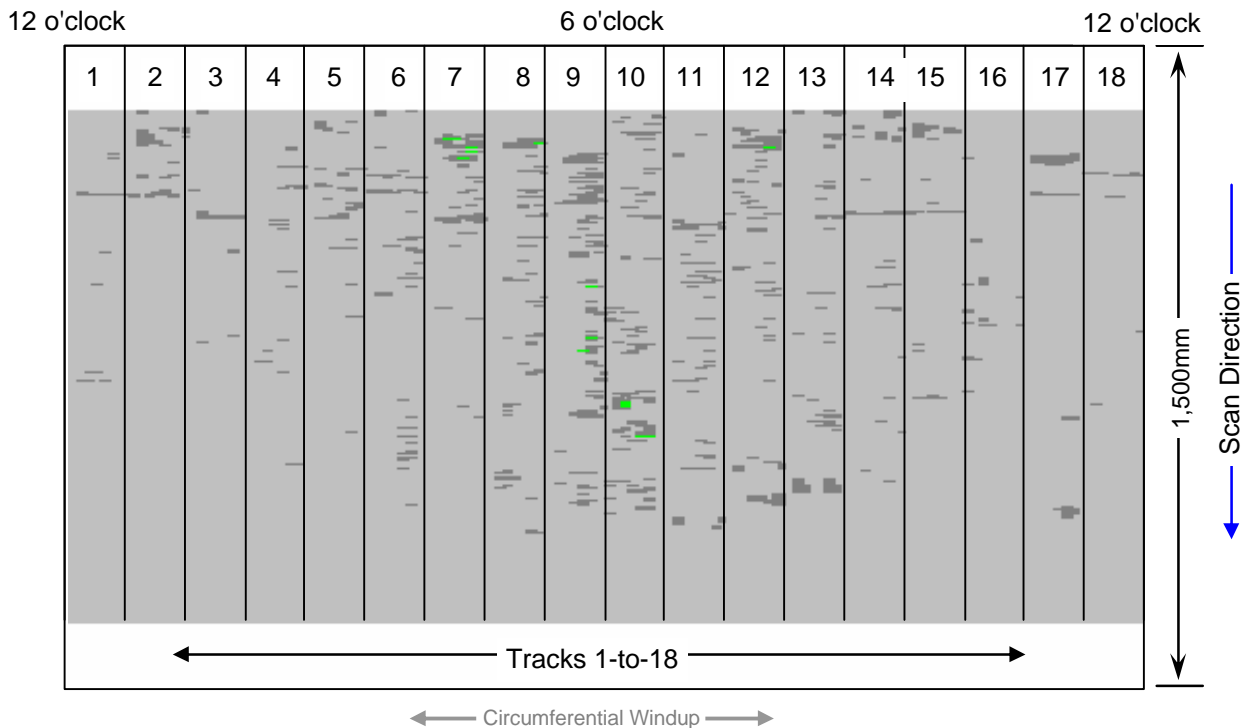
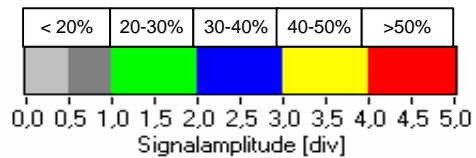

**Remarks**

The BMP images are a representation of the area accessible by the SLOFEC™ scanner. The images also show (if any) the presence of internal indications proportional in depth to the colour chart above.

Client	:	Shell Expro
Location	:	Brent Charlie
Pipe Ident	:	P-163
Pipe Diameter	:	30"
Date	:	15/11/2007
K-No.	:	434-07

Client	: Shell Expro
Location	: Brent Charlie
Pipe Identif.	: 30" Carbon Steel Pipe
Location	: Column C4
Date	: 17/11/2007
K-No.	: 434-07
	:

Signal from a set of 4mm diameter through wall holes.



Signal from a 10mm diameter 80% deep internal flat bottom hole.

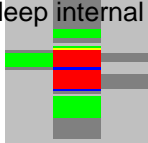

Signal from a 15mm diameter 80% deep internal flat bottom hole.

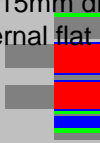

Signal from a 10mm diameter 60% deep internal flat bottom hole.



Signal from a 15mm diameter 60% deep internal flat bottom hole.



Signal from a 10mm diameter 40% deep internal flat bottom hole.



Signal from a 15mm diameter 40% deep internal flat bottom hole.



Signal from a 10mm diameter 20% deep internal flat bottom hole.



Signal from a 15mm diameter 20% deep internal flat bottom hole.



Signal Y-component / angle analysis window set for indication of internal defects with approx. depth information

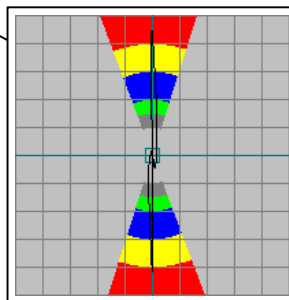
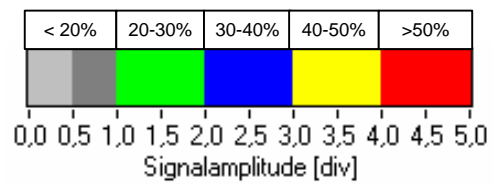

Signal from a 10mm diameter 60% deep internal flat bottom hole.

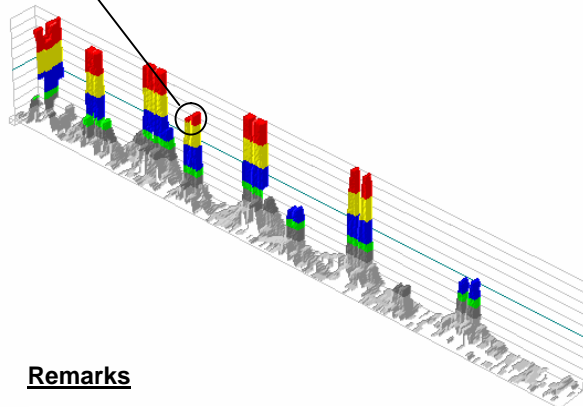

**Remarks**

This image shows the three dimensional mapping of the 10mm wall thickness test plate used for reference and evaluation.

**Note:**

SLOFEC is in principle a fast screening method for the detection of internal corrosion and pitting. It's accuracy in assessing the depth of a single indication is in comparison with the dimensions of the defect within the test sample.